

# A PROACTIVE APPROACH TO MAINTENANCE AND SPARE PARTS PLANNING FOR MARINE MECHANICAL SYSTEMS

---

**Stazić, Ladislav**

**Doctoral thesis / Disertacija**

**2024**

*Degree Grantor / Ustanova koja je dodijelila akademski / stručni stupanj:* **University of Split, Faculty of Maritime Studies / Sveučilište u Splitu, Pomorski fakultet**

*Permanent link / Trajna poveznica:* <https://um.nsk.hr/um:nbn:hr:164:586472>

*Rights / Prava:* [In copyright](#)/[Zaštićeno autorskim pravom.](#)

*Download date / Datum preuzimanja:* **2025-03-12**

*Repository / Repozitorij:*

[Repository - Faculty of Maritime Studies - Split -  
Repository - Faculty of Maritime Studies Split for  
permanent storage and preservation of digital  
resources of the institution](#)





FACULTY OF MARITIME STUDIES

Ladislav Stazić

**A PROACTIVE APPROACH TO MAINTENANCE  
AND SPARE PARTS PLANNING FOR MARINE  
MECHANICAL SYSTEMS**

DOCTORAL THESIS

Split, 2024



FACULTY OF MARITIME STUDIES

Ladislav Stazić

**A PROACTIVE APPROACH TO MAINTENANCE AND  
SPARE PARTS PLANNING FOR MARINE  
MECHANICAL SYSTEMS**

DOCTORAL THESIS

Supervisors:  
Full Prof. Nikola Račić, Ph.D.  
Full Prof. Tatjana Stanivuk, Ph.D.

Split, 2024

## **IMPRESUM/BIBLIOGRAPHICAL DATA**

The doctoral thesis is submitted to the University of Split, Faculty of Maritime Studies in fulfilment of the requirements for the degree of Doctor of Philosophy.

Supervisor: Full Prof. Nikola Račić, Ph.D.,  
University of Split, Faculty of Maritime Studies, Croatia  
Co-supervisor: Full Prof. Tatjana Stanivuk, Ph.D.,  
University of Split, Faculty of Maritime Studies, Croatia

The doctoral thesis consists of: 162 pages, including Literature, Lists and Attachments.

Doctoral thesis no.: 5

This Ph.D. thesis was prepared at the Department of Marine Engineering of the Faculty of Maritime Studies.

## **DATA ON EVALUATION AND DEFENSE OF THE DISSERTATION**

Doctoral dissertation evaluation committee:

1. Asst. Prof. Đorđe Dobrota, Ph.D., University of Split, Faculty of Maritime Studies, Faculty of Maritime Studies in Split.
2. Full Prof. Peter Vidmar, Ph.D., University of Ljubljana, Faculty of Maritime Studies and Transport, Portorož, Slovenia.
3. Full Prof. Mate Jurjević, Ph.D., University of Dubrovnik, Dubrovnik, Croatia.

Doctoral Dissertation Defence Committee:

1. Asst. Prof. Đorđe Dobrota, Ph.D., University of Split, Faculty of Maritime Studies, Faculty of Maritime Studies in Split.
2. Full Prof. Peter Vidmar, Ph.D., University of Ljubljana, Faculty of Maritime Studies and Transport, Portorož, Slovenia.
3. Full Prof. Mate Jurjević, Ph.D., University of Dubrovnik, Dubrovnik, Croatia.

Dissertation defended on: April, 25<sup>th</sup>, 2024

## **SUPERVISOR BIOGRAPHY**

Prof. Nikola Račić, PhD, obtained his BSc and MSc degrees in Marine Engineering at the Faculty of Maritime Studies in Split. He later completed his PhD degree at the University of Rijeka - Faculty of Engineering in 2008. He is a full professor/scientific advisor in a permanent position in the Department of Marine Engineering at the Faculty of Maritime Studies, University of Split. At the Faculty, he has held almost all leadership positions at all levels, from Head of Studies, Head of Department and Director of the Centre to Vice Dean and Dean for two mandates. He is currently the Head of the Department of Marine Engineering at the Faculty of Maritime Studies, University of Split.

He is the head of the following courses: Marine Engines, Marine Energy Systems, Marine Steam Generators and Heat Turbines, Marine Engineering Machinery Complex and Modelling and Simulation of Ship Systems. His research interests include numerical analysis of operating parameters of heat engines, marine energy systems and especially slow-speed diesel engines, for which he has developed a number of mathematical models and their numerical solutions. He is the author of 71 scientific and professional papers, many of which are in international peer-reviewed journals indexed in the Web of Science (CC, SCIE, ESCI).

## **CO-SUPERVISOR BIOGRAPHY**

Prof. Tatjana Stanivuk, PhD, is a graduate of the School of Natural Sciences and Mathematics in Split. In 2012 she obtained her PhD from the University of Split, Faculty of Economics, Business and Tourism. She works at the University of Split - Faculty of Maritime Studies as a full professor/scientific advisor, where she is the head of all mathematics courses, namely Mathematics 1, Mathematics 2, Mathematics 3, Applied Mathematics and Operational Research.

Her research interests are in the area of operational research in traffic and transportation technology, especially in the application of quantitative and numerical methods in modelling, optimization and simulation, with a focus on maritime traffic and shipping.

She is the author of 96 scientific and professional papers, many of which have been published in international peer-reviewed journals indexed in the Web of Science (CC, SCIE, ESCI).

## ACKNOWLEDGMENTS

I would like to thank several people who have supported me in my life and in my work on this dissertation. First of all, I would like to express my eternal gratitude to my parents, who have always been (and still are) by my side, even if only in my thoughts and actions. My special thanks go to my family and especially to my wife Tatjana for her help, support, patience and sacrifice throughout the years, first when I was at sea and later when I was away again (with books), even when I was at home. I hope that after this step in my life, I will sail into a calmer and more serene harbour. I would also like to thank my children and the rest of the family for their support and understanding of my long journey in education.

I would like to thank my initial mentor and guide, Prof. Ivan Komar, Ph.D., who has overseen all my activities since my arrival at the Faculty of Maritime Sciences and has been (and still is) a great help and support to me in this task. I would also like to thank my supervisor Prof. Nikola Račić, Ph.D., and my co-supervisor Prof. Tatjana Stanivuk, Ph.D., for their support and encouragements during this work.

I would like to thank many people who researched and analysed various articles with me and influenced my research in general. There are too many people and I will not attempt to list them all for fear of overlooking someone.

I would also like to thank the members of the committee for evaluating and defending this thesis for their efforts and understanding, especially the committee chair for his comments and suggestions that greatly improved the thesis. I must not forget to thank my colleagues and friends for their patience in reading and reviewing the work and their useful comments.

This research and this thesis would not have been possible without the help of many people from my previous companies who knowingly or unknowingly helped me during my professional career and later in the preparation of this thesis.

## ABSTRACT

The Maintenance Concept Adjustment and Design method primarily developed primarily for the maritime industry and for ships, with the aim of analysing and modelling technical systems from a maintenance point of view. The system was developed with the aim of analysing and optimizing maintenance and spare parts requirements and minimizing life cycle costs. In this study, several changes to the method are presented in order to make it more user-friendly. The first proposed change is the modification of the failure analysis method; instead of the Weibull process, the Power Law Process is introduced. The proposed change, which will simplify the failure analysis, was subjected to several suitability tests, the first being the Akaike Information Criterion test. The test showed that the Power Law Process model fits the analysed data better than the Weibull model. Next, the applicability was tested by comparing the results obtained with the Power Law Process analysis with previously published data using the Weibull method. After establishing the validity of the proposed changes, the functionality is tested on a new maintenance and spare parts optimization model, which is an extension of the model used in the Maintenance Concept Adjustment and Design method. In addition to simplifying the process, a further simplification is sought, namely the use of the brute force method to solve the optimization of maintenance and spare parts. The verification of the optimization results was carried out using Brent's optimization method and the Limited memory Broyden-Fletcher-Goldfarb-Shanno method with Boundaries. Both methods confirmed the optimization results. Finally, the optimization results were verified using the Weibull model for failure data, which confirmed the validity of the proposal to modify the Maintenance Concept Adjustment and Design method in the failure data analysis and optimization method segment. Furthermore, this thesis deals with an additional modification of inventory policy in the maritime industry due to current laws and regulations, which has never been applied before. By introducing a safety critical spare parts minimum, a new safety barrier is created to prevent the consequences of a spare parts shortage. This new minimum is included in the optimization model and tested to see how this change affects maintenance and spare parts management. Initially, this will lead to additional costs for the company and increase the safety of the ship. Further analysis has shown that the cost of these spare parts is easily compensated by the avoidance of costs that may arise from the lack of spare parts.

**Keywords:** *Maintenance and spare parts optimization, MA-CAD method, Power Law Process, Weibull distribution, Brute force method.*



# CONTENTS

<b>1. INTRODUCTION.....</b>	<b>1</b>
<b>1.1. THE RESEARCH PURPOSE AND OBJECTIVE(S) .....</b>	<b>5</b>
<b>1.2. EXPECTED CONTRIBUTION.....</b>	<b>5</b>
<b>1.3. RESEARCH HYPOTHESIS .....</b>	<b>6</b>
<b>1.4. RESEARCH CHALLENGES AND QUESTIONS .....</b>	<b>7</b>
<b>1.5. STRUCTURE OF THE THESIS .....</b>	<b>7</b>
<b>2. RESEARCH REVIEW.....</b>	<b>11</b>
<b>2.1. RESEARCH IN THE FIELD.....</b>	<b>11</b>
<b>2.2. INVENTORY POLICY IN THE MARITIME INDUSTRY.....</b>	<b>20</b>
2.2.1. Inventory Policies .....	20
2.2.2. Safety stocks .....	22
2.2.3. The safety critical spare parts minimum.....	26
<b>3. FAILURE ANALYSIS .....</b>	<b>29</b>
<b>3.1. CURRENT METHOD .....</b>	<b>29</b>
<b>3.2. PROPOSED REPLACEMENT METHOD .....</b>	<b>38</b>
<b>3.3. POWER LAW PROCESS USE .....</b>	<b>44</b>
3.3.1. Spare parts prediction .....	45
3.3.2. Planned Maintenance schedule analysis using PLP .....	47
<b>3.4. THE ANALYSED EQUIPMENT .....</b>	<b>48</b>
<b>3.5. MODEL DESCRIPTION .....</b>	<b>50</b>
<b>3.6. OPTIMIZATION EQUATION.....</b>	<b>59</b>
<b>3.7. OPTIMIZATION METHOD .....</b>	<b>69</b>
<b>4. TEST OF THE PROPOSED CHANGES.....</b>	<b>72</b>
<b>4.1. TESTING WITH VERIFIED DATA .....</b>	<b>72</b>
4.1.1. Exhaust valves .....	72
4.1.1. Fuel injectors .....	75
4.1.2. Fuel pumps .....	77
4.1.3. Comparison of parameters.....	78
<b>4.2. SHIPS FAILURE DATA ANALYSIS .....</b>	<b>79</b>
4.2.1. Ship 1 data .....	79
4.2.2. Ship 2 data .....	80

4.2.3.	PLP parameter estimation for ship 1 .....	81
4.2.4.	PLP parameter estimation for ship 2 .....	84
4.2.5.	PLP parameters estimation for system of two ships.....	85
<b>4.3.</b>	<b>AKAIKE INFORMATION CRITERION .....</b>	<b>87</b>
4.3.1.	Ships failure data AIC <sub>c</sub> test.....	88
4.3.2.	MA-CAD failure data AIC test .....	90
<b>4.4.</b>	<b>APPLICABILITY OF THE PROPOSAL.....</b>	<b>91</b>
<b>5.</b>	<b>THE APPLICATION OF THE PLP .....</b>	<b>93</b>
<b>5.1.</b>	<b>SHIPS SPARE PARTS PREDICTION.....</b>	<b>93</b>
5.1.1.	Spare parts prediction for ship 1 .....	93
5.1.2.	Spare parts prediction for ship 2.....	94
5.1.3.	Spare parts prediction using two ships parameters.....	95
<b>5.2.</b>	<b>PLANNED MAINTENANCE SCHEDULE MODIFICATION.....</b>	<b>96</b>
<b>5.3.</b>	<b>MAINTENANCE AND SPARE PARTS OPTIMIZATION.....</b>	<b>97</b>
5.3.1.	Common values for the optimization .....	97
5.3.2.	Optimization results for ship 1 .....	98
5.3.3.	Sensitivity analysis .....	100
5.3.4.	Optimization results for ship 2 .....	103
5.3.5.	Optimization using both ships parameters.....	105
5.3.6.	Comparison of optimization results.....	106
5.3.7.	Safety critical spares impact on optimization model.....	107
<b>6.</b>	<b>VALIDATION OF THE MODEL .....</b>	<b>113</b>
<b>6.1.</b>	<b>OPTIMIZATION USING WEIBULL CALCULATION.....</b>	<b>113</b>
<b>6.2.</b>	<b>RECHECKING BRUTE FORCE METHOD RESULTS .....</b>	<b>116</b>
<b>6.3.</b>	<b>RESTRICTIONS ON BRUTE FORCE METHOD USAGE .....</b>	<b>119</b>
<b>7.</b>	<b>DISCUSSION .....</b>	<b>122</b>
<b>7.1.</b>	<b>CURRENT AND FUTURE RESEARCH.....</b>	<b>126</b>
<b>8.</b>	<b>CONCLUSION.....</b>	<b>128</b>
	<b>LITERATURE.....</b>	<b>130</b>
	<b>LIST OF FIGURES AND DIAGRAMS .....</b>	<b>149</b>
	<b>LIST OF TABLES.....</b>	<b>151</b>
	<b>LIST OF ABBREVIATIONS.....</b>	<b>152</b>

<b>LIST OF VARIABLES .....</b>	<b>154</b>
<b>BIOGRAPHY .....</b>	<b>157</b>
Papers published in journals: .....	158
Papers published in conference proceedings: .....	161

## 1. INTRODUCTION

When designing an engineering system or component, there are a number of ways to improve its reliability and safety. However, when the system or component is in operation, i.e. when it is being used, there is only one way to maintain and improve its reliability and safety, namely maintenance [1]. Any improvement in the maintenance system of a technical system or equipment has a direct impact on improving its reliability and safety. Since any maintenance requires the provision of manpower, spare parts and consumables, any change in the control and monitoring of these factors has a direct impact on the quality of maintenance or the company's finances [2, 3].

PM (Planned Maintenance), as a type of preventive maintenance, is a maintenance method that significantly increases the reliability of equipment (systems) in operation, whereby maintenance is carried out according to a predetermined maintenance schedule [4]. The first PMS (Planned Maintenance System) appeared in written form more than a hundred years ago [5]. CMMS (Computerized Maintenance Management System) [4] appeared shortly after the beginning of the mass use of computers [5]. Since then, the use of PM has become more and more widespread [6].

The planned maintenance schedule in PMS (computerized or not) consists of a description of the equipment, a description of the work to be performed, and a determination of the period and frequency of the work. After the maintenance work is completed, the maintenance report is entered into the CMMS and is an important source of data on the operation of the system or equipment during the previous period. This data can (should) be used to adjust the maintenance schedule, which increases the efficiency (ability to complete the task with minimal time, money, and effort) and effectiveness (ability to achieve the desired result) of maintenance [7] and has a significant impact on overall costs. Recording maintenance, as well as failures, their causes, and the conditions under which they occurred [8], in the CMMS becomes a normal, everyday task that promotes easier analysis of the recorded data with the goal of adjusting the maintenance plan used. According to [4], today there are more than two hundred programmes for this purpose, of which more than seventy are used in the maritime industry [5]. Using the recorded data from the CMMS system as a source of useful information is nowadays the basic method for planning and adjusting the technical maintenance.

Among the methods for planning and adapting technical maintenance systems, there is only one that has been developed specifically for ships and the maritime industry. This is the

MA-CAD (Maintenance Concept Adjustment and Design) method [9], which was developed as part of a doctoral thesis at the University of Delft. The aim of the author was to create a simple and scientifically sound method for modelling the maintenance of ship mechanical systems, taking into account the LCC (Life Cycle Costs), which can be applied in practice without major difficulties and preparations. The method has been tested in the maritime industry, i.e. on merchant ships, and its testing has clearly demonstrated its usefulness for the industry. In his dissertation, the author of the method presented, among other things, guidelines for the future development of the MA-CAD method. In Section 13.2.3.3, he states that the method should be extended to include the spare parts system, which was not included in the original method. Eleven years after the development of the method, the method was extended by A. Bukša [8], who included these capabilities, i.e. the planning and modelling of the spare parts quantity during ship operation. This added an important segment to the method, especially in the consideration and modelling of LCC. Since this update, this newer modified version of the method has been used without further updates. Although the method was developed for shipping and ships, it is applied both at sea and on land [5, 10 – 17].

This addition to the method, namely spare parts monitoring and modelling, has significantly improved the original method. Many studies have shown that poor planning of spare parts can lead to the procurement of larger quantities of unnecessary parts (and thus to financial losses) [18 – 20] or conversely to their absence, which can prolong maintenance or cause costly delays.

In the development of the original method MA-CAD method, Weibull analysis, the most widely used approach for modelling failures, was used to evaluate failures and as the basis for calculating the LCC [9]. This distribution can describe the failures of the analysed systems very well, and [8] also adopted it when he extended the MA-CAD method with a spare parts system. This approach of the Weibull method is predominant in most authors analysing spare parts systems [21], [22], [23].

When analysing the MA-CAD method for the purpose of this research, in particular the spare parts system, the possibility of further modification or extension of the spare parts system was identified. This was identified during the preliminary research for this thesis, which determined the direction and purpose of the research. The conclusion from this preliminary analysis was that it is necessary to conduct a new analysis of the spare parts process and develop additional proposals for further modification of MA-CAD based on the recommendations and observations of the two authors of the method and the experience gained through personal research.

Several areas for improvement were identified as well as the possibility of replacing the Weibull analysis with a different approach. The methodology chosen to modify the MA-CAD method is PLP (Power Law Process), one of the established methods for failure time analysis of repairable systems, which is known for the simplicity of statistical inference procedures [24]. Another important property of PLP is emphasised in the same article: "*If the reliability of the system does not change after repair, that is, the repaired system is in the same state after repair as immediately before the failure, then the appropriate model is NHPP*" [24] (Non-Homogeneous Poisson Process).

Most of the equipment on board ships is repairable when considered on a larger scale. The repairs carried out are usually minimal repairs that restore the component (unit) to the state it was in before the failure. This minimal repair (the so-called "same as old" [24]) is also one of the characteristics of repairs on board ships. These reasons are the basis for the choice of PLP as the method of analysis in this thesis.

Another reason for choosing the PLP method is the simplicity of the statistical inference procedures. This feature could contribute to the increased use of MA-CAD in a very conservative and passive environment such as the maritime industry [25, 26], which is very resistant to the introduction of changes.

PLP is used in this case in failure time analysis of analysed system samples based on data from maintenance records. The collection of maintenance data and the use of this data was briefly commented on in the original MA-CAD method in Section 11. At that time, the author of the method did not mention the use of CMMS (the use of CMMS was increasing at that time, but was not yet up to date), which are now the most common source of data for shipboard maintenance. In this thesis, this data is used as ADI (Advanced Demand Information) and analysed with PLP.

There are several different solutions for applying the failure data analysis presented in this thesis. In the first part of the calculation, the data estimate is used to predict the amount of spare parts needed in a given time period, assuming that the crew does not want to change the maintenance schedule. In the second part, the same estimate is used to calculate the optimal maintenance schedule to adjust the maintenance to the desired reliability. In the third part, the same data is used as a basis for calculating the maintenance costs and their optimization, as well as for calculating the economic quantity of spare parts on board.

Nowadays, there are many different optimization methods, the most popular methods in the engineering field include Sequential Linear Programming (SLP) [27, 28], the Sequential

Quadratic Programming (SQP) algorithm [29, 30], the Brent's method [31, 32] and the Limited memory Broyden–Fletcher–Goldfarb–Shanno (L-BFGS-B) method with boundaries [33, 34].

The BFM, as the simplest method for solving relatively simple mathematical problems, is used in this thesis to solve the optimization Equation. This approach is a continuation of the simplified approach previously used for failure analysis. The BFM can be described as a method in which the problem is solved by exhaustion, i.e. the method searches for all possible solutions and finally selects the most favourable solution if it exists. This method requires considerable computing power and was not applicable until recently due to insufficient computer capacity [35, 36]. Today, with the advancement of computers, this approach can be used for simpler examples with a small number of optimization parameters and with limited range [37, 38]. Since the studied example fulfils the above conditions, this method is the first choice.

Another question that needs to be answered is the determination of the programming language in which the method is to be defined. The Python programming language [39] has established itself as a cost effective and relatively simple solution for creating the optimization programme. Python is a general-purpose programming language that can be used for a variety of applications and is very popular in the programming community. It is freely usable and distributable, even for commercial purposes [39].

Testing the applicability of the proposed changes is performed in two steps. This is achieved by applying the model selection criterion [40, 41] to compare Weibull and PLP and determine which statistical model is more suitable for the analysed dataset. In this case, the Akaike model criterion [40] is used.

Next, the applicability of the proposed changes is evaluated by importing failure data [8] and calculating the recommended spare part quantity and maintenance interval using the PLP method and comparing the results.

The validity of the results is checked in several ways. First, alternative methods are used to solve the optimization equation and the results obtained with the BFM are confirmed. In this case, the results are verified using the Brent's method [31, 32] and the L-BFGS-B method [33, 34].

## **1.1. THE RESEARCH PURPOSE AND OBJECTIVE(S)**

The purpose of this research is to modify and improve MA-CAD method in the area of failure analysis and to renew and extend the maintenance and spare parts planning system within the framework of the MA-CAD method based on the findings of the preliminary research, so that the system becomes even simpler and more practical. The research purpose is also the main objective of the research. This overall objective is divided into several steps:

- Analysis of the use of CMMS data for potential benefits in the process of maintenance management, work force management, and spare parts management.
- Modification of the ordering policy for the minimum quantity of spare parts in the MA-CAD model by adding additional safety features according to existing regulations and recommendations.
- Creation of a very simple spare parts consumption prediction system using PLP method suitable for ship's crew (with limited computational resources).
- Introduction of the above defined features into the spare parts planning model inside MA-CAD and redefinition of the model based on the new results.
- Redefining the determination of EOQ (Economic Order Quantity) inside MA-CAD by introducing new limits for the minimum quantity of spare parts and a new spare parts planning system.
- Introduction of a new spare parts and maintenance optimization model to complement the method.
- Application of a model selection criterion, Akaike Information Criterion (AIC) in this case, to compare the two approaches, Weibull and PLP, to determine the more appropriate solution.
- Creation of a simple computer-aided optimization program using the BFM and the Python programming language.

## **1.2. EXPECTED CONTRIBUTION**

The expected contribution is closely related to the purpose of this research and its objectives by demonstrating the proper use of CMMS data that allows to take full advantage of all the benefits that the data can provide. This use is closely related to the intention of modifying the MA-CAD method and incorporating rules that currently exist for determining the minimum quantity of spare parts on the ship into the optimization model.



Summarizing all the above facts, it can be concluded that the expected contributions are closely related to the research objectives. These are:

- Demonstration of the use of CMMS data for potential benefits in the process of maintenance management, work force management, and spare parts management.
- Modification of the MA-CAD method in the part of failure analysis by replacing Weibull with PLP for modelling failure data.
- Creation of a new approach for the minimum quantity of spare parts in the model.
- Development of a methodology for predicting spare parts consumption for corrective maintenance to complement the MA-CAD method.
- Creation of a new spare parts planning model for MA-CAD, which will be an extension of the current model.
- Development of a substitute calculation methodology to determine EOQ that increases the number of influencing parameters and provides an additional level of safety.
- Modification of a spare parts and maintenance cost model.
- Simplification of the optimization process using the BFM.

### 1.3. RESEARCH HYPOTHESIS

The hypothesis is derived from the research purpose and is fully formulated when the research objectives are established. The hypothesis is formulated:

**The proposed changes to the MA-CAD method, using power law process and brute force to solve the optimization, expand the capabilities and provide a simplified and better solution for the spare parts and maintenance management system.**

There is a second, non-formal hypothesis that is even more important to maritime users than the formal one. It was confirmed in the preliminary analysis and during the course of the research:

**Readily available data from the CMMS system can (should) be used as a data source for predicting and modelling spare parts, maintenance, and work force management.**

#### **1.4. RESEARCH CHALLENGES AND QUESTIONS**

Re-examination of the results obtained required the assistance of the shipping companies in extracting the data from their CMMS. Getting their cooperation and willingness proved to be the first real challenge. According to Det Norske Veritas & Germanischer Lloyd (DNV-GL) Chief Executive Officer (CEO) Henrik O. Madsen, the maritime industry is “*too conservative and too passive*” [25], and this opinion is confirmed by other sources such as [26]. At the same time, it is known for being very secretive and trying to hide business knowledge and working principles. It was very difficult to find a company willing to allow the research team to see their data and use it later; more than one company simply refused any access.

All other problems encountered during the research were minor in comparison to this problem. These minor challenges during the research were determining the method for predicting spare parts demand and incorporating this prediction into the new spare parts planning model for MA-CAD, and creating an appropriate spare parts and maintenance optimization model to be integrated into the MA-CAD method. The requirements for the model are extensive: it should be simple enough to be applied by the ship's crew, provide accurate results to avoid misjudgements, and at the same time be suitable for maintenance and spare parts optimization. PLP fully met these requirements and was selected for the failure time analysis of the selected data.

Another minor challenge was determining the method to be used to solve the optimization and the mode in which that method would be created. The combination of the BFM written in the Python programming language met all the requirements set for PLP, and another was that the method had to be free.

#### **1.5. STRUCTURE OF THE THESIS**

The thesis is based on the common goal of proposing ways to improve the MA-CAD method by adding some new features and modifying some of the existing ones.

In the introduction, the first Chapter, the historical background of the topic of the thesis is presented, followed by a definition of the research purpose, the expected contribution and the hypothesis. At the end of the first Chapter, the research challenges and the form of the thesis are presented.

The second Chapter provides a research overview of the developments in the field of maintenance and spare parts management. At the end of the chapter, part of the preliminary research is presented, which deals with a specific problem, namely the difference between

inventory policies in the land-based industry and in the maritime industry. An overview of the existing inventory policies (onshore and in the maritime industry) is given, followed by an overview of the safety stock and its purpose. The safety critical spare parts as an important part of this research and novelty in the inventory policy are presented at the end in the form of a conclusion and as an introduction for further analysis presented later in the thesis.

The failure analysis and the description of the problem are described in the third Chapter. The Chapter begins with an overview of the Weibull method, which is currently used in MA-CAD as a tool for failure analysis, with a part dealing with the estimation of the Weibull Maximum Likelihood Estimate (MLE) and the problems associated with this procedure. At the end of this section, the issue of sample size, an important problem in failure analysis, is addressed, explaining the problems with confidence intervals in Weibull analysis.

It continues with a description of the PLP, the method proposed to replace Weibull in MA-CAD. After the description of the PLP method, a section of a Chapter is dedicated to the presentation of the estimation of the MLEs in the PLP, explaining where the simplification lies in the estimation process. This section also ends with the question of sample size and explains the problems with confidence intervals in PLP.

This is followed by an explanation of how and where the PLP method is used, presenting two different areas, namely the prediction of spare parts consumption for corrective maintenance and the prediction of the planned maintenance schedule. This is followed by a description of the equipment that is analysed in this thesis, i.e. that serves as an example for testing the proposed changes. This is followed by the development of the two-parameter optimization Equation, with a detailed description of the procedure. It is linked to the BFM, an optimization method used to solve the Equation. At the end of this chapter, a brief description of the Python computer program (used to code the BFM optimization) is given.

Once a proposal has been drawn up and the method(s) by which this proposal is to be put into practice have been determined, it must be checked whether this idea is applicable, i.e. whether it is possible to put this idea into practice. The review itself is described in Chapter four.

In the first part of the Chapter, the data from [8] were used and the calculation of spare parts required for corrective maintenance and the recommended interval of planned maintenance was carried out using the PLP method. The calculated data is then compared with the results obtained [8] with the Weibull method to confirm that the results obtained with the PLP method are OK. This was done with all three data sets.

The next part of the chapter contains data on the research subjects, the recorded failures and the maintenance plan. This is followed by the estimations of the PLP MLEs which will be used throughout the study. The PLP MLEs are estimated for each of the two ships separately and for both ships together, which is another aspect of the PLP method. This method allows the estimation of common parameters for sister ships, which makes it possible to increase the sample size and reduce the problem of small sample size.

The last part of Chapter four is dedicated to information criterion analysis to determine which distribution is a better fitting model for the analysed data set. This is done using the AIC (Akaike Information Criterion) for the data example from MA-CAD and the AIC<sub>c</sub> (Akaike Information Criterion second order for small samples) for the data used in this thesis.

The application of the PLP method is shown in the fifth Chapter, in which first the required spare parts for ship 1 and then for ship 2 are calculated, as well as with estimated parameters for both ships together. This is followed by the actual calculation of the planned maintenance schedule. These one-parameter optimizations are followed by a two-parameter optimization problem, in which the optimization of the maintenance and spare parts costs for ship 1 and ship 2 is solved and additionally using the parameters estimated for both ships.

After optimising the maintenance and spare parts costs for ship 1, a sensitivity analysis is carried out as part of the verification and validation process. The sensitivity analysis is presented in two aspects by varying the deterioration of the equipment and inserting corrected parameters for upper and lower confidence limits.

The effects of the safety critical spare parts minimum on the new optimization model, i.e. on the total cost for maintenance and spare parts, are analysed individually for each ship at the end of this Chapter in order to check the overall behaviour of the model under these conditions.

The process of checking and validating the changes described above is described in Chapter six. The validity of the results of the BFM as the chosen method is verified at the beginning of this Chapter by solving the main optimization equation using two other scientifically proven methods, namely the Brent's method and the L-BFGS-B method. The results obtained with these two methods confirm beyond doubt that the results of BFM are correct. The next (and final) step in the verification and validation process is the calculation of the optimization Equation using the Weibull method, which is presented in the second section of this Chapter. The obtained results are compared with the optimization results calculated using the PLP method in order to make a final assessment of the applicability of the PLP method in the studied examples.

The discussion is presented in the seventh Chapter. The first section deals with the use of CMMS in the shipping industry and contains a brief description of various aspects of CMMS use (or non-use). It is followed with highlights of testing behaviour of the optimization model under different conditions. Work in progress related to this thesis is added to this chapter, namely the development of a DSS (Decision Support System) to help CMMS users analyse failure data without much effort. The last part of the chapter contains ideas for future topics and research.

In the Conclusion, all aspects of this thesis are presented, followed by a bibliography, a list of figures, tables, etc. and several attachments.

## **2. RESEARCH REVIEW**

Numerous scientific and technical papers have been published in the literature describing the various aspects covered in this thesis, in particular the various aspects of maintenance adjustments and analysis as well as spare parts management and the analysis of CMMS as a data source for adjustments. This review lists the papers that are relevant to the presentation of previous achievements in this area, as well as the work that has influenced the preparation of the thesis in various ways.

The overview consists of two parts. The first part describes previous research in this area, while the second part presents some of the preliminary work that laid the groundwork for this optimization equation.

### **2.1. RESEARCH IN THE FIELD**

A structured approach to improving ship maintenance was described long ago by Beyers, who said that maintenance data (he called it history data) should be analysed to "*evaluate the adequacy of existing maintenance policy for selected systems or equipment and recommend changes to existing maintenance policy or equipment design, including replacement*" [42].

Research in the field of maintenance started a long time ago, some articles on this topic were published in the beginning of the 20<sup>th</sup> century [43]. While the first researches established the basic principles of maintenance, further researches in the middle of the 20<sup>th</sup> century became more complex and detailed and dealt with the optimization of maintenance and resources. Planned maintenance as a subfield of preventive maintenance appeared in the literature relatively late, with the first documented research dating back to the 1940s [44]. In the 1950s and 1960s, research on planned maintenance developed slowly until numerous studies on planned maintenance appeared in the 1970s.

CMMS research began very soon after the development of widely available computers and programs [6, 45]. CMMS research in the marine industry also began early and continues to this day [46 – 48]. Despite the fact that changes in the system and its data affect the maintenance process, the actual study of CMMS and its aspects has not attracted much interest from researchers due to the limited number of published articles on the benefits of its use and possible improvements [49, 50].

In a preliminary research, the use of CMMS data in segments of shipping operations was analysed and it was shown that the data can (should) be used in the areas shown in Figure 1. These areas are maintenance management, inventory (spare parts) management, work force management, and purchasing management.

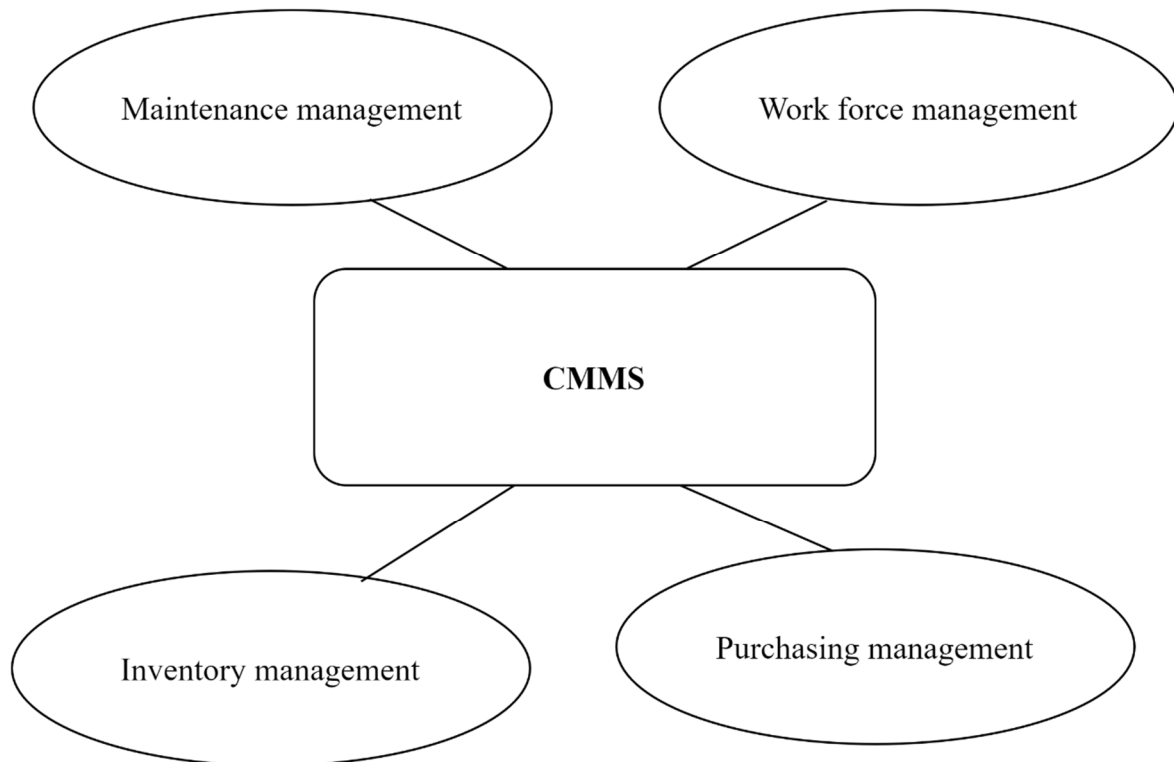
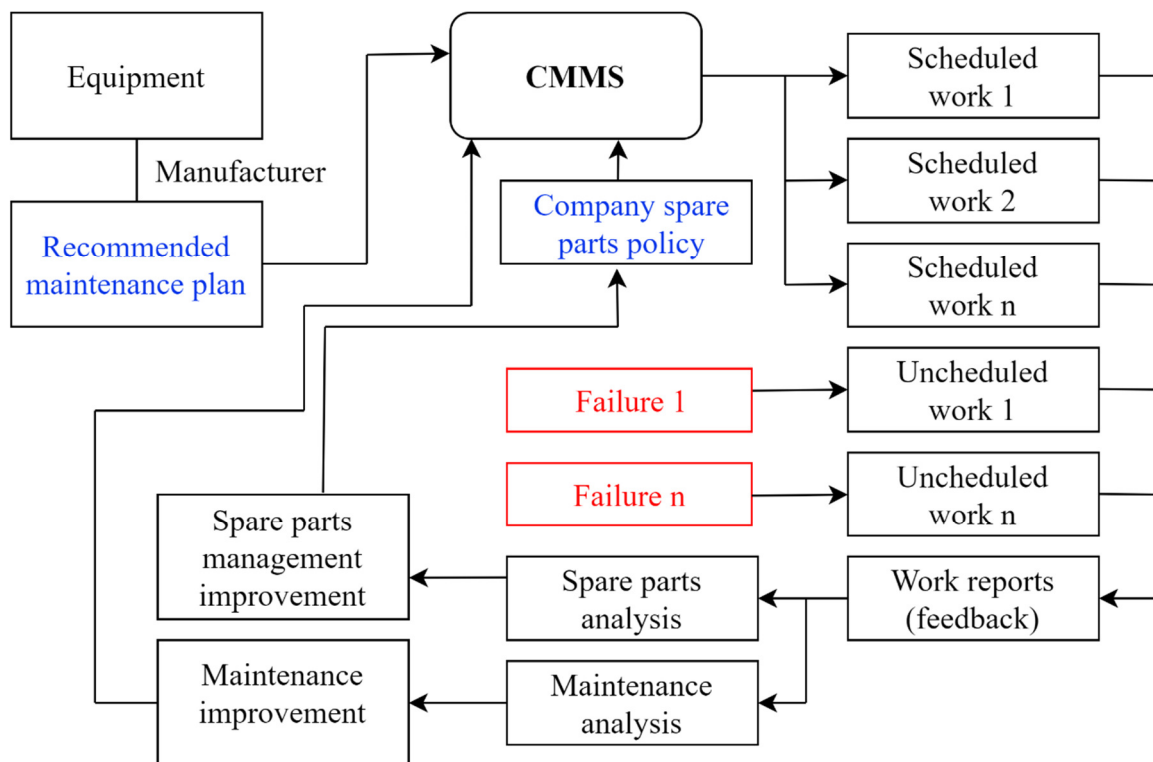

**Figure 1. CMMS areas for improvement**

For each of the segments shown in Figure 1., research was conducted into how the data could be used in practice and articles were then published. Maintenance management was the main topic in articles [5, 16, 17], work force management was analysed in article [51], inventory (spare parts) management was studied in [20], while purchasing and supply management was analysed in [52].

The re-examination of the CMMS and its data for the preliminary research revealed a problem that Hu et al. [53] had also encountered in their study. The problem is that several investigated companies showed complete ignorance in using the data collected in the CMMS, i.e. in several investigated companies there was neither an established working practice (Figure 2.) for reporting back equipment failures nor for analysing the data and taking advantage of the resulting benefits.

Figure 2. describes the missing link in working practice and shows an example of using the data collected in the CMMS to improve maintenance and spare parts management. The initial CMMS is created for each piece of equipment based on the manufacturer's recommended maintenance schedule, while the spare parts quantity for the ship is determined based on the company's spare parts policy. The work orders planned in the CMMS are carried out regularly, as is the corrective work following identified failures and deficiencies. Once the maintenance work has been completed, work reports or maintenance logs are entered into the system, recording all the necessary maintenance data and the spare parts used. By analysing maintenance activities and spare parts consumption, it is possible (and necessary) to modify the maintenance plan and spare parts management (proactive approach).



**Figure 2. The analysis of the work reports (feedback)**

Over time, the number of maintenance records will increase and the CMMS data will become more reliable and individualized for each machine system. It is important to note that Figure 2. illustrates maintenance and spare parts management based on CMMS data; work force management can be monitored and managed in the same way.

Research in the field of maintenance and spare parts management deals with a variety of different topics, looking at different problems from different angles, such as spare parts



ordering principles [53, 54], spare parts delivery [52, 55], spare parts management from different [56, 57], spare parts cost modelling [58, 59], minimizing carbon footprint [60, 61], and similar topics.

Recently, Mouschoutzi and Ponis presented a systematic literature review on the supply chain and logistics management of ship spare parts [62], which includes most of the relevant literature in this area.

Authors such as Vandeput [63], Trimp et al. [64], Axsäter [65] and Jardine and Tsang [66] identified key characteristic inventory levels in their work and confirmed that spare parts quantity is best determined by spare parts forecasting, a process that can be based on historical data, advance demand information (ADI) or a combination of both [3, 19, 56]. ADI of future spare parts demand can be derived from various sources such as machine operating data, shore service schedules, etc., and can be categorized into two subgroups: perfect and imperfect ADI.

Perfect ADI is much simpler for spare parts forecasting as it assumes that accurate information is available on the demand for spare parts, indicating exact quantities and due dates when these parts will be needed [67]. With imperfect ADI, quantities and/or due dates may change over time, and a spare part order may even be cancelled [67]. The literature in this area follows this classification.

Boudrika in her study [68] evaluated the benefits of using perfect ADI; Nataraja and Atan [69] evaluated the benefits of perfect information for allocation policy in a serial inventory system. Basten and Ryan [70] investigated the use of perfect ADI to create flexibility for maintenance delays in an improved spare parts inventory management system. Imperfect ADI has been researched much more than perfect ADI in recent years. Tan et al. [71] studied the optimization of ordering policy, where the ordering level is a function of imperfect ADI. A similar approach is used by Zhu et al. [19], where the authors use condition-based maintenance as a source of ADI. This approach is also used by Lin et al. [72] and Ahmadi et al. [73]. Some authors such as Chen [74] used both ADI in their models to compare the results.

Although planned maintenance has been used as a source of ADI in many different studies [3, 19, 70, 75], a clear link to CMMS (or ERP - Enterprise Resource Planning) data is not often mentioned [69, 76].

The criticality of spare parts is another area of research, both in the maritime and onshore sectors. Antosz and Ratnayake [77] analysed the evaluation of spare parts criticality and its prioritization to improve the availability and reliability of manufacturing systems, Gajpal et. al. [78] analysed the hierarchy process using VED (Vital, Essential, Desirable) classification to measure the criticality of spare parts.

The storage of spare parts is another problem as they are subject to the effects of deterioration [79], which depend on the local storage conditions (on ships they are usually unfavourable due to the marine environment) and the total duration of storage. The quantity of spare parts is also a problem, because in a complex system such as a ship there are a large number of spare parts, which can be very expensive and therefore costly to purchase and, above all, to store.

The financial resources associated with storage are enormous, sometimes up to a third of the value of the company's total assets [80]. Large financial amounts, the need for ship safety, difficulties in procuring and delivering spare parts to the ship, the deterioration of spare parts on the shelf and many other factors pose real challenges for spare parts management and planning.

It has been proven that an adequate amount of spare parts is required to organize successful maintenance and that spare parts are consumed during maintenance activities, i.e. spare parts management is affected by preventive maintenance (planned maintenance) and by random failures of equipment in service [19, 81].

Cavalieri et al. [76] proposed a multi-step decision making framework for spare parts management, shown in Figure 3., and pointed out that not many companies use this approach.

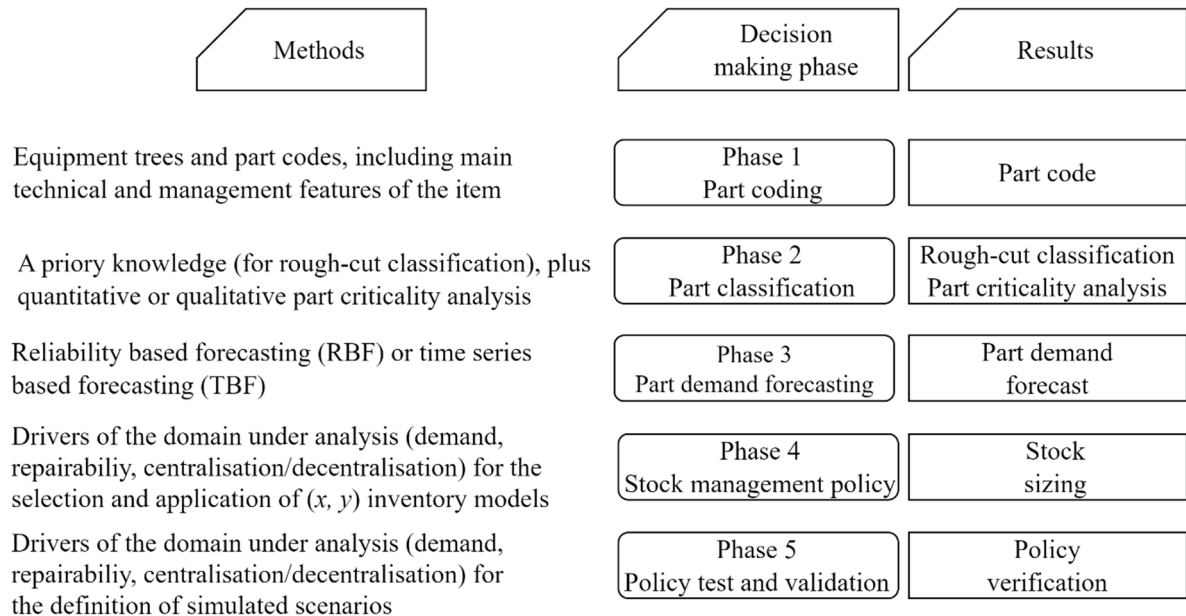

**Figure 3. Decision-making steps [76]**

A similar opinion on the inappropriate use of various models developed for maintenance (and spare parts) management was expressed by Dekker, who said that “*maintenance optimization models are difficult to understand and to interpret*” [82].

Cavalieri et al. [76] also used CMMS (or ERP) as a source of ADI for spare parts consumption in their study and relied on data from the system to forecast consumption. In their study, they used the term MRO (Maintenance, Repair, Operations) for all maintenance activities. This term is widely used in various shore-based industries and sometimes in naval maintenance, while it does not occur in the civil maritime industry. Although they did not create optimization models, this research has several connections to this current research. Both use CMMS as a data source, both emphasise the importance of good data in the system, and both researches concluded that the actual application of an active approach is largely lacking in the industry studied.

It has already been mentioned that the maritime industry is conservative and passive [25, 26]. Considering the conservative mindset and the difficulty of understanding and interpreting optimization models, it can be assumed that spare parts management in the maritime industry is fully in line with Cavalieri et al. assertion [76]. The above assertion is supported by the fact that there are very little papers analysing the quantities of spare parts on board ships and their usefulness [20, 62, 83].

The safety stock is a quantity of spare parts kept in storage to prevent an out-of-stock situation. This quantity serves as insurance against fluctuations in consumption and as a bridging quantity. The safety stock or safety minimum as a characteristic stock level is also studied by several authors [62 – 65]. Jardine and Tsang [66] call this level the insurance quantity. call this level the insurance quantity. The determination of this quantity is also studied by many authors [57, 63 – 66, 70, 81, 84 – 86], and is one of the most important areas for spare parts optimization. The safety stock and other considerations for consumption fluctuations and as a bridging quantity in the maritime industry are discussed later in this thesis.

The optimization of maintenance is one of the most frequently studied topics. Dekker [82] has written a review and analysis of the applications of maintenance optimization models, a very frequently cited article. Although some time has passed since this article was published, it is still relevant in many areas and forms the starting point for many considerations. He analysed models and came to the conclusion that age [66, 87 – 91] and block replacement models [60], [92 – 95] are most commonly used, followed by Markov decision models [96] and the delay time model [97, 98]. He also analysed areas and industries where research has been conducted and found that they are equipment and vehicle replacement (buses, forklifts,

ambulances), inspection optimization, road maintenance, and electric power generation plant maintenance scheduling. A more recent literature review on maintenance optimization models, which can be seen as an extension of Dekker's research, was conducted by De Jonge and Scarf [99], who analysed the period from 2001 to 2018. Although they called the article “A review on maintenance optimization”, many common maintenance and spare parts optimization models are included in the thesis.

According to [61, 99-104], there are four different types of optimization criteria for maintenance (and spare parts):

- minimization of the cost rate,
- minimization of the total costs over a time horizon,
- maximization of the availability,
- maximization of the reliability.

De Jonge and Scarf [99] mentioned that adding spare parts to maintenance optimization complicates the process somewhat. One of the examples of joint optimization was written by Brezavšček and Hudoklin [92], who performed maintenance optimization with block replacement and periodic review of spare parts provisioning policy. A very similar optimization was performed by Van Horenbeek et al. [105], who also used a periodic review of the spare parts provisioning policy, but with age-based replacement. At the same time, they introduced a time delay when spare parts are not available.

A slightly different approach is presented by Chelbi and Ait-Kadi [106], who use a block replacement policy and a variable ordering point for spare parts. In another paper, they use a variable ordering point for spare parts and an age replacement policy [107].

Another consideration in the reviews is the nature of the maintenance actions taken in the event of a failure. Two main types of actions are distinguished: restoration to As Good As New (AGAN) condition and restoration to pre-failure condition, often referred to as As Bad As Old (ABAO) or minimal repair. In addition to these two main types of actions, there is a wide range in between, referred to as better than old or younger or imperfect maintenance [108]. Authors choose different approaches and use different combinations.

Ba [60] researched preventive maintenance and spare parts inventory where preventive maintenance consists of block type replacement [87, 88] restoring the unit to an AGAN condition, while corrective maintenance is performed as a minimal repair that returns the system to the exact condition it was in just before the failure (ABAO). In his study, he did not consider

the shortage of spare parts, but addressed this issue by stating that “*it is very hard to evaluate the shortage costs for spare parts*” [60].

Zheng et al. [109] researched the optimization of Condition Based Maintenance and spare parts ordering using a renewal process, while Zhang et al. [110] researched the optimization of preventive maintenance and inventory management. In both studies, the Preventive Maintenance (PvM) and Corrective Maintenance (CM) actions are perfect and make the units AGAN.

In contrast to the above examples, Su and Liu [111] use imperfect repairs in their study and the post-repair state is somewhere between AGAN and ABAO.

It should be noted that all the listed literature on safety stocks and optimization of maintenance and spare parts deals with problems in the shore industry. Examples analysing problems in the maritime industry are not available in some areas. Safety stocks in the maritime industry have been studied by Bukša [8], Cheaitou and Cariou [112], and recently by Pahl [84]. In all the listed articles, the safety stock is calculated in exactly the same way as in the land industry, without taking into account the specific problems of the maritime industry.

There are also few articles on the optimization of maintenance and/or spare parts in the maritime industry. Kian et al. [113] studied the spare parts management problem for maintenance scheduling without considering maintenance. Eruguz et al. [114] described an integrated maintenance and spare parts optimization problem for a single critical component of a moving asset with deterioration. Their research is applicable to all movable assets and they mentioned the maritime industry (ships) as an example of possible application of the model. [8] presented a classical maintenance and spare parts optimization problem with the intention of minimizing the LCC.

The MA-CAD (Maintenance Concept Adjustment and Design) method [9] is the only method developed specifically for ships and the maritime industry for designing and modifying technical maintenance. The method was developed as part of a doctoral thesis at the University of Delft with the aim of creating a simple and scientifically sound method for modelling the maintenance of ship technical systems, taking into account the LCC. The method was tested on merchant ships and demonstrated its applicability in industry. The method includes a complex approach to components and their failures, performing FMA (Failure Mode Analysis) to determine predictability, reviewing RI (Risk Index), investigating FMCC (Failure Mode – Cause Combination), reviewing and analysing ELFF (Expected Life Failure Frequency), ELCF (Expected Life Cycle Frequency) and ELPF (Expected Life Prevention Frequency). The

application of the above-mentioned methods to the failure data obtained from the ship's operating data represents the actual method.

The author originally mentioned only operational data without specifying how the data can (should) be collected. Considering that most ships today record all maintenance activities in various CMMS programmes, the simplest method of failure data collection is to take it directly from the system.

Failure data analysis in MA-CAD is modelled using the Weibull distribution and the MLE method [115 – 117] is recommended for parameter estimation.

During the development of the MA-CAD method, it was recommended by the author to further develop the method with the spare parts system, which was not included in the original method. This was done by A. Bukša [8], who created this functionality in MA-CAD by adding the planning and modelling of spare parts quantity during ship operation in the form of LCC.

After introducing spare parts planning and modelling, the same author created the first MA-CAD optimization model that included both maintenance and spare parts segments. The method has been used in this form since 2005 without improvements and modifications both in the maritime industry and outside it [5, 10 – 17].

The method chosen in this thesis to replace the Weibull method in the optimization and modelling of maintenance and spare parts is the PLP. The process was first introduced by Duane [118] in 1964 as a tool for effectively analysing and controlling changes in reliability over time. Crow [119 – 122] continued the analysis and development of the model and became one of the most cited authors in the field. Because of these two authors, the model is sometimes referred to as the Duane model (after its primary author) or the Army Materiel Systems Analysis Activity (AMSAA) model (after the first application shown by Crow [120]). The PLP model is often used for reliability growth [24, 121 – 123], and the best description of the model comes from Rigdon and Basu, who say that it is "*more realistic, a priori, in most situations*" [24]. Authors such as Kontrec and Panić [22] linked spare parts ordering to reliability, while Qarahasanlou et al. [124] used the PLP model for spare parts.

The optimization of maintenance and spare parts is performed using a simple method, the BFM. The BFM is the oldest and one of the simplest methods that can be applied as a solution. Due to the high computational power required for the calculations, it has long been neglected for serious applications [35, 36]. With the development of better and more powerful computers, the application of this method became possible, and recently studies using this method have appeared in scientific journals [37, 38 125, 126].

The Python programming language [39, 127, 128] is used in this thesis to code the optimization model. Python is a high-level programming language with dynamic semantics, which is one of the most widely used programming languages in the world today.

The spare parts inventory policy is an important part of any optimization model for maintenance and spare parts and has already been mentioned above. Some aspects have already been highlighted, such as the safety stock or the safety minimum [62 – 66], which have been mentioned in both the land-based industry and the maritime sector. Due to the particular importance of these topics, a part of the preliminary analysis presented in the following section is dedicated to them.

## **2.2. INVENTORY POLICY IN THE MARITIME INDUSTRY**

In the preliminary research for this thesis, more precisely in the literature review for the mentioned article [20], it was found that in the maritime industry there are some laws and regulations regarding the inventory policy and the quantity of spare parts on ships that do not exist in the land industry. Despite this fact, in the analysed articles about spare parts inventories in the maritime industry [8, 84, 112], maritime inventories are treated in the same way as in the land industry. This fact required additional research and findings, which will be presented here. The diagrams presented in this section are a generalized representation of the principles that describe and mimic the behaviour of the stock condition in real cases.

### **2.2.1. Inventory Policies**

In order to successfully analyse inventory policy in the maritime industry, it is necessary to know how spare parts management works, i.e. what inventory policies exist. In general, there are two main types of inventory policies:

- the continuous review inventory policy (Figure 4.),
- the periodic review inventory policy (Figure 5.).

The continuous inventory policy shown in Figure 4., describes an assumed case of inventory management [63]. The inventory line starts at a level of 13 and time 0 and is constantly monitored over time. The monitored quantity slowly decreases with the spare parts consumption for the various maintenance types until it reaches a defined minimum quantity of

spare parts (line marked  $S_S$ ), which serves as a guideline for ordering. This line is called the reorder line or reorder point and is determined by previous experience of the company, the equipment manufacturer, laws and regulations or other factors (or a combination of factors).

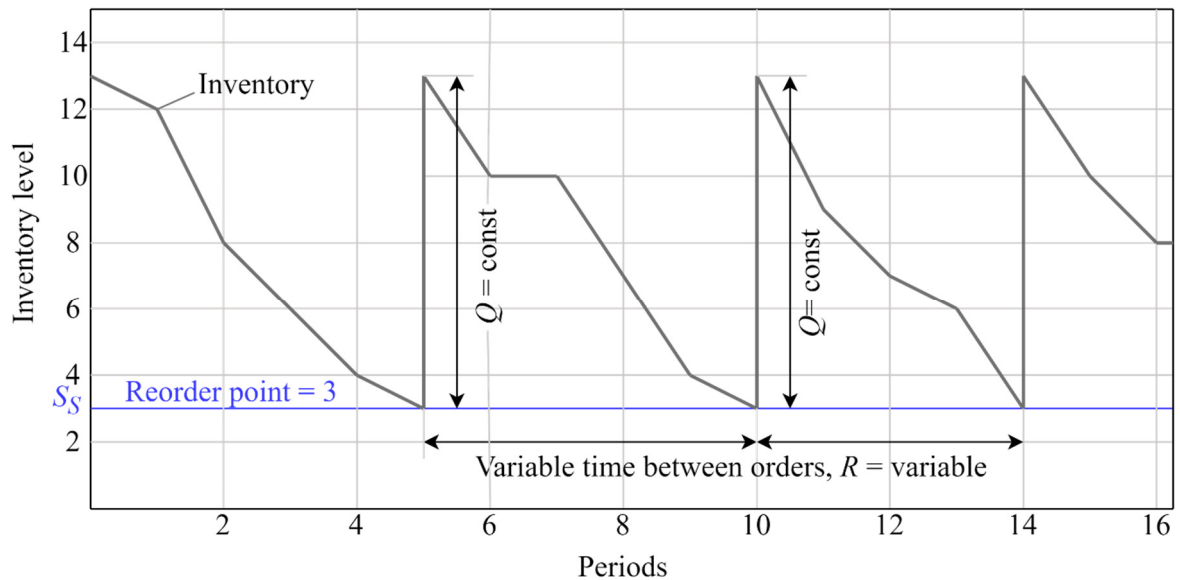
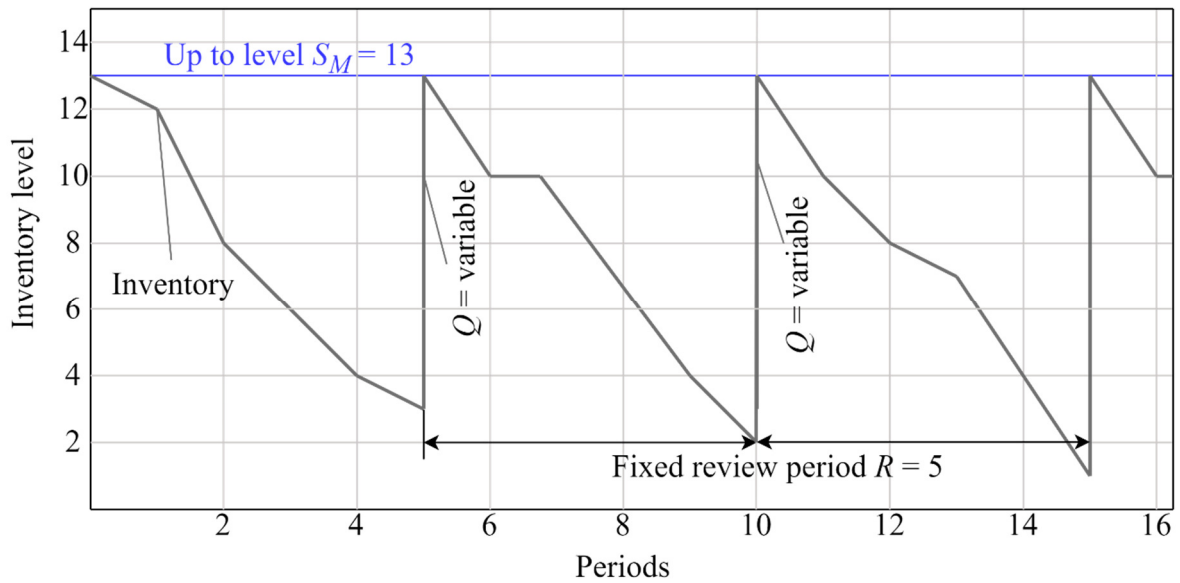

**Figure 4. The continuous review inventory policy [63, 65]**

At this point, an order is placed with a fixed order quantity  $Q$  (in this example  $Q = 10$ ), which replenishes the inventory to the initial quantity of 13. The new cycle then begins. As the decrease in stock quantity changes, the time between orders is variable and can fluctuate greatly. Therefore, this ordering policy is sometimes referred to as a variable time order policy [65]. It is important to note that in this example, the time between ordering and receiving the inventory quantity is  $S = 0$ , i.e. this section of the inventory policy is not analysed in this figure.

Another type of inventory policy is shown in Figure 5. In this figure, there is no fixed minimum inventory level (line labelled  $S_S$ ), instead there is another line labelled maximum inventory level (line labelled  $S_M$ ), which is the starting point for each order cycle. This example also starts with a stock level of  $S = 13$  and the time  $t = 0$ , and the inventory quantity slowly decreases with the spare parts consumption for the different maintenance types until it reaches a predetermined order time. At this point, an order is placed to replenish the inventory quantity to the maximum inventory level. A new cycle then begins. The main difference to the previous example is that the quantity is replenished regularly in a fixed review period, i.e. the order is placed at a specific (predetermined) time and the order quantity can be changed. As in the previous example, the time between ordering and receiving the inventory quantity is zero, i.e. this part of the inventory policy is not analysed in this Figure 5.





**Figure 5. The periodic review inventory policy [63, 65]**

Another aspect related to these two policies is the order quantity. There are two different types of order quantities in these two examples, a fixed order quantity (Figure 4.) and a variable order quantity (Figure 5.). Although it is not a rule, the fixed order quantity (the order quantity is always the same) is normally used in the continuous inventory review policy, while the variable order quantity (the order quantity is different every time) is normally used in the periodic review inventory policy.

The maritime industry is subject to special influences on spare parts management, as ships operate around the globe and usually have to meet very tight schedules and spare parts have to be delivered to different, distant ports. Therefore, a continuous review of the spare parts policy with orders that can be placed at any time is not an option (the ship may be at sea without the ability to place an order). Most of the maritime industry uses a strategy similar to the one shown in Figure 5., a strategy with a fixed order period and a variable order quantity, which can be reviewed in several examples [8, 84].

### 2.2.2. Safety stocks

As highlighted in the previous Section, Figures 4. and 5. show a simplified representation of inventory cycles where the ordering and delivery process is instantaneous. In reality, there is always a certain amount of time between ordering and delivery of the goods. During this time, the wear and tear process of the items continues and maintenance activities continue when the required parts are in stock. This part of the process (time delay for the ordering process) is explained in more detail in this section.

Figure 6. shows an example of the more realistic periodic review shown in Figure 5. The period  $R$  (order period) is the fixed period from one order to the next.

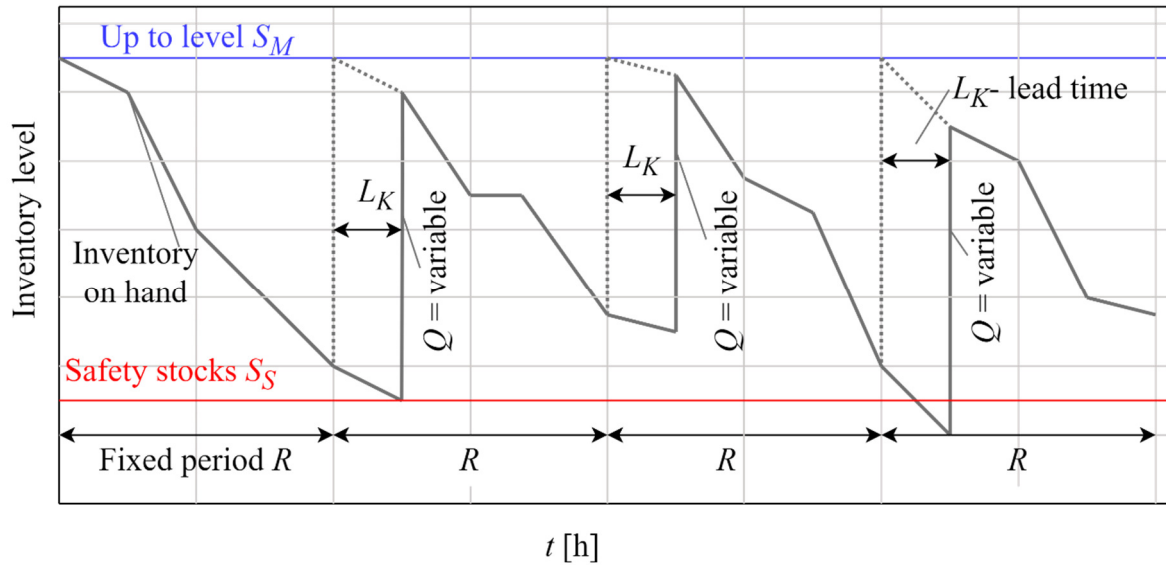

**Figure 6. Fixed period inventory policy with safety stocks [63]**

In maritime industry, it is usually determined by company regulations and therefore varies from company to company; it is usually every three or four months. The order quantity at the time of ordering in this example is a variable order quantity up to a predetermined maximum value  $S_M$ . The value  $L_K$  (which is missing in the previous examples) represents the supply lead time, one of the variables of the process that is particularly emphasised in the maritime industry, as it changes with the changes in delivery ports. Supply lead time and its effects are the subject of research by numerous authors, some of whom are from the maritime industry [84, 129].

Vandeput [63], among others, studied inventory levels in the manufacturing industry and defined safety stock (Figure 6.) as:

$$S_S = z_\alpha \sigma_d \sqrt{K} \quad (1)$$

where:

- $S_S$  – safety stock,
- $z_\alpha$  - service level factor,
- $\sigma_d$  - demand deviation,
- $K$  - the number of periods.

The definition of spare parts inventory is based on the fact that spare parts are needed for any maintenance [54]. The same author stated that the stock level  $N_i$  is the same [54]:

$$N_i = N_m + S_s \quad (2)$$

where:

$N_i$  – the inventory level,

$N_m$  – the number of spares needed in period  $n$ .

Many authors [8, 57, 63 - 66, 70, 81, 84 – 86] have researched safety stock (Figure 6. – area below the  $S_s$  line), i.e. the amount of spare parts kept on hand at all times as insurance against unexpected problems and failures, or “a straightforward way to create a buffer against these unforeseen events” [63]. Most of these authors analysed the land-based industry and defined exactly the same ordering policy and inventory levels (Figure 7.) [130].

Figure 7. shows an inventory policy that combines some features of the policies shown in Figures 5. and 6. with a maximum stock level  $S_M$ , a fixed order level  $Q_K$ , a fixed order period  $R$  and a minimum quantity of spare parts  $S_s$  (Safety minimum and reorder line at the same time).

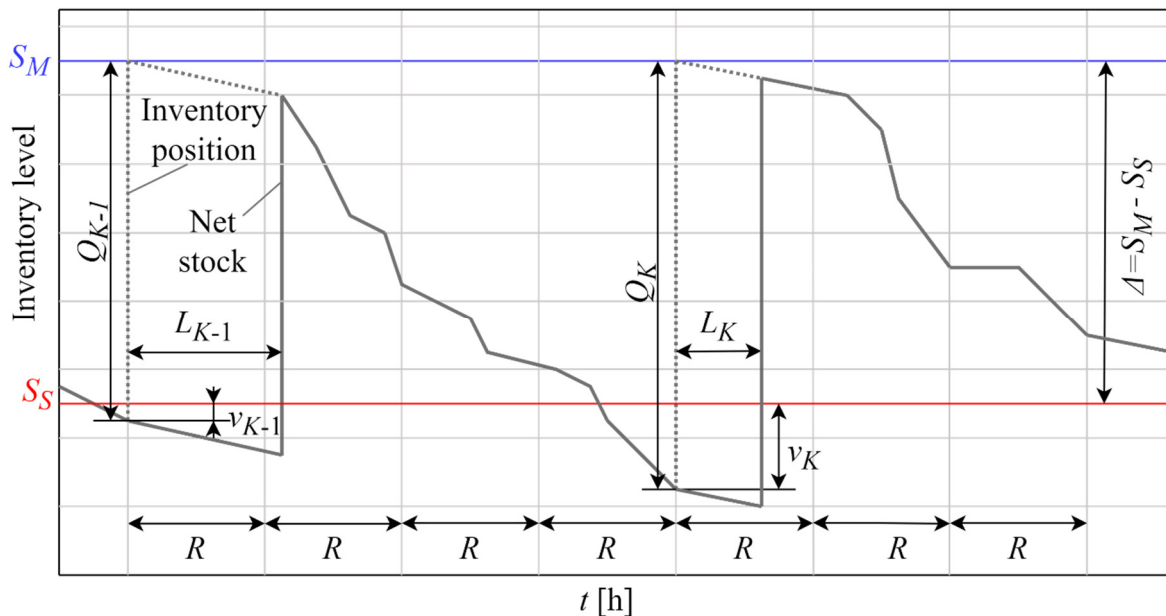
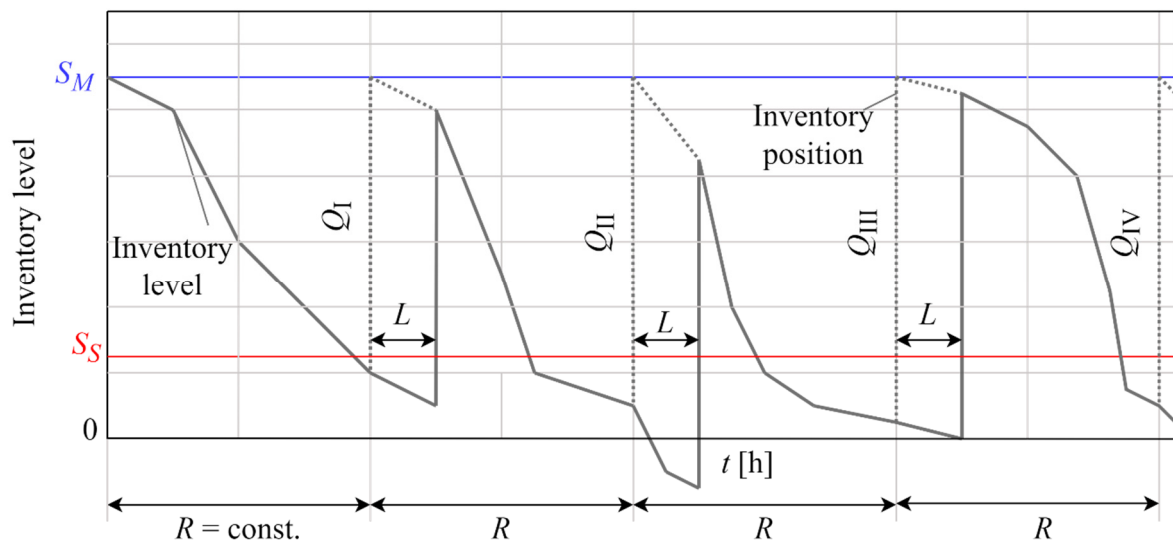

**Figure 7. Recent example of fixed period inventory policy with safety stocks [130]**

Inventory monitoring begins at the time of ordering if the stock is below the specified safety stock  $S_s$ . At this point, an order is placed that reaches a fixed stock level  $S_M$  (the quantity ordered is referred to as  $Q_K$ ). The stock level continues to fall during the period  $L_K$ , the lead time of the

order. At the end of this period, the stock is replenished. In the fixed periods  $R$  in which an order can be placed, the stock is checked again if the stock falls below the value  $S_S$  (for the value  $v_K$ , which corresponds to the value of the shortfall of the order number). If the stock is above this level, no order is placed.

Another variation of this policy is shown in Figure 8., which is taken from the book by Tongdan [131]. It represents an inventory model with safety stock and a shortage of spare parts caused by an unforeseen failure event.

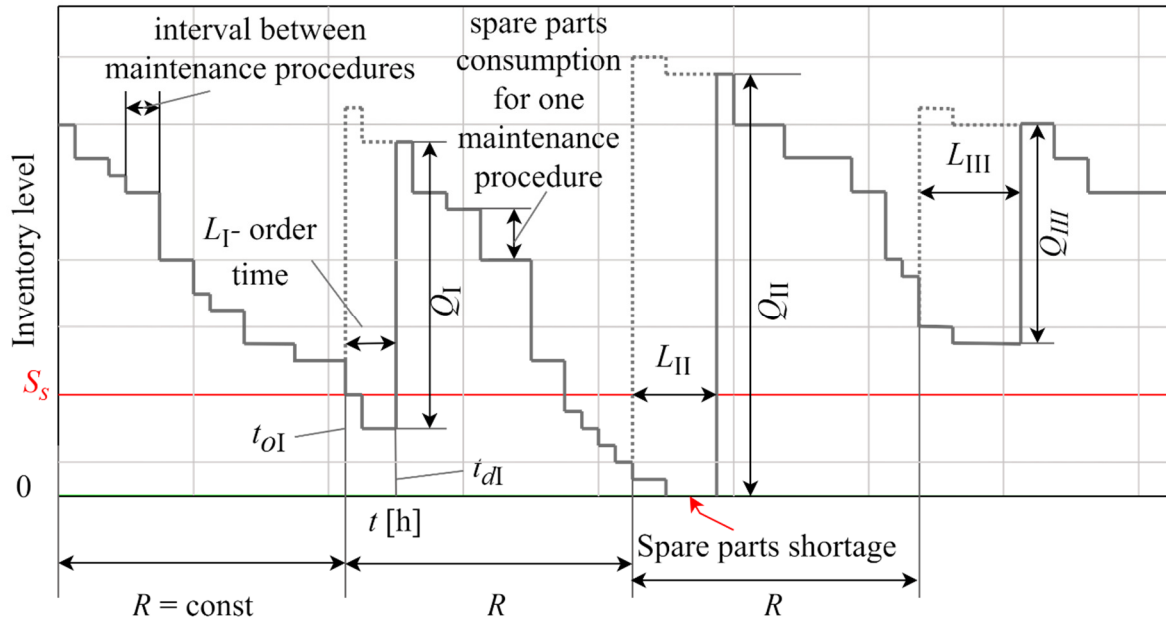

**Figure 8. Inventory policy with spare parts shortage in land based industry [131]**

In this case, stock monitoring begins with the stock level  $S_M$  and the time 0 at which consumption begins. After a predetermined time  $t$ , if the quantity is below the value  $S_S$  (safety limit), an order is placed up to a level  $S_M$  (maximum stock quantity) with a variable order quantity  $Q_K$ . After the lead time of the order  $L_K$ , an order is received and the process continues. If the demand is too high, the stock quantity is used up before the order arrives, resulting in a shortage of spare parts (parts of the curve below 0).

According to [58], a shortage of spare parts in the land-based industry leads to stoppage costs and/or unplanned shutdowns, resulting in financial losses. These losses can sometimes be less than the cost of stocking spare parts, so a balance between two options must be found.

Another example of a similar (the same) policy is presented by [8], who analysed the principles of inventory policies in the maritime industry (Figure 9.). All the principles of this policy are completely identical to the principle presented in Figure 8.



**Figure 9. Inventory policy with spare parts shortage in maritime industry [8]**

The quantity for the spare parts safety stock in the maritime industry in the analysed articles [8, 84, 112] is the same as in Equation 1. The main problem in Equation 1 is the variation in delivery times, which makes an accurate calculation of the safety stock or the safety minimum at least questionable, i.e. the estimation of the demand deviation  $\sigma_d$  (the spare parts demand in the analysed period) and the service level factor  $z_\alpha$  (the safety factor) becomes very difficult, if not impossible.

In contrast to the land-based industry, a shortage of spare parts in the maritime industry can lead to much more serious problems, such as large financial losses, possible disasters, loss of ships, cargo, human lives, etc. Therefore, the inventory policy shown in Figures 8. and 9. should not be applied in the maritime industry. It must be adapted accordingly to prevent such incidents. The next section deals with the requirements and solutions to this issue.

### 2.2.3. The safety critical spare parts minimum

During the literature review for the article [20], it was found that there are laws and regulations [132 – 135] in the maritime industry that relate to inventory policies and prescribe a minimum quantity of spare parts that must be on board as a buffer quantity for adverse events. This quantity of spare parts must provide additional safety for the ship and ensure that the ship, cargo and all personnel arrive safely at the nearest port where appropriate repairs are carried out and additional spare parts are delivered. Therefore, this additional quantity of spare parts,

referred to as safety critical spare parts, should be carried on board to provide additional safety. Safety critical spare parts should not be used for normal maintenance and should be considered as **"zero quantity"** when it comes to (managing) maritime spare parts.

This quantity can be described as a number of essential spare parts that are kept on board for unforeseen repairs to systems or equipment so that the ship can sail to the nearest port. This quantity represents another level of ship safety in the maritime industry and is not present in land-based industrial facilities. In this sense, the inventory on every ship and throughout the maritime industry should consist of:

$$N_i^{\text{mar}} = N_T + S_S + S_{CS} \quad (3)$$

where:

$N_T$  – the total number of spare parts for the order period,

$S_{CS}$  – the safety critical spare parts minimum.

The periodic inventory review policy shown in Figure 10. is a modified version of the policy described in Figure 9. with a fixed ordering period and a variable order quantity (ordering up to a certain level).

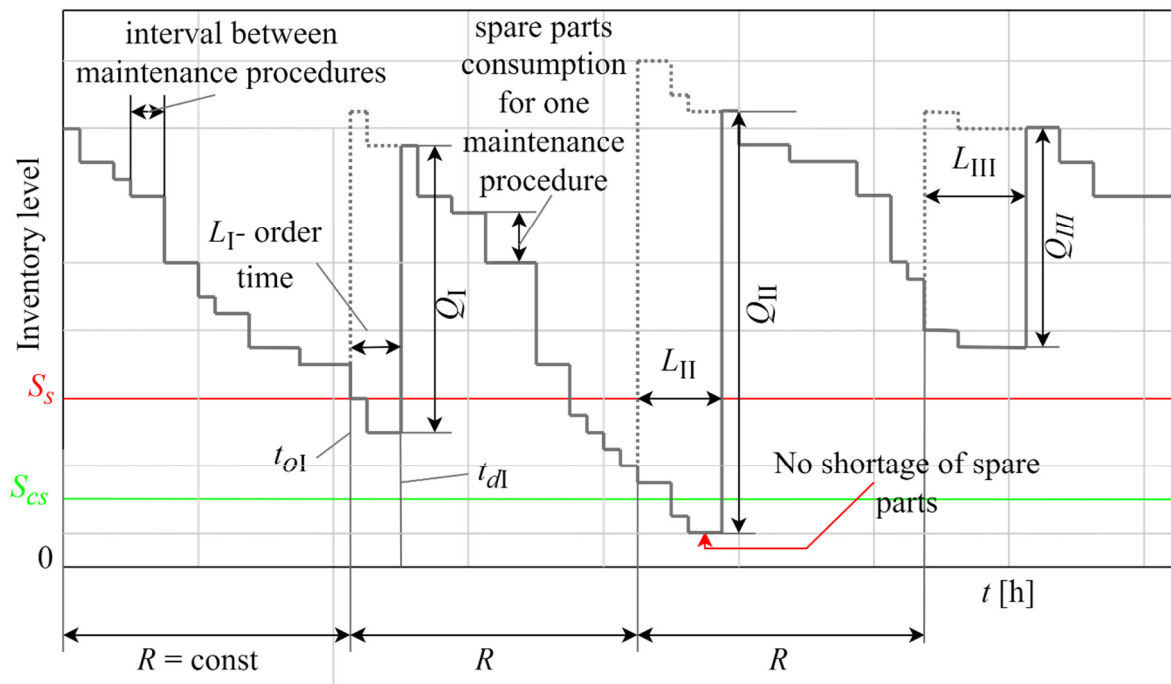

**Figure 10. Fixed period inventory policy in the maritime industry**

Most of the features are the same as in Figures 8. and 9., such as the fixed ordering period  $R$ , the lead time  $L$ , the variable ordering quantity  $Q$ , which brings the total quantity on board to a previously calculated level. Inventory monitoring starts at a time 0 and at a random level above the Safety minimum  $S_S$ .

The quantity decreases up to a certain point in time  $to_I$  when the order  $Q_I$  is placed. The order quantity is variable; it depends on the number of spare parts required in the period  $R$  until the next order. After a variable lead time  $L_I$ , the spare parts arrive at time  $td_I$  and the quantity is increased to the level  $So_I$ . During the lead time for the first supply cycle, the stock level has fallen below the safety minimum  $S_S$ , as maintenance work continued as normal. This safety minimum line, which is used to bridge the demand during the lead time, is the same as in the diagram of the onshore industrial plant.

After the spare parts delivery, the maintenance activities are continued until the predetermined time  $to_{II}$  after a fixed period  $R$ . At this time, a variable order quantity  $Q_{II}$  is placed. It will arrive at time  $td_{II}$  after a variable lead time. The maintenance activities continued normally during the second lead time and the stock level fell below the safety minimum  $S_S$ . In addition to the normal maintenance activities, there was an unexpected demand for spare parts due to corrective maintenance that used up the safety stock. In the previous examples there was a shortage of spare parts, whereas in this example there is a safety critical spare parts quantity  $S_{CS}$  which allows normal machine operation to continue until the spare parts are delivered at time  $td_{II}$  when the stock level is safely above all minimum.

Comparing Figure 10. with Figures 8. and 9., a difference can be noticed. In Figure 10., there is an additional (red) line representing the safety critical spare part minimum, which is not present in Figures 8. and 9. Despite extensive literature research [8, 57, 63 – 66, 70, 81, 84 – 86], there is no reference to this value. Even an extensive online search did not lead to any other work analysing this problem, so this is the first attempt to address it. The inclusion of this new element in the optimization models for maintenance and spare parts in the maritime industry will change the overall situation and lead to changes in total costs, which will be discussed later in this thesis.

The new approach should be combined with changes in the methodology of failure analysis to make the process simpler and more user-friendly.

The definition of this new feature of the inventory policy is only a small part that will be analysed in this thesis. The main part relates to changes to the MA-CAD method. The proposed changes are explained in more detail in the next chapter.

### **3. FAILURE ANALYSIS**

As already written, the two authors of the MA-CAD method (Maintenance Concept Adjustment and Design) have developed a simple scientific method for modelling the maintenance of ship mechanical systems, taking into account the LCC [8, 9]. In their research, they used Weibull for failure analysis and modelling. In analysing the MA-CAD method for the purpose of this research, the possibility of further modification or extension of the spare parts system was identified. The preliminary analysis concluded that it is necessary to conduct a new analysis of the spare parts process and develop additional suggestions for further modification of MA-CAD based on the recommendations and observations of the two authors of the method and experience gained through personal research. Several areas for improvement were identified as well as the possibility of replacing the Weibull analysis with a different approach.

Section 3.1. gives an overview of the failure analysis method currently used in the MA-CAD, while Section 3.2. presents the proposed replacement method. Both methods are described in general terms, and the figures in these two sections are general illustrations of both methods, showing the advantages of the PLP method under the current conditions.

#### **3.1. CURRENT METHOD**

The Weibull distribution (or rather “family of distributions” [117]) is a probability distribution that can model a variety of distributional forms. The distribution is named after the Swedish mathematician Waloddi Weibull (1887 – 1979), who described it in detail in 1939 [136]. Reliability analyses and modelling were usually modeled with the exponential distribution until the late 1950s, when it was gradually replaced by the more flexible Weibull distribution [137]. Today, due to its flexibility, it has many applications in many industries, and it is the most widely used method in all reliability analyses of technical systems [117].

There are two main forms of the Weibull distribution, depending on how many parameters are used to describe the distribution. These are the two-parameter and the three-parameter form. One of the features describing the distribution is the Probability Density Function (PDF), which in the case of three parameters is as follows [117]:



$$f(t|\beta_w, \eta, \mu) = \frac{\beta_w}{\eta} \left( \frac{t-\mu}{\eta} \right)^{\beta_w-1} \cdot \exp\left( -\frac{t-\mu}{\eta} \right)^{\beta_w} \quad (4)$$

where:

$\eta$  – Weibull scale parameter,

$\beta_w$  – Weibull shape parameter,

$\mu$  – Weibull location parameter (or the threshold parameter).

If the parameter  $\mu = 0$ , the distribution becomes a 2-parameter Weibull distribution with probability density function [117]:

$$f(t|\beta_w, \eta) = \frac{\beta_w}{\eta} \left( \frac{t}{\eta} \right)^{\beta_w-1} \cdot \exp\left( -\frac{t}{\eta} \right)^{\beta_w} \quad (5)$$

There are some distinguishing features with regard to the Weibull parameters, especially the shape parameter [138]. Figure 11. shows how the value of the parameter  $\beta_w$  influences the shape of the PDF curve with constant parameter  $\eta$  (in this example it is fixed at the value  $\eta = 40$  hours). If the value of  $\beta_w < 1$  (0.5 in this case), the PDF curve slopes steeply downwards towards a hyperbolic curve, as shown in blue) and the declination rate decreases with time.

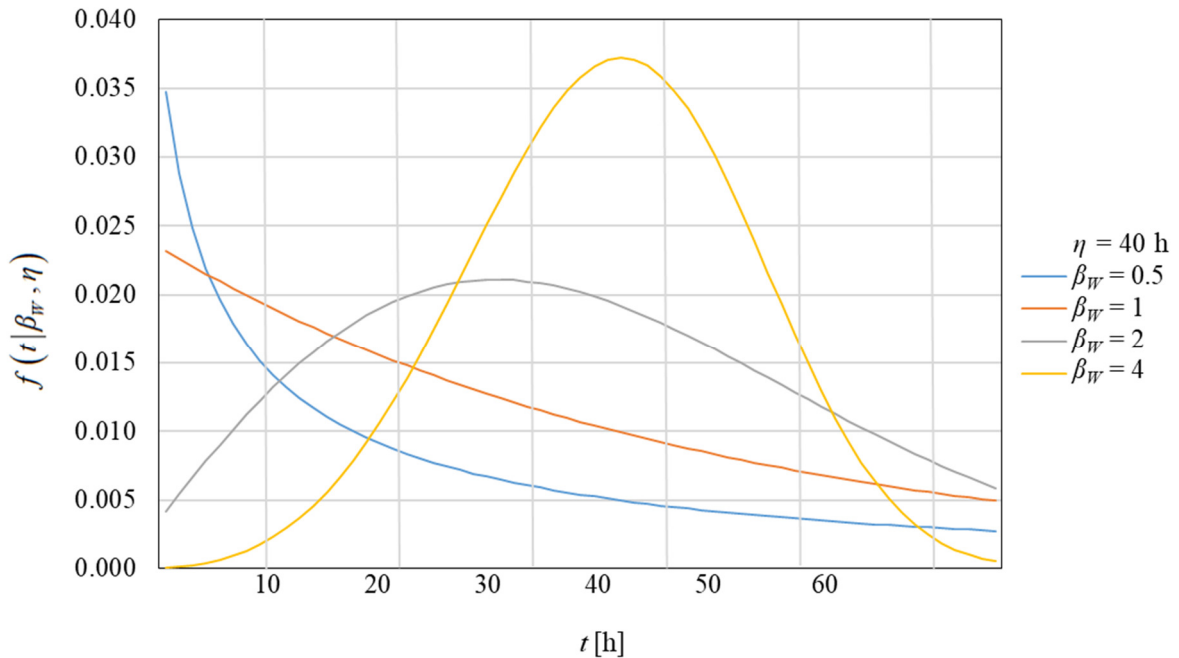

**Figure 11. Influence of parameter  $\beta_w$  on Weibull PDF (based on [138])**

At a value of  $\beta_W = 1$ , the PDF curve has the shape of a slightly sloping curve (tending towards a true exponential curve, shown by the orange colour), and the rate of declination also decreases with time. When  $\beta_W > 1$  (two curves in this example), the peak of the curve increases as the parameter  $\beta_W$  value increases, as shown by the grey and yellow curves, with the yellow curve having twice the value of parameter  $\beta_W$  then the grey curve.

The following characteristics also describe the Weibull distribution:

- the Cumulative Distribution Function (CDF), which describes the probability of equipment failure over time [117]:

$$F(t|\beta_W, \eta) = 1 - \exp\left(-\frac{t}{\eta}\right)^{\beta_W} \quad (6)$$

- the Reliability Function or Survivor Function, which describes the probability that the lifetime of an equipment exceeds a certain value [117]:

$$R(t|\beta_W, \eta) = \exp\left(-\frac{t}{\eta}\right)^{\beta_W} \quad (7)$$

- the Failure Rate Function or Hazard Function, which describes the probability of an equipment failure at time  $t$ , assuming that the equipment has already survived this time [117]:

$$\lambda(t|\beta_W, \eta) = \frac{f(t|\beta_W, \eta)}{R(t|\beta_W, \eta)} = \frac{\beta_W}{\eta} \left(\frac{t}{\eta}\right)^{\beta_W-1} \quad (8)$$

Figure 12. shows the influence of the parameter  $\beta_W$  on the Weibull failure rate. The value of the shape parameter  $\beta_W < 1$  (blue line,  $\beta_W = 0.5$ ) indicates that the failure rate decreases with time.

The value  $\beta_W = 1$  (marked with an orange line) has the shape of a straight line and indicates that the failure rate is constant over time, and in this case this distribution becomes an exponential distribution. If the value of the parameter  $\beta_W > 1$  (grey line,  $\beta_W = 4$ ), the failure rate increases over time and describes a process that ages over time and the probability that the equipment will fail increases over time. The larger the value  $\beta_W$  is, the steeper the curve rises.

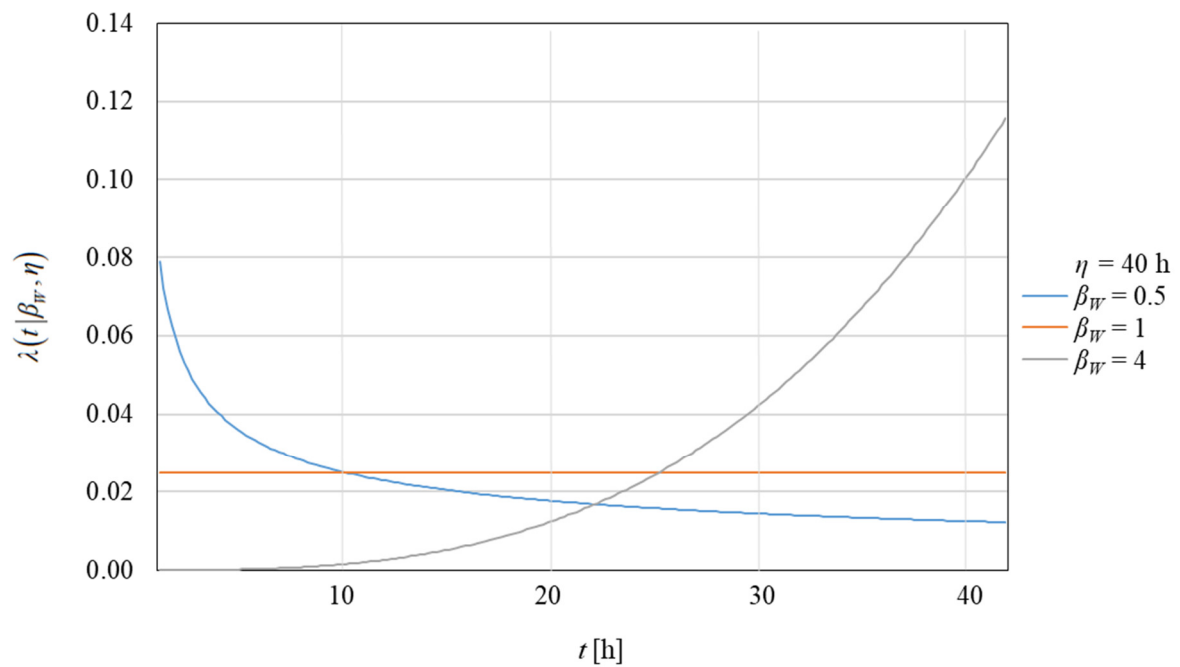

**Figure 12. Influence of parameter  $\beta_W$  on Weibull failure rate (based on [138])**

The value of the scale parameter  $\eta$  affects the PDF in a different mode (Figure 13.). If the value of the parameter  $\eta$  is increased without changing other parameters (in this case, the value of the parameter  $\beta_W = 2$ ), there is a stretching effect on the abscissa.

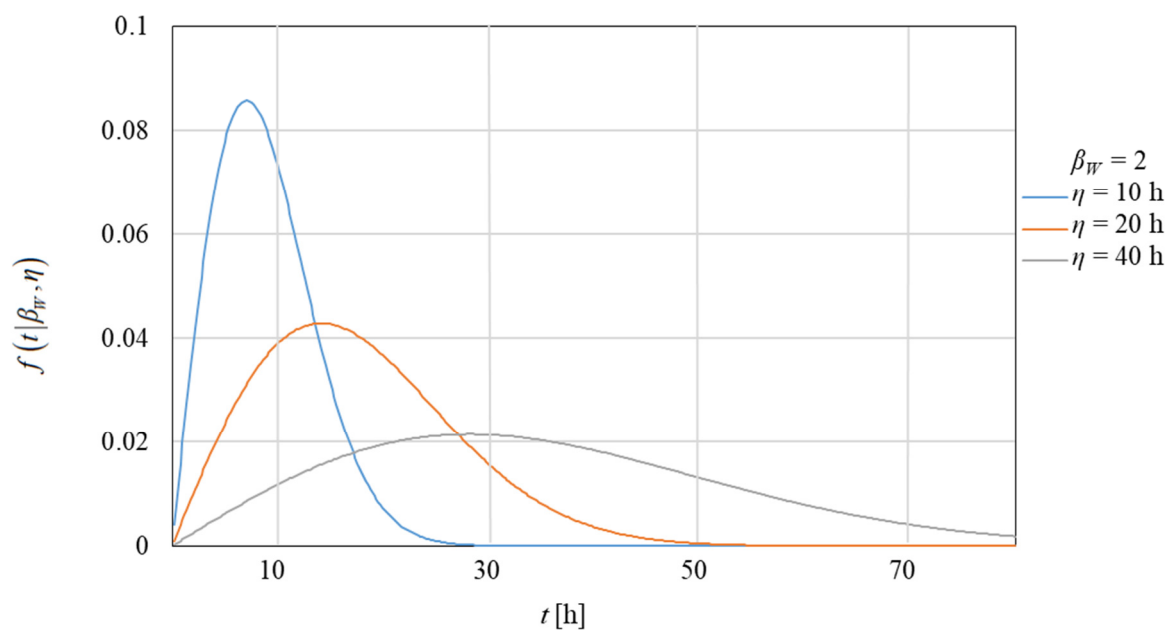

**Figure 13. Influence of parameter  $\eta$  on Weibull PDF (based on [138])**

Since the value under the curve is constant, the peak of the curve gradually decreases as  $\eta$  is increased. Figure 13. shows the PDF curves for three different values of  $\eta$ , where this stretching can be observed. The blue curve has a value of  $\eta = 10$  h and the curve has a parabolic shape that rises and falls quite steeply. The orange line shows the PDF where  $\eta$  has a double value of  $\eta = 20$  hours, the total height of the curve is halved, but the slopes are much milder. The third curve, the grey one, is created with  $\eta = 40$  h and is both the lowest and the longest curve.

Many researchers [8, 9, 12, 21 – 23, 38, 57, 60, 81, 85,87, 90, 93, 100, 104, 106, 111] use the 2-parameter Weibull distribution because using the location parameter “*causes some technical difficulties and makes valid inferences about the parameters or functions of the parameters particularly difficult*” [138], moreover, there are many more applications and research results for the 2-parameter Weibull distribution [137]. The 2-parameter Weibull distribution is also used in the MA-CAD method and is accepted as the starting point for further analysis in this thesis.

The determination of the Weibull parameters is a process for which there are various solutions, as there is no analytical solution to the problem. One of the common estimation methods is Maximum Likelihood Estimate (MLE) [115].

The MLE of the Weibull parameters starts with the likelihood function [115]:

$$L(t|\beta_w, \eta) = \prod_{i=1}^n f(t|\beta_w, \eta) = \prod_{i=1}^n \frac{\beta_w}{\eta} \left(\frac{t}{\eta}\right)^{\beta_w-1} \cdot \exp\left(-\frac{t}{\eta}\right)^{\beta_w} \quad (9)$$

The MLE is the value of the unknown parameter that maximizes the likelihood function or the log-likelihood function, where [115]:

$$\frac{\partial \ln L(t|\beta_w, \eta)}{\partial \beta_w} = \frac{\partial \ln \prod_{i=1}^n f(t|\beta_w, \eta)}{\partial \beta_w} = \frac{\partial \ln \left[ \prod_{i=1}^n \frac{\beta_w}{\eta} \left(\frac{t}{\eta}\right)^{\beta_w-1} \cdot \exp\left(-\frac{t}{\eta}\right)^{\beta_w} \right]}{\partial \beta_w} = 0 \quad (10)$$

and

$$\frac{\partial \ln L(t|\beta_w, \eta)}{\partial \eta} = \frac{\partial \ln \prod_{i=1}^n f(t|\beta_w, \eta)}{\partial \eta} = \frac{\partial \ln \left[ \prod_{i=1}^n \frac{\beta_w}{\eta} \left(\frac{t}{\eta}\right)^{\beta_w-1} \cdot \exp\left(-\frac{t}{\eta}\right)^{\beta_w} \right]}{\partial \eta} = 0 \quad (11)$$

The MLEs of the parameters  $\beta_w$  and  $\eta$  are estimated by solving Equations 10 and 11; they are reduced to [115]:

$$\frac{\partial \ln L(t|\beta_w, \eta)}{\partial \beta_w} = \frac{n}{\beta_w} - n \ln \eta - \frac{\sum_{i=1}^n t_i^{\beta_w} - \ln \eta \cdot \sum_{i=1}^n t_i^{\beta_w}}{\eta \cdot \beta_w} + \ln \sum_{i=1}^n t_i = 0 \quad (12)$$

$$\frac{\partial \ln L(t|\beta_w, \eta)}{\partial \eta} = -\frac{n \cdot \beta_w}{\eta} + \frac{\beta_w}{\eta^{(\beta_w+1)}} \cdot \sum_{i=1}^n t_i^{\beta_w} = 0 \quad (13)$$

After removing  $\eta$  from both equations, the MLEs for the parameters can be estimated [115]:

$$\frac{1}{\beta_w} - \frac{\sum_{i=1}^n t_i^{\beta_w} \cdot \ln t_i}{\sum_{i=1}^n t_i^{\beta_w}} + \frac{1}{n} \cdot \sum_{i=1}^n t_i = 0 \quad (14)$$

$$\hat{\eta} = \left( \frac{1}{n} \cdot \sum_{i=1}^n t_i^{\hat{\beta}_w} \right)^{\frac{1}{\hat{\beta}_w}} \quad (15)$$

Equation 15 can be easily solved with a calculator, i.e. the MLE of the parameter  $\eta$  can be determined analytically by substituting the estimated value of  $\hat{\beta}_w$ . At the same time, Equation 14 cannot be solved analytically, but must be solved numerically, which makes the estimation somewhat more difficult.

As it turns out, determining the Weibull parameters is not a simple process, which discourages the use of this model in the maritime industry, which is already known for cost-cutting and always trying to hire cheaper (and therefore less competent and with less knowledge) labour [51]. For this reason, the intention of this thesis is to replace the Weibull analysis to make the MA-CAD method more user-friendly, bearing in mind that “*there are only a few alternatives to the Weibull*” [117].

As already emphasised, MLE is only one (albeit the most commonly used [139]) method for determining the parameters of this distribution. It is very often the case that the results obtained by different methods of parameter determination differ significantly [140], and the question of the credibility of the parameter determination arises. To reduce this problem, the concept of the confidence interval was introduced, where it is a measure of the accuracy of parameter estimation. Abernethy et al. defined the confidence interval as “*the frequency with which the interval calculation method could be expected to contain the parameter if there were repeated applications of the method*” [117].

He described a simple method for determining confidence limits for Weibull parameters using two equations [117]:

$$\hat{\beta}_w \cdot \exp\left(\frac{-0.78 \cdot Z_{\alpha/2}}{\sqrt{n}}\right) \leq \beta_w \leq \hat{\beta}_w \cdot \exp\left(\frac{0.78 \cdot Z_{\alpha/2}}{\sqrt{n}}\right) \quad (16)$$

$$\hat{\eta} \cdot \exp\left(\frac{-1.05 \cdot Z_{\alpha/2}}{\hat{\beta}_w \sqrt{n}}\right) \leq \eta \leq \hat{\eta} \cdot \exp\left(\frac{1.05 \cdot Z_{\alpha/2}}{\hat{\beta}_w \sqrt{n}}\right) \quad (17)$$

where:

$Z_{\alpha/2}$  – the upper  $\alpha/2$  point of the standard normal distribution.

The same author [117] recommended commonly used values for  $Z_{\alpha/2}$ , which are listed in Table 1.

**Table 1. Commonly used confidence levels [117]**

Confidence level	$Z_{\alpha/2}$
99%	2.576
95%	1.960
90%	1.645

Following these instructions, it is noted that this method should be used for large, complete samples and that the method is not recommended for use with very few failures (small sample) [117]. Although Abernethy et al. do not explicitly state what size should be considered a small sample, the definition and problem description are clear in Figure 14. [141], where the confidence interval becomes narrower as the sample size increases, while it is very wide for small samples.

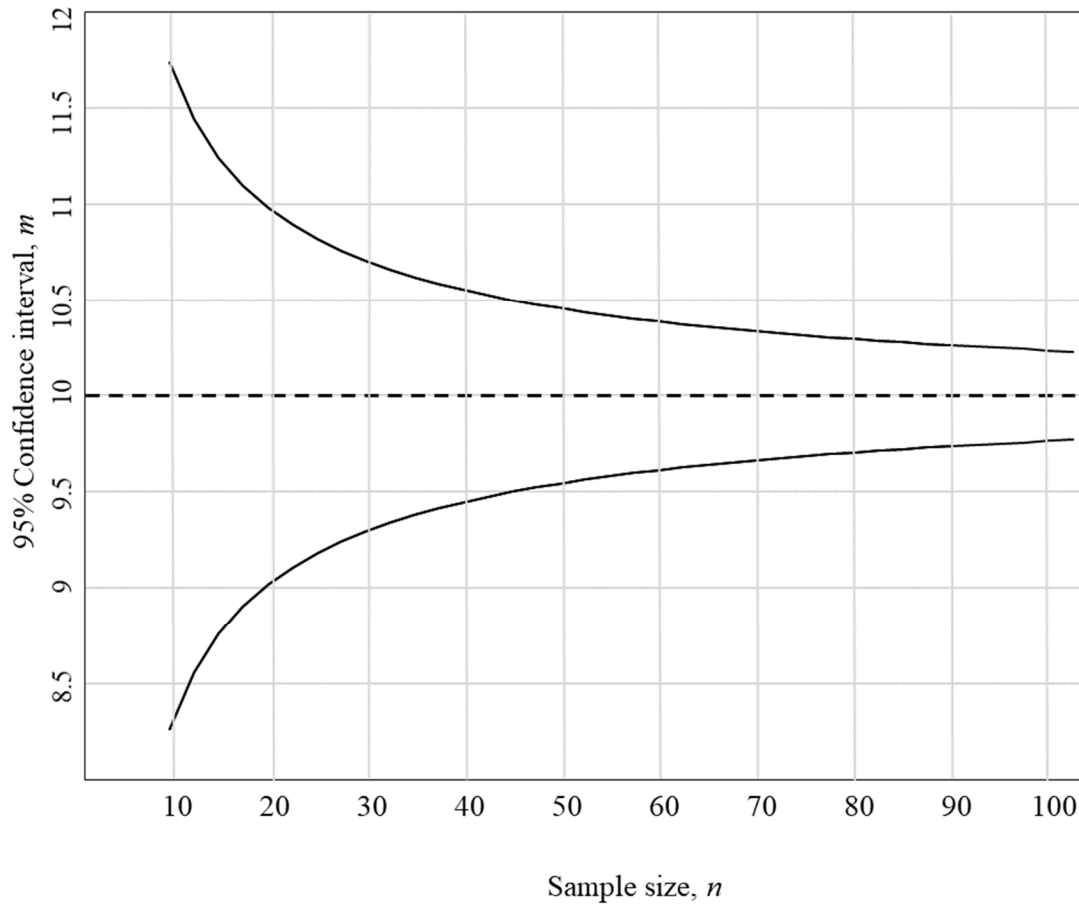

**Figure 14. Sample size effect on  $\beta_w$  [141]**

For small samples, Abernethy et al. [117] recommend the method(s) later described in detail by Nelson [142], which demonstrates the determination of confidence limits. Mann and Fertig [143] simplified the entire procedure for a small number of failures and provided tables for the multiplication of parameters to obtain confidence limits. Bain and Engelhardt in their study [144] also dealt with the small sample size and the associated problem and also provided tables with already determined confidence intervals. Lawles [145] and Toman et al. [146] also investigated MLEs and confidence intervals of the Weibull distribution and extended their research to confidence intervals of reliability by providing tables as a tool for simpler calculations.

As has been shown here, despite its widespread use and diversity, Weibull analysis has a number of shortcomings that can complicate the application of this method in the maritime sector. For maritime applications, it would be ideal to choose a model with a simpler mathematical approach, which would make failure modelling more popular.

According to Zapata et al. [147], there are several common misconceptions about modelling repairable systems and one of them is that the Weibull model can be universally used for modelling failures. Even Waloddi Weibull, the author of this distribution, “*did not claim that it always worked or even that it was always the best choice*” [117]. A clue to the answer to the question of which model to choose as a replacement for Weibull is provided by Rigdon and Basu [24], who write that PLP is one of the established methods for failure time analysis of repairable systems, known for the simplicity of statistical inference procedures [24].

When searching the literature on PLP, other similar opinions can be found. Mazzola et al. show how PLP can be successfully used for modelling repairable systems, since the approach normally used for non-repairable systems (Weibull) is not satisfactory [148]. They point out that the Weibull distribution, although versatile and widely used, is not suitable for analysing complex repairable systems and that the failure times of the system under these conditions follow a NHPP [148].

Chen [149] emphasized in his dissertation the fact that the intensity function changes as the system ages and that an NHPP should be chosen under this assumption [149] and that the commonly used approach is the PLP.

The last and most concrete argument is put forward by Guida et al. They criticize the misunderstanding that existing methods for non-repairable systems can also be applied to repairable systems [150]. They emphasize that for reliability growth and overhaul analyses, a more realistic model is needed that assumes that a repair returns the system to its pre-failure state. Under these assumptions, they also recommend NHPP. Another argument in favour of using PLP is given in the same article, which confirms the opinion of [150]: “*A practical aspect which has further motivated the use of such a model is the availability of simple classical estimation procedures*”.

Considering all that has been mentioned in this section, the conclusion is that PLP is suitable, i.e. a good method to replace Weibull in failure analysis in the MA-CAD method. In the next part, PLP is explained in more detail, its characteristics and are listed in detail. In addition to the features mentioned above, special attention is paid to the simpler calculation of PLP MLEs, which further simplifies the whole failure analysis procedure. After the general part with the PLP description, an application proposal for the method is explained.



### 3.2. PROPOSED REPLACEMENT METHOD

The reliability growth model was first published by Duane in 1964 [118]. In his work, he analysed the log-log plot and came to the conclusion that the cumulative failure rate is approximately linear to the cumulative test time. This discovery is illustrated in Figure 15. in a simplified diagram where dots represent failures distributed over time and the straight blue line represents the natural logarithms of cumulative failure rate linear to the cumulative test time.

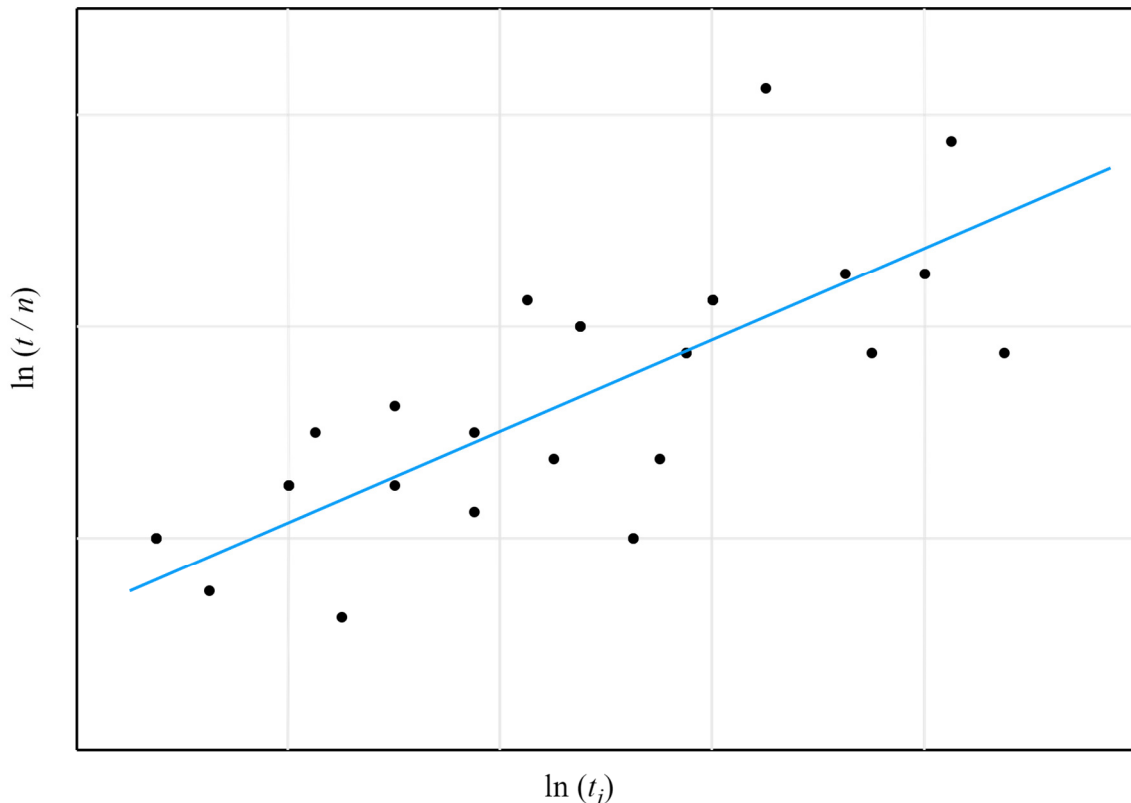

**Figure 15. Duane claim (based on [118])**

Crow continued the research on Duane's postulate and claimed that the model can be stochastically represented as a Weibull process, thus developing the AMSAA model [119], i.e. a process that can be used for reliability growth. This model later became known as the Power Law Process or Weibull process.

Because of these two authors, the model is sometimes also called the Duane model (after its main author) or the AMSAA model (after the first application shown by Crow [119]). Today, the PLP model is often used for reliability growth [24, 121 – 123]. The best description of the model comes from [24], who say that it is "*more realistic, a priori, in most situations*". Some authors use this model for spare parts modelling, such as Kontrec and Panić [22], who linked

spare parts ordering to reliability using the PLP method, and Qarahasanlou et al. [124] and Jacobs [151], who used the PLP model for spare parts prediction based on failure data analysis.

PLP can be described as NHPP with a particular form of the intensity function [24] as the main determination:

$$u(t|\beta_{PLP}, \theta) = \frac{\beta_{PLP}}{\theta} \left(\frac{t}{\theta}\right)^{\beta_{PLP}-1}; \beta_{PLP}, \theta, t > 0 \quad (18)$$

where:

$\beta_{PLP}$  – PLP shape parameter,  
 $\theta$  – PLP scale parameter.

The following characteristics also describe the PLP:

- Mean value function:

$$m(t|\beta_{PLP}, \theta) = \left(\frac{t}{\theta}\right)^{\beta_{PLP}} \quad (19)$$

- Intensity function

$$\lambda(t|\beta_{PLP}, \theta) = \frac{\beta_{PLP}}{\theta} \cdot t^{\beta_{PLP}-1} \quad (20)$$

There are different approaches when describing PLP; some authors use  $\lambda_{PLP}$  instead of  $\theta$ , the ratio is shown by Equation 21:

$$\lambda_{PLP} = \frac{1}{\theta^{\beta_{PLP}}} \quad (21)$$

The values of the parameters influence the shape of the curve. The value of the shape parameter is an important parameter, just like in the Weibull distribution. In the case of  $\beta_{PLP} = 1$  (orange line in Figures 16. and 17.), the system becomes a homogeneous poison process, while in the case of  $\beta_{PLP} \neq 1$  PLP may be a suitable model for reliability calculation. Figure 16. presents a case with constant  $\theta = 100$  hours. When the parameter  $\beta_{PLP} < 1$  (this is shown on Figure 16. with the blue line where  $\beta_{PLP} = 0.5$ ), the probability density function decreases, which

shows that the reliability of the system improves. When  $\beta_{PLP} > 1$  the system deteriorates over time (this is shown in Figure 16. with the grey line where  $\beta_{PLP} = 1.5$  and with the yellow line where  $\beta_{PLP} = 3$ ). The parameter  $\beta_{PLP}$  is twice as large in the case of the yellow line, which shows that the system deteriorates faster the larger the parameter  $\beta_{PLP}$  is.

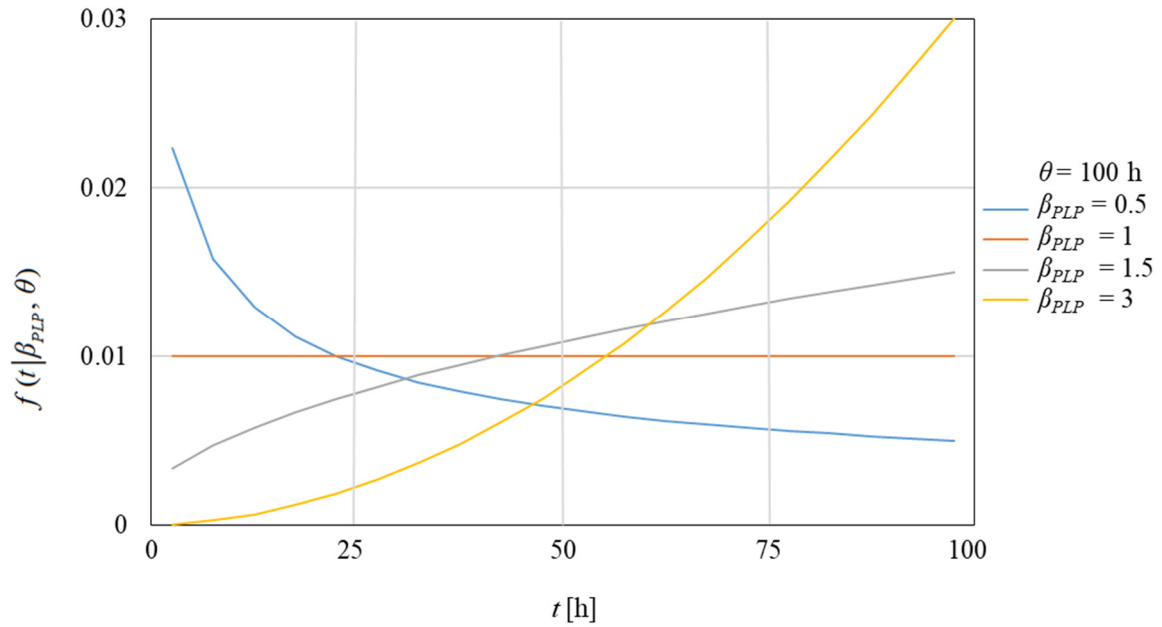

**Figure 16. Influence of parameter  $\beta_{PLP}$  on PLP PDF with constant  $\theta$**

Figure 17. which is similar to Figure 16. also shows the influence of values of  $\beta_{PLP}$  on PDF, this time with constant  $\lambda_{PLP} = 0.5$ .

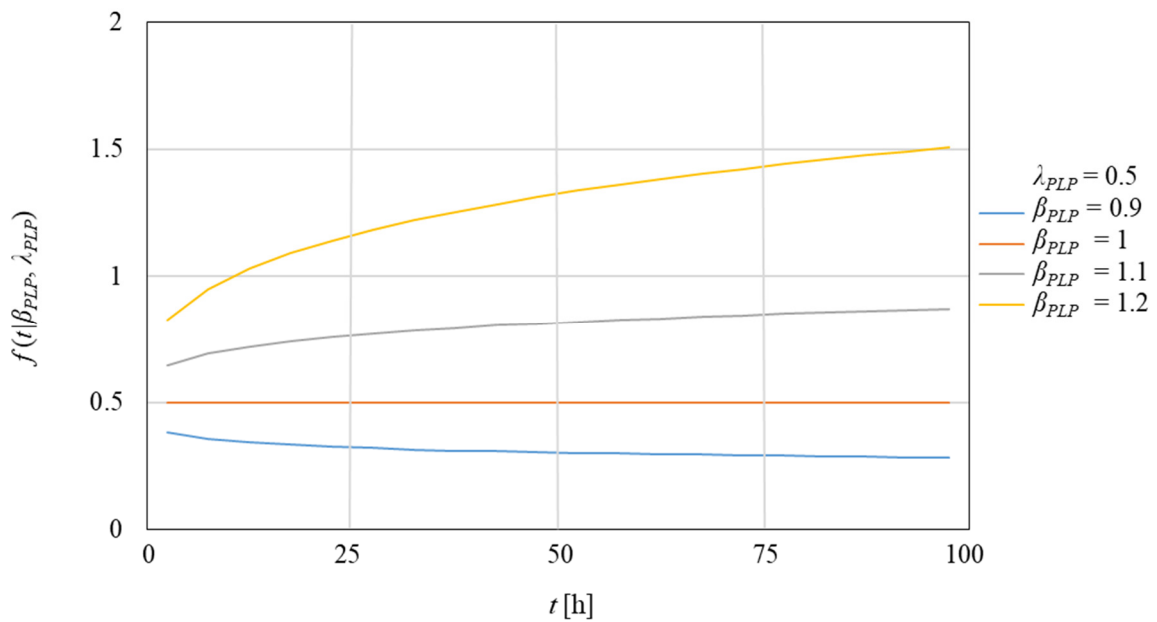
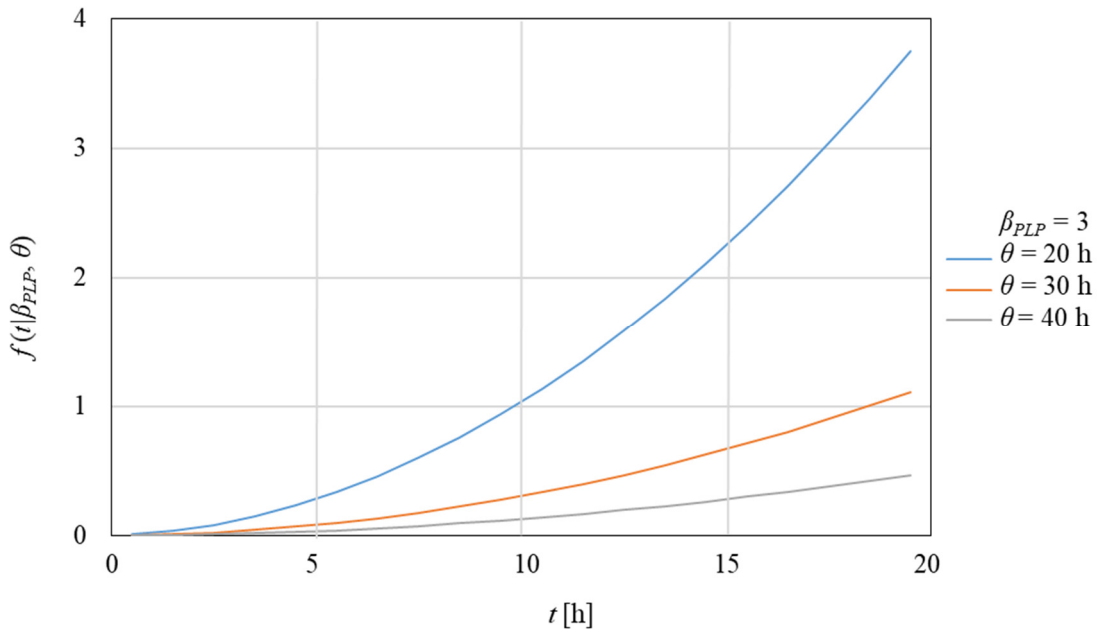

**Figure 17. Influence of parameter  $\beta_{PLP}$  on PLP PDF with constant  $\lambda_{PLP}$**

If the value of the parameter  $\beta_{PLP} < 1$  (Figure 17., blue line,  $\beta_{PLP} = 0.9$ ), the probability density function decreases and the reliability of the system improves. The grey line with  $\beta_{PLP} = 1.1$  and the yellow line with  $\beta_{PLP} = 1.2$  in Figure 17. show the deterioration of the system with two different slopes. The figure shows that the larger the parameter  $\beta_{PLP}$ , the faster the deterioration.

Comparing Figures 16. and 17. with Figure 11., the curves are similar and it can be concluded that in both cases the parameter  $\beta$  (either Weibull or PLP) determines the reliability of the system.

The influence of the parameter  $\theta$  (with fixed value of the parameter  $\beta_{PLP}$ ) on the PLP PDF is shown in Figure 18. In this figure, the parameter  $\beta_{PLP}$  is constant,  $\beta_{PLP} = 3$ .



**Figure 18. Influence of parameter  $\theta$  on PLP PDF with constant  $\beta_{PLP}$**

Three different values of  $\theta$  are shown in the Figure, the smallest one with value  $\theta = 20$  h in blue, the orange line with  $\theta = 30$  h and the grey line with the largest parameter  $\theta = 40$  h.

Analogous to the Weibull model, the slope parameter reduces the steepness of the slope. The smallest parameter value, shown in blue, is very steep, while the slope of the grey line is much less steep. As with the Weibull distribution, the PLP parameters can also be estimated using MLE, which is one of the most common estimation methods. The estimation of PLP parameters also starts with the likelihood function of the probability density function:

$$L = \prod_{i=1}^n f(t_i | \beta_{PLP}, \theta) \quad (22)$$

PLP probability density function can be written as [152 – 154]:

$$f(t_1, t_2, \dots, t_n | \beta_{PLP}, \theta) = \left( \frac{\beta_{PLP}}{\theta} \right)^n \cdot \left( \prod_{i=1}^n \frac{t_i}{\theta} \right)^{\beta_{PLP}-1} \cdot \exp\left( -\frac{t_n}{\theta} \right)^{\beta_{PLP}} \quad (23)$$

The likelihood function given in Equation 22 is expanded to [152 – 154]:

$$L(t | \beta_{PLP}, \theta) = \prod_{i=1}^n \frac{\beta_{PLP}}{\theta} \left( \frac{t_i}{\theta} \right)^{\beta_{PLP}-1} \cdot \exp\left( -\int_0^s \frac{\beta_{PLP}}{\theta} \left( \frac{t}{\theta} \right)^{\beta_{PLP}-1} dt \right) \quad (24)$$

The MLEs of  $\beta$  and  $\theta$  are obtained by solving the likelihood Equations for the parameters  $\beta$  and  $\theta$ :

$$\frac{\partial \ln L(t | \beta_{PLP}, \theta)}{\partial \beta_{PLP}} = 0 \quad (25)$$

$$\frac{\partial \ln L(t | \beta_{PLP}, \theta)}{\partial \theta} = 0 \quad (26)$$

The results vary depending on the method of data collection for the analysis, i.e. depending on the value  $s$ . If the data collection ends at a certain number of failures, the method is called "failure truncated", and in this case  $s = t_n$ , where  $t_n$  is the time of the last failure. If the data collection ends at a certain point in time, the method is called "time truncated". In this case,  $s = t_T$ , where  $t_T$  is the time of the end of data collection.

Solving Equations 25 and 26 for failure truncated data yields [152 – 154]:

$$\hat{\beta}_{PLP}^{FT} = \frac{n}{\sum_{i=1}^{n-1} \ln \frac{t}{t_i}} \quad (27)$$

$$\hat{\theta}^{FT} = \frac{t_n}{n^{\hat{\beta}_{PLP}^{FT}}} \quad (28)$$

where:

$n$  – number of failures,

$t_n$  – time of the last failure (time of failure truncation).

Solving Equations 25 and 26 for time truncated data yields [152 – 154]:

$$\hat{\beta}_{PLP}^{TT} = \frac{n}{\sum_{i=1}^n \ln \frac{t_T}{t_i}} \quad (29)$$

$$\hat{\theta}^{TT} = \frac{t_T}{n \frac{1}{\hat{\beta}_{PLP}^{TT}}} \quad (30)$$

where:

$t_T$  – time of the end of data collection (time of time truncation).

Similar to Weibull MLE; in the case of failure truncated data, MLE of the parameter  $\beta_{PLP}$  cannot be obtained by analytically solving Equation 27, but must be solved numerically. On the other hand, in the case of time truncated data, MLEs can be obtained analytically by solving Equations 29 and 30.

In order to know which approach is suitable for determining the MLE, it is important to know what is the most common case in the maritime industry. Since failures are (or should be) analysed from time to time (e.g. every three months, semi-annually, or annually), it can be assumed with a high degree of confidence that all data are time truncated.

In the case of time truncated data, the MLE of the intensity function is expressed as follows [24]:

$$\hat{u}(t | \hat{\beta}_{PLP}, \hat{\theta}) = \frac{n \cdot \hat{\beta}_{PLP}}{t_i} \quad (31)$$

Similar to Weibull, the question of the credibility of the parameter determination also arises here. Here, too, the concept of the confidence interval for parameters, reliability and function intensity was introduced to address the question of credibility [120, 121, 152 – 155]. To simplify the determination of confidence intervals, the authors have created and used tables. Some examples of tables and their use are Crow [120, 121], Bain and Engelhardt [144, 154] and Finkelstein [155].

Crow, one of the founders of this method, recommended expressing the intensity function in terms of 95% confidence intervals and provided  $\Pi_1$  and  $\Pi_2$  estimators, which can be found in Crow [121]. Following these instructions, the confidence interval for  $\hat{u}(t)$  is determined using Equations 32, 33, 34 [24], where the following applies:

$$CI_{LL}(\hat{u}) = \frac{\hat{u}(t | \hat{\beta}_{PLP}, \hat{\theta})}{\Pi_1} \quad (32)$$

$$CI_{UL}(\hat{u}) = \frac{\hat{u}(t | \hat{\beta}_{PLP}, \hat{\theta})}{\Pi_2} \quad (33)$$

$$CI_{LL}(\hat{u}) \leq \hat{u}(t | \hat{\beta}_{PLP}, \hat{\theta}) \leq CI_{UL}(\hat{u}) \quad (34)$$

where:

$CI_{LL}(\hat{u})$  – lower confidence limit,

$CI_{UL}(\hat{u})$  – upper confidence limit.

This method is used for spare parts prediction in an interval using an appropriate confidence interval.

After describing the failure analysis methods and explaining why the Weibull is replaced by the PLP, it is shown how the parameters can be estimated using the MLE method for PLP. The next step is to determine how and where to use the results of the PLP failure analysis.

### 3.3. POWER LAW PROCESS USE

The PLP is used in this thesis for a variety of purposes, completely replacing Weibull as the main tool for calculating the future consumption of spare parts (i.e. prediction), for calculating proposals to change the planned maintenance schedule according to the desired reliability, and for optimizing maintenance and spare parts.

### 3.3.1. Spare parts prediction

The spare parts forecast in a period is based on the assumption that the expected number of corrective maintenances in an analysed period is equal to the number of failures  $H(t)$  in this period. It is important to note that the number of failures is always an integer.

If the Weibull model is used, the expected number of failures  $H^W(t)$  can be expressed as follows [156 – 158]:

$$H^W(t|\beta_w, \eta) = \left(1 - \frac{n}{N_u}\right) - \left(1 - \frac{n}{N_u}\right)^{\left(\frac{t_i}{t_{i+R}}\right)^{\beta_w}} \quad (35)$$

where:

- $n$  – number of failures,
- $N_u$  – number of units (components),
- $t_i$  – running time of the event  $i$  [h],
- $R$  – order period [h].

According to [117] the expected number of failures can be determined using the following Equation:

$$H^W(t|\beta_w, \eta) = N_u \cdot F(t|\beta_w, \eta) = N_u \cdot \left(1 - e^{-\left(\frac{t}{\eta_w}\right)^{\beta_w}}\right) \quad (36)$$

Equation 37 should be used to determine the expected number of failures in the analysed period if PLP is used [157]. This Equation is used to calculate the spare parts required for corrective maintenance, as shown on pages 74, 77 and 78:

$$H^{PLP}(t|\hat{\beta}_{PLP}, \hat{\theta}) = \int_0^t \hat{u}(t) dt \quad (37)$$

Taking into account the confidence estimators  $II_1$  and  $II_2$  (according to Equations 32 and 33) the number of failures in the order period  $t$  calculated using the PLP method is expressed with a confidence interval, which is defined as follows:



$$H_L^{PLP}(t|\hat{\beta}_{PLP}, \hat{\theta}) = \int_0^{t_R} \frac{\hat{u}}{\Pi_2} dt \quad (38)$$

$$H_U^{PLP}(t|\hat{\beta}_{PLP}, \hat{\theta}) = \int_0^{t_R} \frac{\hat{u}}{\Pi_1} dt \quad (39)$$

$$CI(t|\hat{\beta}_{PLP}, \hat{\theta}) = \left[ H_L^{PLP}(t|\hat{\beta}_{PLP}, \hat{\theta}), H_U^{PLP}(t|\hat{\beta}_{PLP}, \hat{\theta}) \right] \quad (40)$$

Equations 38, 39 and 40 are used on page 74 for calculation of spare parts needed for corrective maintenance. If it is assumed that each corrective maintenance requires a number of spare parts, then it can be assumed that the number of spare parts  $N_{CM}(t)$  required for corrective maintenance in a period is directly equal to the calculated number of failures in that period and that following is valid:

$$N_{CM}(t|\hat{\beta}_{PLP}, \hat{\theta}) = \text{int} \left[ H^{PLP}(t|\hat{\beta}_{PLP}, \hat{\theta}) \right]; N_{CM}(t|\hat{\beta}_{PLP}, \hat{\theta}) \geq H^{PLP}(t|\hat{\beta}_{PLP}, \hat{\theta}) \quad (41)$$

It should be noted that the quantity of spare parts is always an integer, therefore, number of spare parts  $N_{CM}(t)$  required for corrective maintenance if equal or greater than calculated number of failures in that period.

The quantity of spare parts required for planned maintenance  $N_{PM}(t)$  in a period  $t$  can easily be determined from the CMMS by consulting the database. If the data is properly adjusted and optimized (one planned maintenance per cycle, evenly distributed over the PM interval), the quantity is equal [159]:

$$N_{PM}(T, t_R) = \text{int} \left( N_u \cdot \frac{t_R}{T} \right); N_{PM} \geq N_u \cdot \frac{t_R}{T} \quad (42)$$

where:

$N_u$  – number of units (components),

$T$  – planned maintenance interval, can be calendar or running hours,

$t_R$  – the order period.

The total spare parts quantity in the order period can be defined as a sum of total number of spare parts for planned maintenance and total number of spare parts for corrective maintenance in a period  $t_R$  [62]:

$$N_{Tot}(T, t_R) = N_{CM}(T, t_R) + N_{PM}(T, t_R) \quad (43)$$

where:

$N_{Tot}(T, t_R)$  – total number of spare parts for the order period in a period  $t_R$ ,

$N_{CM}(T, t_R)$  – total number of spare parts for corrective maintenance in a period  $t_R$ ,

$N_{PM}(T, t_R)$  – total number of spare parts for planned maintenance in a period  $t_R$ .

### 3.3.2. Planned Maintenance schedule analysis using PLP

The adjustment of planned maintenance based on a desired reliability setting can be calculated with PLP using Equation 44 [160]:

$$R(t | \hat{\beta}_{PLP}, \hat{\theta}) = \exp\left(-\frac{t}{\hat{\theta}}\right)^{\hat{\beta}_{PLP}} \quad (44)$$

The optimal planned maintenance interval per desired reliability can be calculated by Equation 45 which is which is derived from the previous Equation:

$$T(t | \hat{\beta}_{PLP}, \hat{\theta}) = \hat{\theta} \cdot \hat{\beta}_{PLP} \sqrt{\ln[1 - R_D]} \quad [\text{h}] \quad (45)$$

where:

$R_D$  – desired reliability.

The optimal planned maintenance is usually calculated for different reliability values depending on the importance of the analysed equipment and configuration of the analysed system. Equation 45 is used in this research to calculate values of the planned maintenance interval shown in Tables 5, 8 and 11.

### 3.4. THE ANALYSED EQUIPMENT

The equipment described in this Section is analysed using data from CMMS from real ships and attempts to replicate actual maintenance and usage conditions. The analysed equipment are fuel valves of the main propulsion engine. The propulsion system analysed is a classic design with a two-stroke, six-cylinder engine as the propulsion source (data withdrawn for confidentiality reasons). The components analysed are fuel valves similar to the one shown in Figure 19., where the entire valve and its components can be seen.

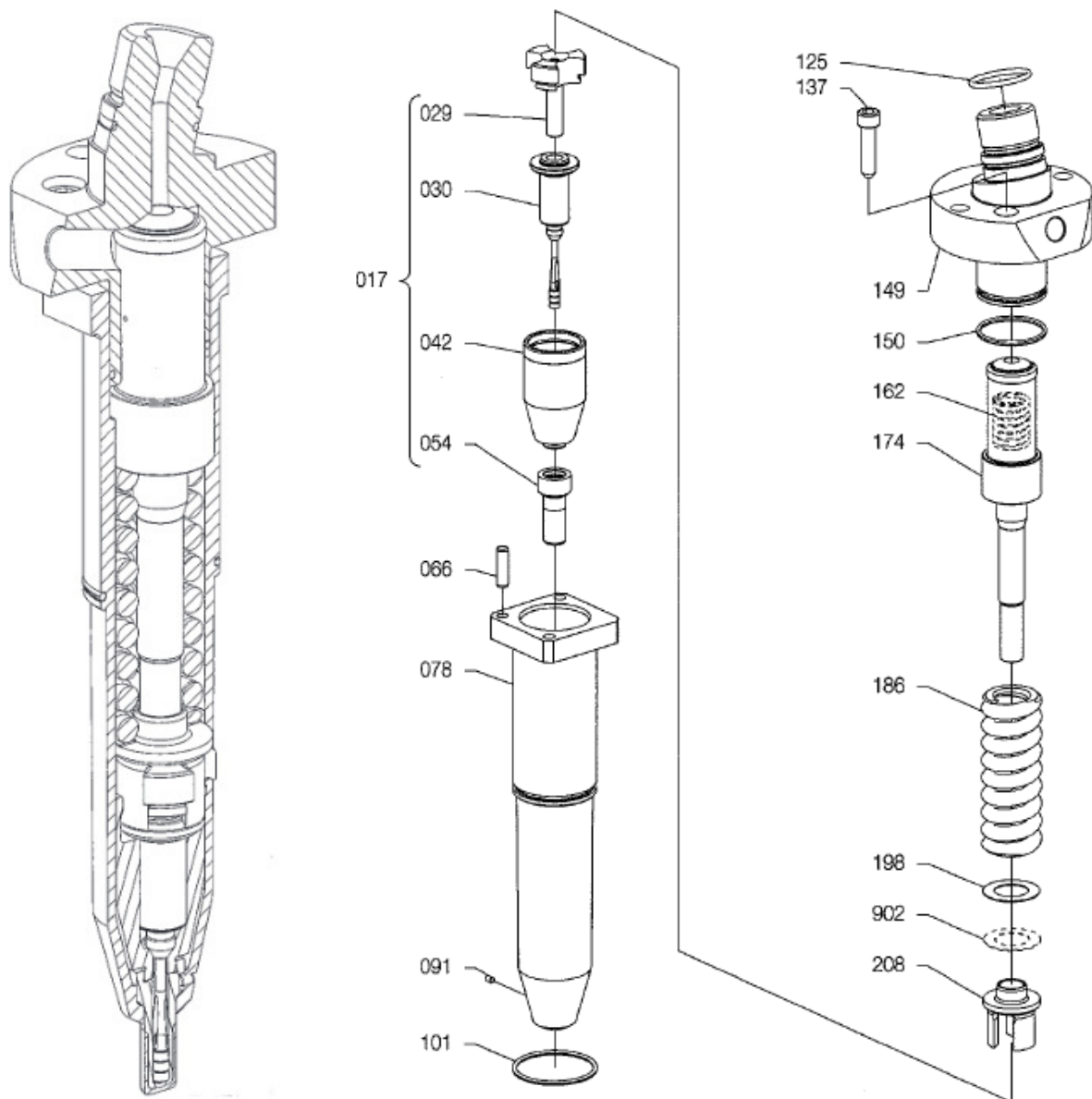

**Figure 19. MAN B&W fuel injector [161]**

The maintenance schedule taken from the CMMS is drawn up on the basis of the work description and schedule in the manufacturer's manual. Table 2. shows the maintenance schedule for fuel valves taken from the CMMS.

**Table 2. Fuel valves maintenance plan**

Name	Period	Description
Fuel valve check	4000 hrs	Perform Fuel valve check. Remove fuel valve from the engine and clean it from the outside. Test: Flushing and jet control, Opening pressure, adjust as needed, Sealing test and sliding function, Pressure test, O-ring sealing.
Fuel valve overhaul	16000 hrs	Perform Fuel valve overhaul job. Remove fuel valve from engine, disassemble, clean, replace parts as necessary, check and assemble before testing. Overhaul: Fuel valve non return valve. For details see Working Card. Renew: Fuel valve nozzle, For details see Working Card. Spindle guide. For details see Working Card. Test: Flushing and jet control, Opening pressure, adjust as needed, Sealing test and sliding function, Pressure test, O-ring sealing. For details see Working Card.

A spare parts kit containing the following parts is required to overhaul the fuel valve (the last three digits of the code correspond to the numbers shown in Figure 19.):

- sealing ring,
- sealing ring,
- sealing ring,
- spindle guide, complete,
- fuel nozzle.

The spare parts mentioned above are required for the maintenance of the fuel valves and should be available on board in sufficient (or rather appropriate) quantities, both for preventive and corrective maintenance. This spare parts kit is considered as a main unit (indivisible) for the calculation of spare parts in the model.

### 3.5. MODEL DESCRIPTION

The model for the optimization of maintenance and spare parts is developed on the basis of Table 2. The main objective of the optimization is to determine the optimal preventive maintenance period and the optimal quantity of spare parts in order to minimize the total cost per unit of time. The analysed system is subject to random failure and is analysed as a black box. Failure processes are considered as two-stage, i.e. the system can only assume two states, functioning or failed, and no further information about condition of the system is available. The optimization of maintenance and spare parts is carried out under a finite horizon.

From the analysis of the equipment and Table 2. it can be concluded that there should be three different types of maintenance in the model. These are:

- corrective maintenance, as a countermeasure to random failures,
- minor preventive maintenance,
- major preventive maintenance.

These three different types of maintenance activities are described in detail by Carlo and Arleo [162]. According to those authors, the schedule for corrective maintenance is unpredictable because the failure time of a component is not known, and the main purpose of this type of maintenance is to restore the system to a working condition [162].

The actual equipment for this model, the fuel valves, experience random failures during the operation of the system (main propulsion engine), which often lead to breakdowns and delays. To minimize these consequences, corrective maintenance is usually performed on board ships to fix a failure with minimal effort [163] and reduce stoppage and delays. In his book, Adolfo Crespo Márquez describes this minimal repair as a measure “*which will take the equipment back to operation but without restoring its failure rate*” [164].

Taking into account the actual repair conditions and the theoretical approach mentioned above, in this model all corrective maintenance actions are considered as minimum repairs that restore the equipment to operating condition without affecting its failure rate (ABAO). Since the equipment is monitored online, failures are detected immediately and all corrective maintenance actions are carried out immediately after the failure (without delay).

All figures shown in chapter 3.5 show the maintenance from Table 2, and the PLP MLE values of ship 1 calculated on page 83 were used as reference values.

Figure 20. shows how random failures are treated in the model, where function intensity is calculated according to Equation 18. The number of random failures is shown in the figure (in this case two), the time of the failures is chosen randomly. The function intensity increases in the analysed interval from 0. A failure occurs at time  $t_{f-I}$ .

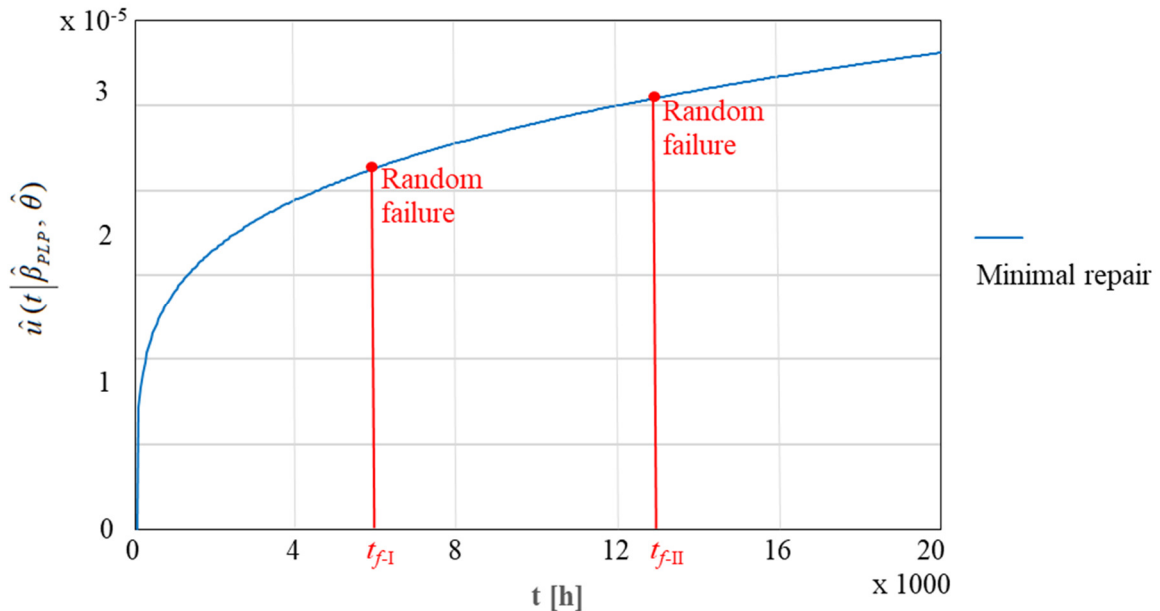
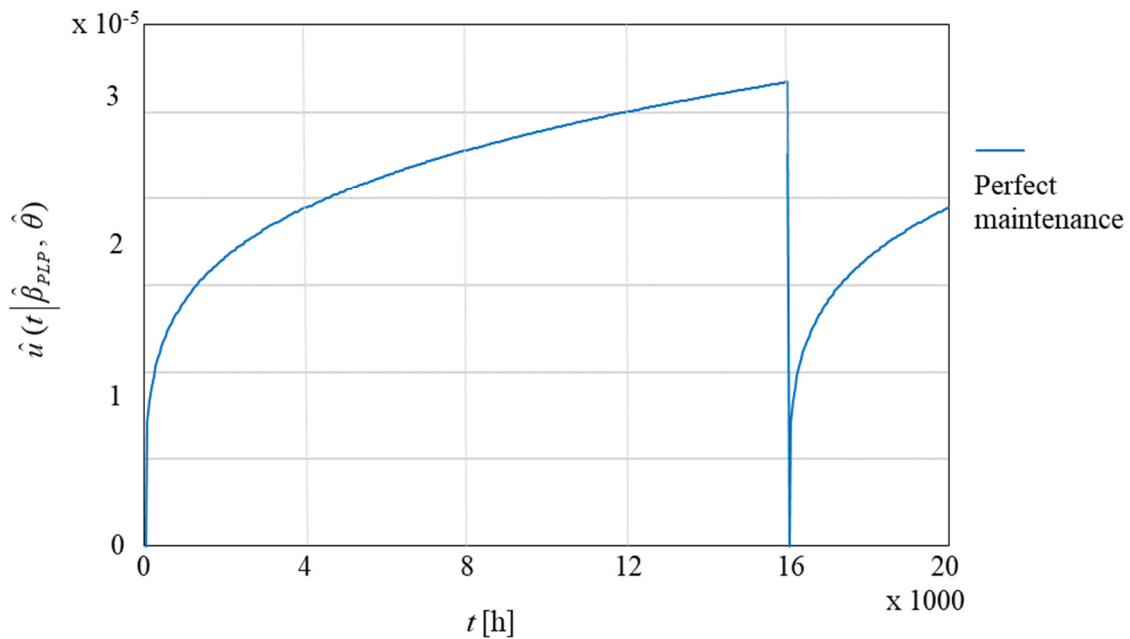

**Figure 20. Minimal repair after failure**

Since this model ignores the time required for failure detection, preparation for repair and the repair itself, the time of failure also represents the time at which all these processes take place and the time at which operation continues, i.e. when the equipment returns to the operating state. It can be seen in the figure that the intensity function has not changed, but that the curve has continued at the same point where it was. Everything shown in this figure corresponds to the above definition of minimum repair after failure, i.e. the repair returns the system to the state it was in before the failure.

In Figure 20., another random failure at time  $t_{f-II}$ , is marked and everything that applied to the first failure also applies in this case, which also applies to all subsequent failures.

Table 2. shows the planned major overhaul of the fuel valve, which includes a detailed inspection of the equipment and the replacement (renewal) of many important parts. These major overhauls with the renewal of many parts significantly improve the condition of the system and are often referred to as perfect maintenance [162 – 166]. Perfect maintenance is a repair measure that restores a system to AGAN condition and is often referred to as renewal [165, 166]. Figure 21. shows the case of a perfect repair.

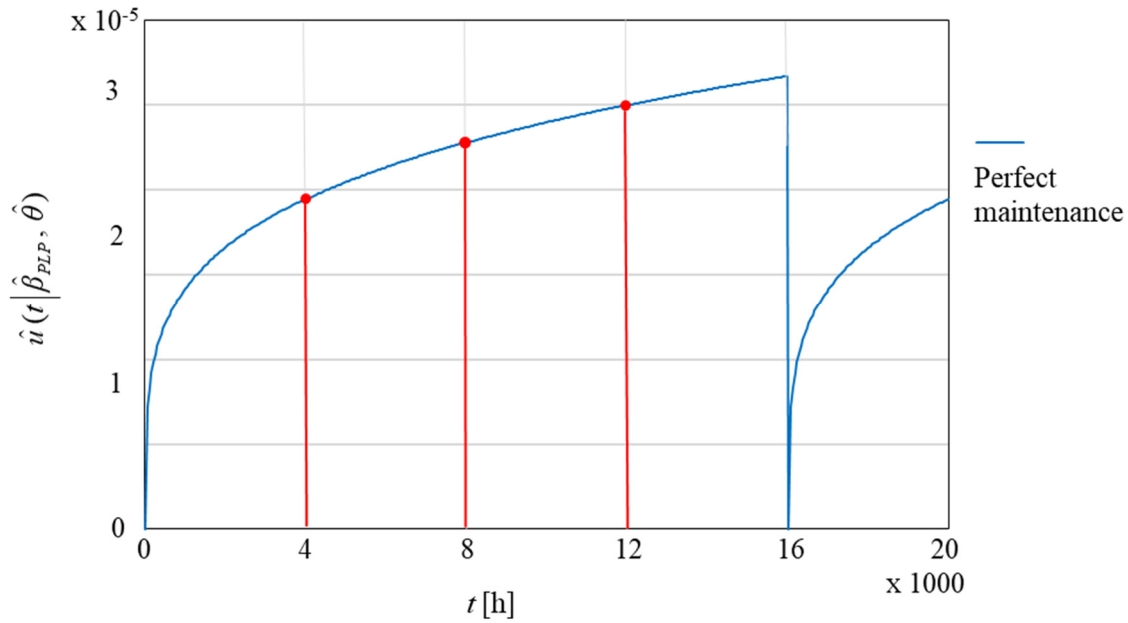

**Figure 21. Perfect maintenance at 16000 hours of operation**

The curve of function intensity is calculated using Equation 13 and in this figure is identical to the curve in Figure 20. up to the time of the major overhaul, which is scheduled for 16000 hours. At this point, the state of the equipment returns to AGAN.

Another preventive maintenance in Table 2. is the fuel valve check, which the manufacturer recommends to be carried out every 4000 hours. This term was interpreted at the beginning of the research as a simple check or inspection of the unit. During the literature review on this topic, it was found that Ahmadi et al. in their model said that “*repair due to failures found by inspection is considered as minimal repair*” [167]. Following this approach, maintenance at 4000 hours was considered minimal at the beginning of this research, i.e. the intensity function will not change after this maintenance, the function intensity curve will continue at the same point where it was before.

This maintenance approach is illustrated in Figure 22. The function intensity (the same as in Figure 21.) increases over time up to 4000 hours when the first check is carried out. The time required for the check has been ignored and the time of the check is the time at which operation continues without any change in the function intensity. The same applies to all further checks. The maintenance costs for the checks are included in the preventive maintenance costs, as are all spare parts required for preventive maintenance.



**Figure 22. Maintenance model at the beginning of the research**

Continuation of the research brought the realization that although equipment manufacturers refer to this work as a "check", it is much more than that. This work requires disassembly, cleaning, testing and adjustment of the equipment, sometimes replacement of spare parts. An important insight provided Malik who wrote as an example: “*Cleaning of Diesel fuel injectors improves performance. Adjustment through a spring restores them to their near original state*” [168]. Therefore, this work is referred to in this thesis as a "minor overhaul". From the work described Table 2. It can be concluded that the equipment is in better condition after the minor overhaul than before. As this is not a major replacement of parts, but only a minor intervention, the condition of the equipment after the intervention will not be AGAN. Accordingly, the condition of the equipment after the repair will be somewhere between AGAN and ABAO. The repair that returns the equipment to this state is called imperfect maintenance. Carlo and Arleo [162] describe this type of maintenance as an action that returns the condition of the system to a younger state (somewhere between AGAN and ABAO). Zhang and Jardine describe imperfect maintenance as an action “*that make a system “better than old” but not AGAN*” [163], similar to the description by Ben-Daya et al. [165].

There are several methods for modelling imperfect maintenance, which are summarised in [108, 162] and are divided into the following:

- The  $(p, q)$  rule method, first published by Chan [169] and Nakagawa [170, 171], where  $p$  is the probability that the unit will return to the AGAN state and  $q$  is the probability that the unit will return to the ABAO state, where  $q = 1 - p$ .



- The  $[p(t), q(t)]$  rule method, presented by Block et al. [172] is an age-dependent imperfect method, where  $p(t)$  is the probability that the unit returns to the AGAN state and  $q(t)$  is the probability that the unit returns to the AGAN state, and  $t$  is the time since the last perfect repair.
- The improvement factor method presented by Malik [168] introduces a factor into maintenance scheduling that changes the system time of the failure rate curve to a more recent time, but not quite to zero.
- The virtual age method, first published by Kijima et al. [173], introduces the idea of virtual age process of a repairable system.
- The shock model method, first explored by Bhattacharjee [174], in which the unit suffers non-negative random damage and the system fails when the damage exceeds a predetermined level.
- The  $(\alpha, \beta)$  rule method, also called quasi-renewal method, introduced by Yeh [175], later researched by Wang and Pham [176-178], in which imperfect repairs lead to a reduction in the lifetime of a system to a fraction of the previous lifetime, i.e. the lifetime decreases with the number of repairs. In this method,  $\alpha$  is a lifetime reduction factor and  $\beta$  is an incremental factor for the repair time.
- The multiple  $(p, q)$  rule method presented by Shaked and Shanthikumar [179] considers the concept of multivariate imperfect repair, i.e. a system with components that have dependent lifetimes and are repaired with imperfect repair based on the  $(p, q)$  rule.
- The hybrid model method proposed by Lin et al. [180] combines two models, namely the hazard rate PM model and the age reduction PM model.

The imperfect maintenance modelling in this thesis uses a method introduced by Nakagawa [87, 181], in which the failure rate after the  $k^{\text{th}}$  PM becomes  $a_k$  multiplied with  $h(t)$ , where  $h(t)$  is calculated for the period  $k-1$  and  $a_k \geq 1$ . This calculation ensures that the failure rate increases with the number of PMs. This method was later explored by Usher [182], Crespo [164] and Gertsbach [183], who referred to it as the “partial renewal model”.

Gertsbach [183] introduced a specific degradation factor in his calculation and stated that one of the main characteristics of imperfect maintenance is that “*the mean number of failures on the interval  $I_K$  after a partial renewal carried out at the instant  $T_{K-1}$  equals the mean number of failures on the interval  $I_{K-1}$  multiplied by the degradation factor  $e^\alpha$* ”.

Figure 23. shows the principle of imperfect maintenance using the mean failure time  $H(t|\hat{\beta}_{PLP}, \hat{\theta})$  calculated for three variants for data from Table 2 and failure data for ship 1. The first variant is shown with a dashed line, where each minor overhaul is calculated as a minimal repair, i.e. it does not change the mean failure time (repair is considered as ABAO), but the curve continues to grow as before the overhaul. The diagram in Figure 23 is calculated using the Equation 37. For no PM line, the equation is calculated without changes, while for other two is calculated in a way that the system failure rate at each interval of 4000 hours is equal to the system failure rate on the previous interval  $I_{k-1}$  multiplied by a "degradation" factor  $e^\alpha$ . In this calculation, coefficient  $\alpha$  has the value of 0.1. The line of the perfect PM is calculated in the same way, with  $\alpha = 0$ .

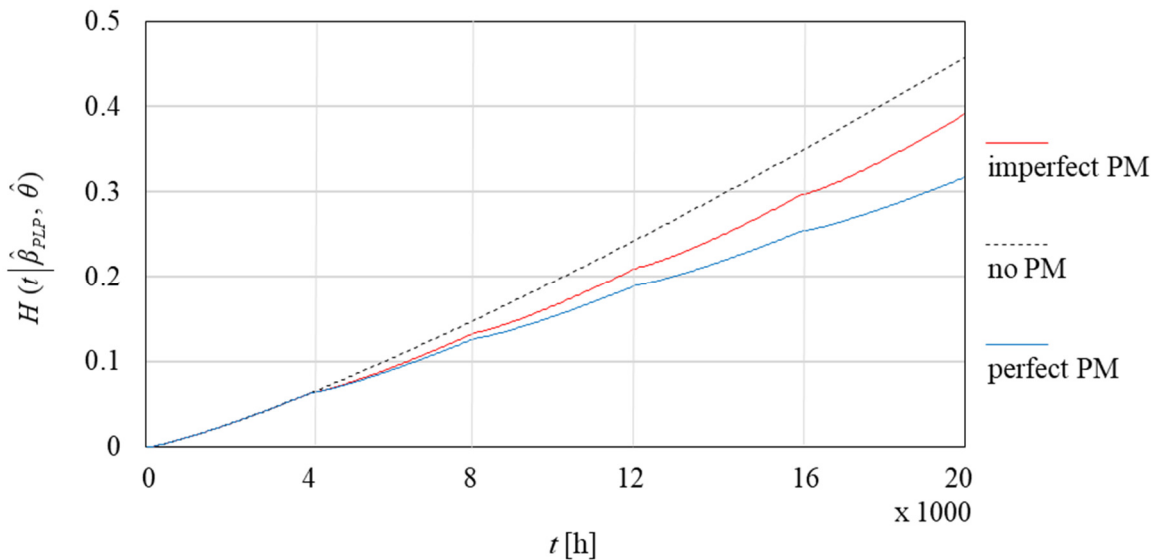

**Figure 23. The influence of the maintenance types on mean number of failures**

The second, blue line represents the mean failure time, which is calculated in such a way that every minor overhaul is considered perfect maintenance, which reduces the function intensity to zero. In the first period of 4000 hours, the blue curve and the dashed curve coincide completely. The difference starts after the first minor overhaul at 4000 hours, and from this point onwards a clear change in the blue curve can be seen every 4000 hours (after each minor overhaul). As can be seen in the figure, the blue curve grows more slowly than the dashed curve, and the growth rate of the blue curve decreases after each minor overhaul. The dashed line and the blue line represent the boundaries within which the third line is located. The red line in the figure represents the mean number of failures calculated so that any minor overhaul is considered imperfect maintenance, i.e. that the repair itself is not AGAN or ABAO, but somewhere in between. And this curve coincides with the dashed and blue curves for the first

4000 hours of operation and then diverges from them. As can be seen in the figure, there is also a change in this curve every 4000 hours.

All three cases are also illustrated in Figure 24., which shows the changes in the reliability curves as a function of the type of maintenance. As in Figure 23., the curve for imperfect PM (red) lies between the curves for AGAN (blue) and ABAO (dashed). The distance between the curves in both figures increases with the number of minor overhauls carried out, i.e. it increases with time. This Figure is calculated using the data from the Figure 23 and using Equation 46:

$$R(t) = \exp[-H(t)] \quad (46)$$

where:

$H(t)$  – mean number of failures calculated as described per Figure 23.

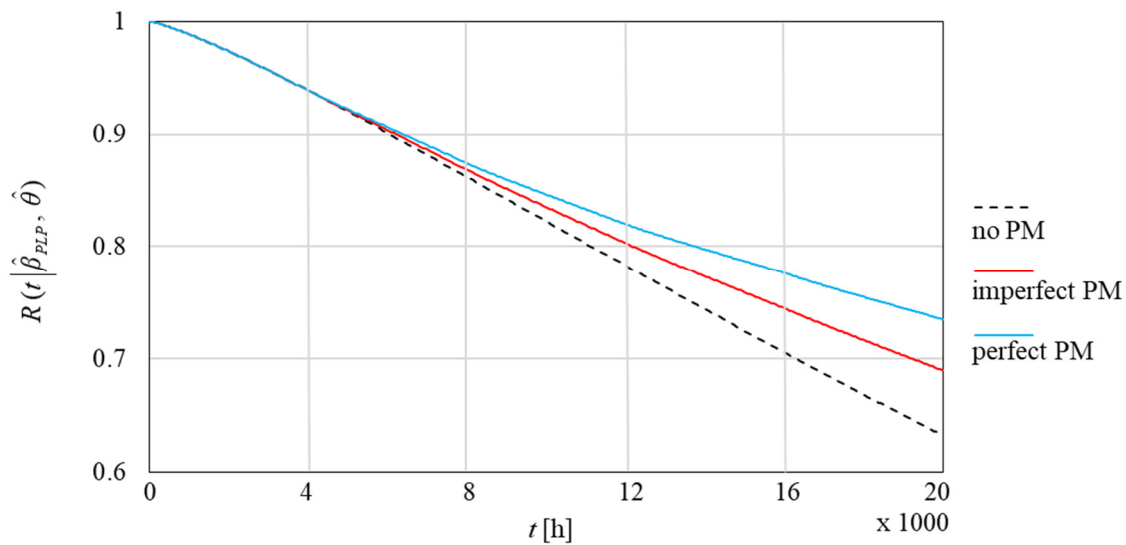

**Figure 24. The influence of the maintenance types on reliability**

The influence of imperfect PM, which is carried out every 4000 working hours, on function intensity is shown in Figure 25. There you can see that the curve falls, but that it does not fall to zero, but stops somewhat higher. The figure shows that the deviation from zero increases with each minor overhaul. After the first imperfect maintenance, the value of function intensity  $u(t | \hat{\beta}_{PLP}, \hat{\theta}) = 3.242 \times 10^{-6}$ . This value increases after each subsequent intervention and after the fourth imperfect maintenance the value is  $u(t | \hat{\beta}_{PLP}, \hat{\theta}) = 4.377 \times 10^{-6}$ .

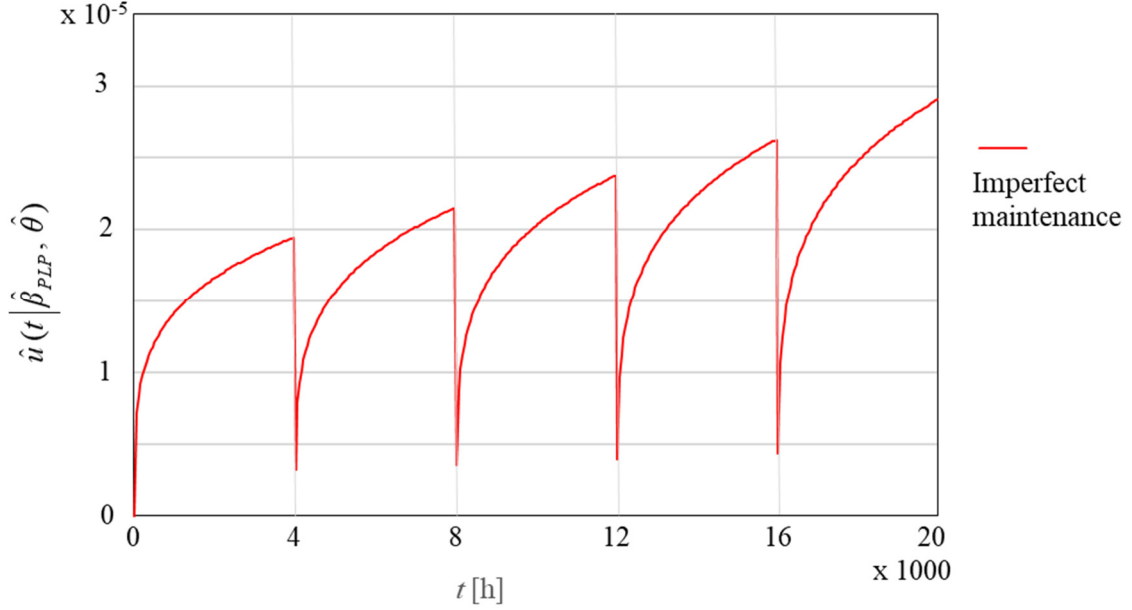

**Figure 25. Imperfect maintenance**

Figures 20., 21. and 25. shows the principles of all the maintenance actions described in the model. The system has three types of maintenance actions, namely minimal repairs, minor overhauls and major overhauls with renewals. After each failure, there is a minimal repair that restores the system to its pre-failure condition. The system is completely overhauled when it has reached a certain number of hours after the last major overhaul, which brings it in a condition AGAN. The period between two successive major overhauls is divided into  $K$  periods of equal length, in which  $K-1$  minor overhauls are carried out, returning the system to a “better than old” but not AGAN condition.

Maintenance costs in this case are [164, 268]:

$$C_M = \frac{C_{CM} \cdot H(T) \cdot (1 + e^\alpha + \dots + e^{\alpha(K-1)}) + C_{PMi} (K-1) + C_{PMp}}{\sum_{i=1}^K T_i} \quad (47)$$

where:

$C_M$  – maintenance costs,

$C_{CM}$  – the costs of the corrective maintenance,

$e^\alpha$  – degradation factor,

$T$  – planned maintenance interval (duration of minor overhaul cycle),

$H(T)$  – number of failures in interval  $T$ ,

$K$  – number of overhaul periods in main overhaul time,

$C_{PMi}$  – costs of imperfect minor overhaul,

$C_{PMp}$  – costs of a main overhaul.

Figure 26. shows function diagram, calculated according to Equation 47. The intensity increases from beginning of the process till the end of period  $K_1$  (period of  $T = 4000$  running hours), when a minor, imperfect overhaul is carried out, which reduces the intensity but does not bring it back to an AGAN level. In period  $K_2$ , the intensity increases with the function intensity of the previous interval, multiplied by the degradation factor  $e^\alpha$ . After three minor imperfect overhauls, a major overhaul is performed, which brings the intensity back to 0. The Figure 26. also shows two random failures that happen at times  $t_{f-I}$  and  $t_{f-II}$ . After the failures, a where minimal repair was applied, which returned the system to the state it was in before the failure (ABAO).

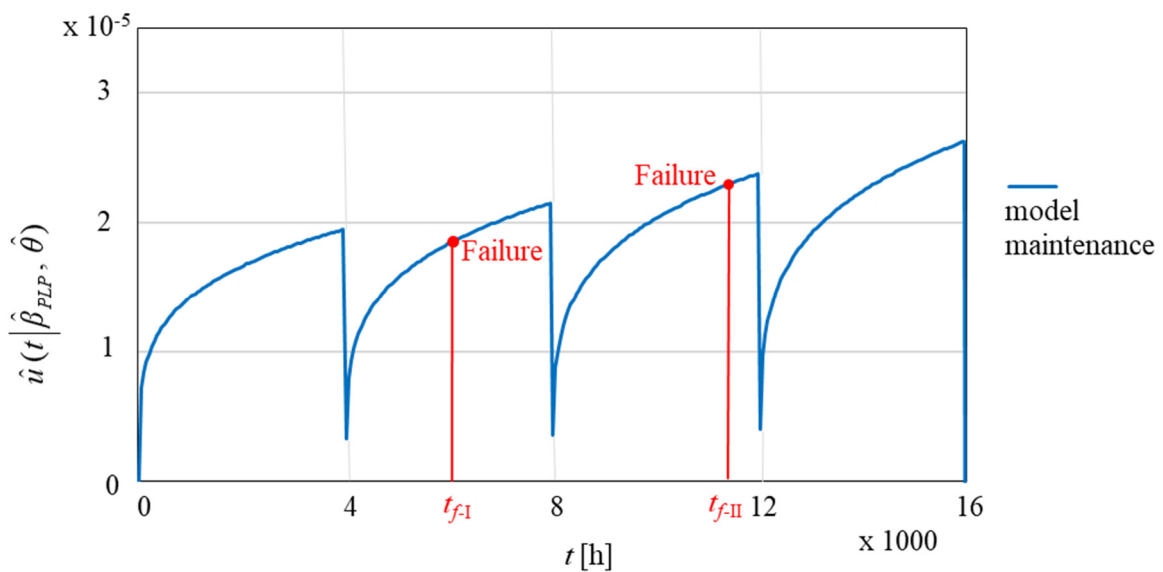

**Figure 26. Function intensity in the model**

All assumptions included in the model can be summarized to a list, some of these items are already explained above:

- Personnel required for maintenance operations are always available.
- Personnel working time is not subjected to any restrictions (0 – 24).
- The consumables required for maintenance are always available.
- The time required for maintenance operations is considered irrelevant and ignored.
- As the system is monitored online, the failure detection is immediate and all corrective maintenance actions are performed immediately after the failure.
- Spare parts kit specified in 3.4. is assumed as spare parts unit in the model.
- Corrective maintenance is considered a minimal repair, which will restore equipment to operation, without restoring its failure rate.

- Minor overhaul is considered as an imperfect maintenance, restoring the failure rate of the equipment to a point between AGAN and ABAO.
- Minor overhaul is carried out at fixed time  $T_G$  ( $G=1, 2, \dots, K-1$ ),  $T_G$  is fixed value of the duration of the interval  $K$ .
- Major overhaul is carried out after  $K$  intervals and  $K - 1$  minor overhauls, restoring the failure rate of the equipment to condition AGAN.
- $\lambda(t)$  is continuous and increasing with time.

This model (presented in Figure 26.) intends to determine optimal overhaul time  $T^*$ , optimal spare parts order size  $N^*$  and the number of minor overhauls ( $K-1$ ) which will produce minimal maintenance costs.

### 3.6. OPTIMIZATION EQUATION

Optimization Equation for this model is derived from the equation for maintenance and spare parts costs [63, 64, 102, 184]:

$$C_{Tot} = C_M + C_S \quad (48)$$

where:

$C_{Tot}$  – total costs of the maintenance and spare parts,  
 $C_M$  – maintenance costs,  
 $C_S$  – spare parts costs.

The first part of Equation 48 is defined by Equation 47, which is to be extended in this model. The first part of Equation 47 is the cost of corrective maintenance for  $C_{CM}$ , which can be described in detail as follows:

$$C_{CM} = C_{CMW} + C_{CMI} + C_{CMC} + C_{CME} \quad (49)$$

where:

$C_{CMW}$  – work force costs of corrective action,  
 $C_{CMI}$  – indirect internal costs of corrective maintenance (stoppage costs, failure costs, costs of damage to other equipment, etc.),  
 $C_{CMC}$  – consumption materials costs of corrective maintenance,  
 $C_{CME}$  – external costs of corrective maintenance (damage to ship and cargo, persons, environment, etc.).

The work force cost for corrective action is the product of the labour costs, the number of people who performed the work and the number of hours worked. The equation for corrective labour cost is [61]:

$$C_{CMW} = C_{MH} \cdot W \cdot h_{CM} \quad (50)$$

where:

$C_{MH}$  – work force hourly costs,  
 $W$  – number of persons performing the task,  
 $h_{CM}$  – number of hours needed to perform corrective action.

The indirect internal cost of a corrective action depends on stoppage hourly costs, component failure costs and costs of damage to other equipment (based on [61]):

$$C_{CMi} = C_{Stp} \cdot h_{CM} + C_{Fai} + C_{Dam} \quad (51)$$

where:

$C_{Stp}$  – stoppage hourly costs,  
 $C_{Fai}$  – component failure costs,  
 $C_{Dam}$  – costs of damage to other equipment.

Therefore, in Equation 47, the cost of corrective maintenance can be replaced by a more detailed expression (the complete one):

$$C_{CM} = \underbrace{(C_{MH} \cdot W \cdot h_{CM})}_{C_{CMW}} + \underbrace{(C_{Stp} \cdot h_{CM} + C_{Fai} + C_{Dam})}_{C_{CMi}} + C_{CMC} + C_{CME} \quad (52)$$

The next element in Equation 47 is the degradation factor by which the cost of corrective maintenance is multiplied. It can be expressed as follows [183]:

$$(1 + e^\alpha + \dots + e^{\alpha(K-1)}) = \frac{(e^{\alpha K} - 1)}{(e^\alpha - 1)} \quad (53)$$

The cost of a minor, imperfect overhaul  $C_{PMi}$  is the next item in Equation 47. This cost is the sum of the labour cost of a minor overhaul, the indirect internal cost of a minor overhaul and the cost of consumables for a minor overhaul [61]. Equations 54 and 55, that show this breakdown, are modified equations published by Franciosi et al. [61]:

$$C_{PMi} = C_{PMiW} + C_{PMiI} + C_{PMiC} \quad (54)$$

where:

$C_{PMiW}$  – work force costs of a minor, imperfect overhaul,  
 $C_{PMiI}$  – the indirect internal costs of a minor, imperfect overhaul (stoppage , etc.),  
 $C_{PMiC}$  – cost of consumables for a minor, imperfect overhaul.

The work force cost of a minor, imperfect overhaul is the product of the work force cost, the number of people who performed the work, and the number of hours worked [61]:

$$C_{PMiW} = C_{MH} \cdot W \cdot h_{PMi} \quad (55)$$

where:

$C_{MH}$  – work force hourly costs,  
 $W$  – number of persons performing the task,  
 $h_{PMi}$  – number of hours needed to perform a minor overhaul.

The indirect internal cost of a minor imperfect overhaul depends on the stoppage cost per hour (based on [61]) and the number of stoppage hours:

$$C_{PMiI} = C_{Stp} \cdot h_{PMi} \cdot P_{PMi} \quad (56)$$

where:

$C_{Stp}$  – stoppage hourly costs,  
 $h_{PMi}$  – number of hours needed to perform a minor overhaul,  
 $P_{PMi}$  – probability that the stoppage costs for a minor overhaul will be incurred.



The cost of preventive maintenance for a minor imperfect overhaul in Equation 47 can be replaced by a more detailed expression:

$$C_{PMi} = \underbrace{C_{MH} \cdot W \cdot h_{PMi}}_{C_{PMiW}} + \underbrace{C_{Sp} \cdot h_{PMi} \cdot P_{PMi}}_{C_{PMiI}} + C_{PMiC} \quad (57)$$

The last item to be analysed and expanded from Equation 47 is the cost of a major perfect overhaul  $C_{PMp}$ . This cost is the sum of the labour cost of a major perfect overhaul, the indirect internal cost of a major overhaul and the cost of consumables for a major overhaul:

$$C_{PMp} = C_{PMpW} + C_{PMpI} + C_{PMpC} \quad (58)$$

where:

$C_{PMpW}$  – work force costs for a major, perfect overhaul,  
 $C_{PMpI}$  – the indirect internal costs of a major overhaul (stoppage , etc.),  
 $C_{PMpC}$  – cost of consumables for a major overhaul.

The work force cost of a major perfect overhaul is the product of the work force cost, the number of people who carried out the work and the number of hours worked, exactly as already shown for the minor imperfect overhaul [61]:

$$C_{PMpW} = C_{MH} \cdot W \cdot h_{PMp} \quad (59)$$

where:

$C_{MH}$  – work force hourly costs,  
 $W$  – number of persons performing the task,  
 $h_{PMp}$  – number of hours needed to perform a major overhaul.

The indirect internal cost of a minor imperfect overhaul depends on the stoppage cost per hour (based on [61]) and the number of stoppage hours:

$$C_{PMpI} = C_{Sp} \cdot h_{PMp} \cdot P_{PMp} \quad (60)$$

where:

$C_{Sp}$  – stoppage hourly costs,  
 $h_{PMp}$  – number of hours needed to perform a major overhaul,  
 $P_{PMp}$  – probability that the stoppage costs for a major overhaul will be incurred.

The cost of preventive maintenance for a major perfect overhaul in Equation 47 can be replaced by a more detailed expression:

$$C_{PMp} = \underbrace{C_{MH} \cdot W \cdot h_{PMp}}_{C_{PMpW}} + \underbrace{C_{Sip} \cdot h_{PMp} \cdot P_{PMp}}_{C_{PMpl}} + C_{PMpC} \quad (61)$$

According to [102, 184], the cost of corrective maintenance and the cost of preventive maintenance in the system can be expressed as the cost of one action multiplied by the number of units  $N_u$ . By extending Equation 47 with all the additions listed, a new Equation for maintenance costs is created:

$$C_M = \frac{N_u}{\sum_{i=1}^K T_i} \cdot \left\{ \begin{aligned} & \left[ (C_{MH} \cdot W \cdot h_{CM}) + (C_{Sip} \cdot h_{CM} + C_{Fai} + C_{Dam}) + C_{CMC} + C_{CME} \right] \cdot \\ & \cdot H(T) \cdot \frac{(e^{aK} - 1)}{(e^a - 1)} + \\ & + \left[ (C_{MH} \cdot W \cdot h_{PMi}) + (C_{Sip} \cdot h_{PMi} \cdot P_{PMi}) + C_{PMiC} \right] (K-1) + \\ & + \left[ (C_{MH} \cdot W \cdot h_{PMp}) + (C_{Sip} \cdot h_{PMp} \cdot P_{PMp}) + C_{PMpC} \right] \end{aligned} \right\} \quad (62)$$

In order to organize successful maintenance, a sufficient quantity of spare parts is required [60, 61, 81, 86, 98, 102, 109, 114 124, 184, 185]. If this statement is accepted as fact, then Equation 63 (similar to and derived from Equation 47) is valid:

$$N_T = \frac{N_{CM} + N_{PMi} (K-1) + N_{PMp}}{\sum_{i=1}^K T_i} \quad (63)$$

where:

$N_T$  – total number of spare parts for the period,

$N_{CM}$  – quantity of spare parts required for corrective maintenance,

$K$  – number of overhaul periods in the main overhaul time,

$N_{PMi}$  – quantity of spare parts required for the imperfect minor overhaul,

$N_{PMp}$  – quantity of spare parts required for the major overhaul.

The quantity of spare parts required for corrective maintenance is calculated according to Equation 64 where  $H(t)$  is calculated as per degradation shown in Equation 47.

$$N_{CM} \geq H(t) = \text{int} \left( \frac{H(T) \cdot (e^{\alpha K} - 1)}{(e^{\alpha} - 1)} \right) \quad (64)$$

where:

$e^{\alpha}$  – degradation factor,

$H(T)$  – number of failures in interval  $T$ .

$H(t|\hat{\beta}, \hat{\theta})$  as a principal parameter for calculation of  $N_{CM}$  in the model is shown in Figures 27. and 28. Figure 27 shows behaviour of  $H(t|\hat{\beta}, \hat{\theta})$  for ship 1 and calculated values of  $N_{CM}$ . From the figure it is visible that value of spare parts for corrective maintenance for the interval of almost  $T= 40000$  hours will be 1.

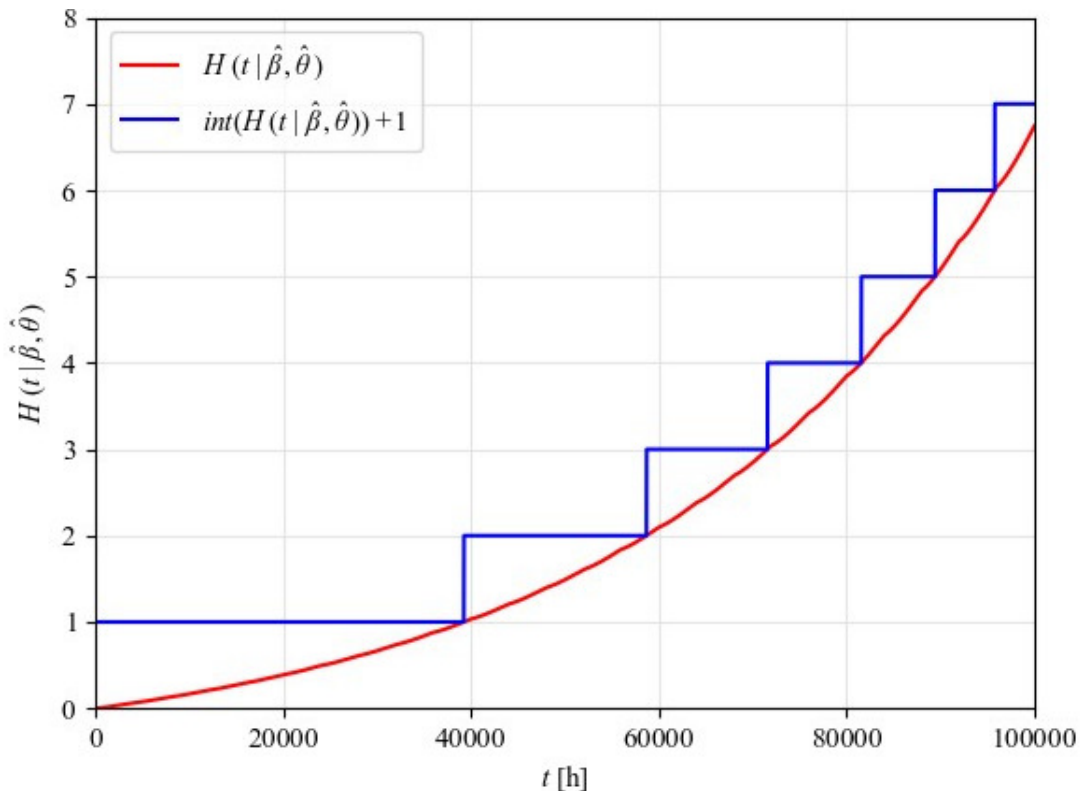

**Figure 27. Calculation of  $N_{CM}$  for ship 1**

As this figure is presenting large time span, changes in  $H(t|\hat{\beta}, \hat{\theta})$  are visible only when the figure is enlarged as shown in Figure 28.

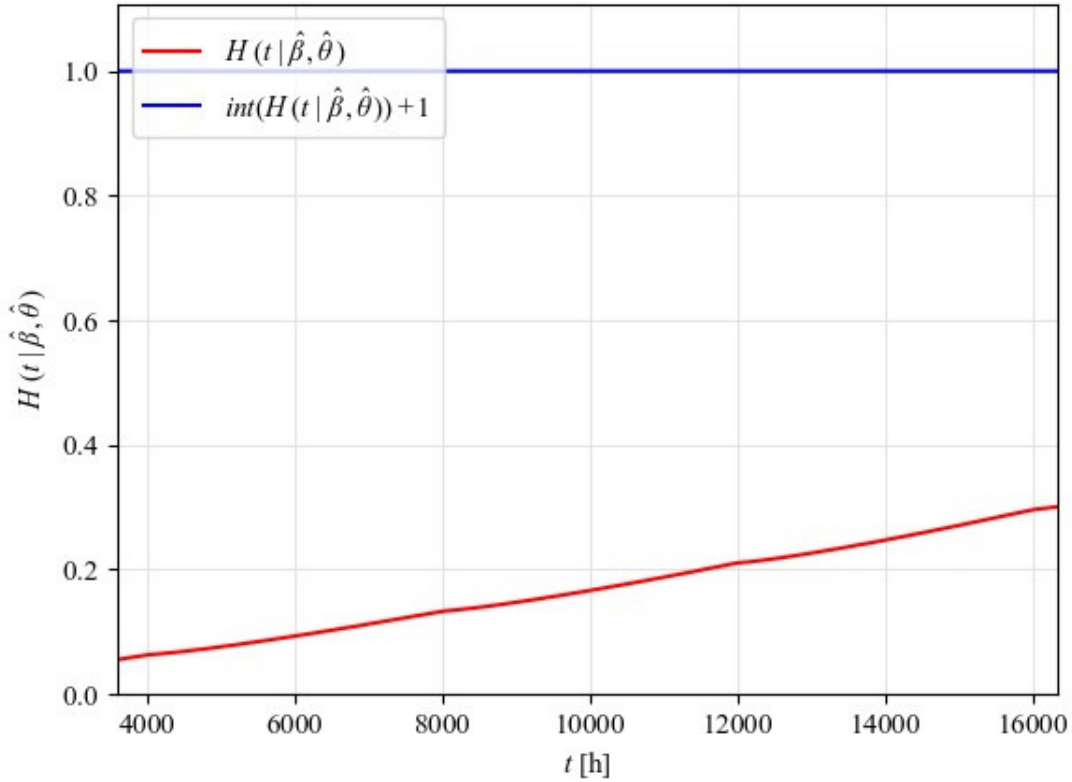

**Figure 28. Excerpt from the Figure 27.**

On the figure are visible changes in  $H(t|\hat{\beta}, \hat{\theta})$  occurring every 4000 hours, as defined in the model.

The total cost of spare parts  $C_S$  can be expressed by Equation 64 as the sum of the cost of purchasing spare parts, the delivery cost and the storage cost [58]:

$$C_S = C_{Pur} + C_{Del} + C_{Str} \quad (65)$$

where:

- $C_{Pur}$  – spare parts purchase costs,
- $C_{Del}$  – spare parts delivery costs,
- $C_{Str}$  – spare parts storage costs.

Equation 65 is used to the total cost of spare parts for this research. According to [8], page 125, the Economic Order Quantity (EOQ or  $N$ ) is determined by Equation 66:

$$N = \sqrt{\frac{2 \cdot N_T \cdot C_{Pur}}{C_{Str}}} \quad (66)$$

According to the same author [8], the average cost per unit of time is as follows:

$$C_s = \frac{N_T \cdot C_{Spa}}{N} + \left( \frac{N}{2} + S_s \right) \cdot C_{Hol} + C_{SS} \quad (67)$$

where:

$S_s$  – spare parts safety minimum quantity (Safety stock),  
 $C_{SS}$  – spare parts shortage costs.

The first part of Equation 67, which represents the purchase cost of spare parts  $C_{Pur}$ , can be divided according to Equation 63 into the purchase cost of spare parts for two types of preventive maintenance and spare parts for corrective maintenance. The combination of these equations results in [58, 98]:

$$C_{Pur} = \frac{N_T \cdot C_{Spa}}{N} = \frac{\left[ N_{CM} + N_{pi} (K-1) + N_{po} \right] \cdot C_{Spa}}{\sum_{i=1}^K T_i \cdot N} \quad (68)$$

The second part of the Equation 67 represents spare parts storage costs [58, 98, 158]:

$$C_{Str} = \left( \frac{N_e}{2} + S_s \right) \cdot C_{Hol} \quad (69)$$

where:

$C_{Spa}$  – costs of unit sizes of spare parts,  
 $C_{Hol}$  – holding costs (storage costs + degradation costs).

The third part of Equation 67 is  $C_{SS}$ , spare parts shortage costs, i.e. the cost of not having a suitable spare part. For the reasons explained in Section 2.2., these costs are missing in this model. This is the safety critical spare part minimum  $S_{CS}$  defined in Equation 3. Therefore, instead of calculating the average cost of not having a suitable spare part, a change has been made to Equation 67 and the new Equation reads:

$$C_{Str} = \left( \frac{N}{2} + S_s + S_{CS} \right) \cdot C_{Hol} \quad (70)$$

Equation 63 must also be amended to at least take into account the purchase costs for safety critical spare parts minimum:

$$N_T = \frac{N_{CM} + N_{PMi}(K-1) + N_{PMp} + S_{CS} \cdot p_c}{\sum_{i=1}^K T_i} \quad (71)$$

where:

$p_c$  – factor for dividing  $S_{CS}$  costs to multiple periods... ( $0 < p_c < 1$ ).

**Equations 70 and 71 represent insertion of the requirements of the maritime laws and regulations [132 – 135] as per facts presented in Section 2.2 and has never been used before.**

Tusar [58] described the spare part delivery costs  $C_{Del}$ , which are included in Equation 64 but are completely missing in Equation 66. These costs are the sum of all costs incurred for the transportation and handling of the spare parts as well as for customs, agents and all other related costs [8, 58, 158]:

$$C_{Del} = (C_{Han} + C_{Cus}) \cdot N_T = \frac{(C_{Han} + C_{Cus}) \cdot [N_{CM} + N_{PMi}(K-1) + N_{PMp} + S_{CS} \cdot p_c]}{\sum_{i=1}^K T_i} \quad (72)$$

where:

$C_{Han}$  – spare parts transport, handling... (most of these costs depend on the parcel size),  
 $C_{Cus}$  – customs, agent, paperwork fee, and other costs (most of these costs are fixed costs, regardless of the parcel size).

Combining all the above equations (Equations 63 to 72), the Equation for spare parts costs can be expressed as follows [8, 58, 61, 62, 98, 102, 158, 183 – 185]:

$$C_S = \frac{[N_{CM} + N_{PMi}(K-1) + N_{PMp} + S_{CS} \cdot p_c] \cdot C_{Spa}}{\sum_{i=1}^K T_i \cdot N} + \frac{(C_{Han} + C_{Cus}) \cdot [N_{CM} + N_{PMi}(K-1) + N_{PMp} + S_{CS} \cdot p_c]}{\sum_{i=1}^K T_i} + \left[ \left( \frac{N}{2} + S_S + S_{CS} \right) \cdot C_{Hol} + C_{SS} \right] \quad (73)$$

The slightly modified Equation 66 is used to calculate the EOQ (modified based on showed Equations):

$$N = \sqrt{\frac{2 \cdot N_T \cdot C_{Pur}}{C_{Str}}} = \sqrt{\frac{2 \cdot [N_{CM} + N_{PMi}(K-1) + N_{PMp} + S_{CS} \cdot p_c] \cdot C_{Pur}}{C_{Str} \cdot \sum_{i=1}^K T_i}} \quad (74)$$

The total maintenance and spare parts costs  $C_{Tot}$  can be expressed as follows:

$$C_{Tot} = C_M + C_S =$$

$$= \frac{N_u}{\sum_{i=1}^K T_i} \cdot \left\{ \begin{aligned} & \left[ (C_{MH} \cdot W \cdot h_{CM}) + (C_{Stp} \cdot h_{CM} + C_{Fai} + C_{Dam}) + C_{CMC} + C_{CME} \right] \cdot \\ & \cdot H(T) \cdot \frac{(e^{aK} - 1)}{(e^a - 1)} + \\ & + \left[ (C_{MH} \cdot W \cdot h_{PMi}) + (C_{Stp} \cdot h_{PMi} \cdot P_{PMi}) + C_{PMiC} \right] (K-1) + \\ & + \left[ (C_{MH} \cdot W \cdot h_{PMp}) + (C_{Stp} \cdot h_{PMp} \cdot P_{PMp}) + C_{PMpC} \right] \end{aligned} \right\} +$$

$$+ \frac{[N_{CM} + N_{PMi}(K-1) + N_{PMp} + S_{CS} \cdot p_c] \cdot C_{Spa}}{\sum_{i=1}^K T_i \cdot N} +$$

$$+ \frac{(C_{Han} + C_{Cus}) \cdot [N_{CM} + N_{PMi}(K-1) + N_{PMp} + S_{CS} \cdot p_c]}{\sum_{i=1}^K T_i} +$$

$$+ \left[ \left( \frac{N}{2} + S_S + S_{CS} \right) \cdot C_{Hol} + C_{SS} \right]$$

$C_S$

$C_M$

(75)

The objective function is to determine the order quantity  $N^*$  and preventive maintenance time  $T^*$  that minimize the total maintenance and spare parts cost (according to Optimization Equation 75):

$$\text{Min } C_{Tot} (N^*, T^*)$$

Equation 75 represents the final optimization expression that should be solved by an optimization method. There are a number of methods that can be used for this purpose, and one had to be selected that fits into the overall approach of solving the problem using the simplest possible method. In the remainder of this chapter, the optimization method and its creation are described.

### 3.7. OPTIMIZATION METHOD

According to Merriam Webster's dictionary, brute force is an adjective meaning “*relying on or achieved through the application of force, effort, or power in usually large amounts instead of more efficient, carefully planned, or precisely directed methods*” [186]. This phrase perfectly describes the Brute Force Method (BFM) used to solve the optimization problem. The BFM was chosen to solve the problem because it is easy to program and does not require extensive mathematical or programming knowledge, but relies on the computational power of the computer.

Applying the BFM to an optimization problem is considered a contradiction, as this method uses pure computing power and effort to solve a problem without attempting to optimize the process.

A more detailed explanation of this method can be found in Figure 29. The method begins with the programming of the BFM, whereby it is first checked which libraries (previously defined code) are required and these are imported. The next step is to define the BFM (definition of the loop that the method will follow). After this step, it is necessary to define the Equation in the program. The program immediately reports that the non-changeable values (constants), which must be present in the program, are missing. After entering the constants, the program must define the variables and set their minimum and maximum values (operating limits). Once everything is entered, the program can search for a solution.



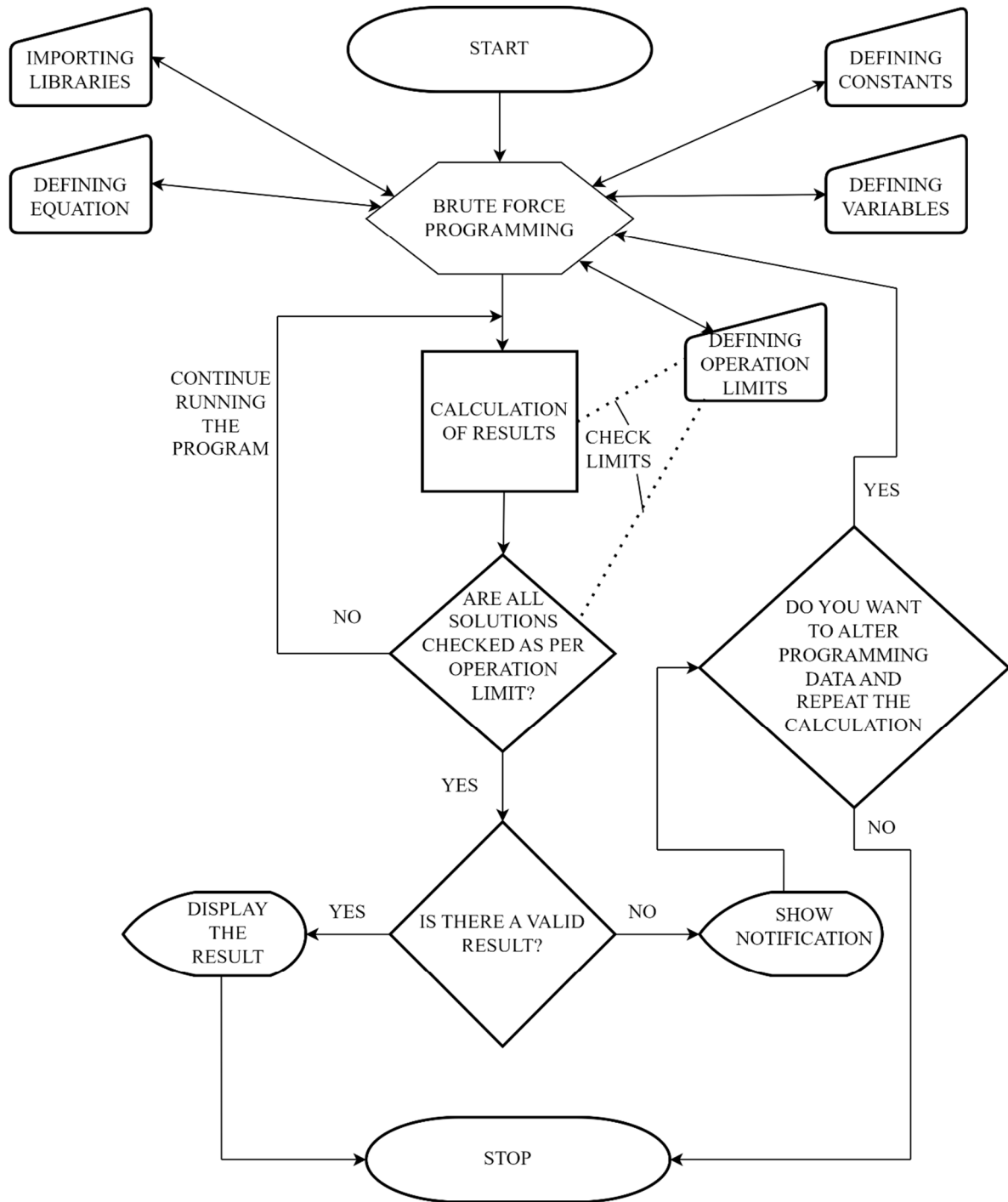

**Figure 29. Brute force flow diagram**

The method uses a direct approach to exhaust all possible outcomes, re-examine and find all possible solutions to a problem, and finally select the optimal solution at the end of the process (if any), as shown in Figure 29.

Although the BFM is easy to implement, it has one major disadvantage: it requires considerable computing power, and the time required to solve it is proportional to the range the method searches and the number of variables. The larger the range and the number of variables,

the longer it takes to apply the method, as shown by the example of Andrade-Cabrera et al. [187], where the BFM required a computation time of 47.56 minutes. Due to this limitation, the method is mainly used when the range of the search is limited and the number of variables is small. Despite this drawback, the method is becoming increasingly popular and is frequently used [36, 37, 38, 188].

As the further development of computers constantly increases computing power and speed [189], it is expected that the use of the BFM will spread over time [174].

The hexagon at the top of Figure 29. shows that the BFM is programmed in the computer at this point. The programming language chosen for this task is Python.

Python is a general-purpose programming language that can be used for a wide variety of applications and is very popular in the programming community. There are several reasons for choosing Python programming language for this task, the main ones being:

- It is freely usable and distributable, even for commercial use [39].
- It is easy to learn [127].
- Its code is well suited for introducing computing and problem solving to beginners [127].
- It is one of the fastest growing languages [128].
- There is a large selection of freely available code (SciPy) [190] that makes creating and modifying code extremely easy [174].

The last point proved to be the most important. The wide range of available programs facilitated the verification of the results obtained, which are presented in Section 6.1.

In this chapter, the methods used in this thesis are presented with the aim of improving the MA-CAD method (a method for modelling LCC created intentionally for shipping industry) and creating a simpler and easier model to solve the cost optimization Equation 75 with variables  $N$  and  $T$ . A potential problem in improving the MA-CAD method is whether the replacement method (PLP) is applicable to this data and whether the method is compatible with the MA-CAD method. Therefore, it is necessary to test the applicability of the PLP method as a replacement for Weibull and whether the PLP method, applied to known data, provides credible results. This test is presented in the next section.

## **4. TEST OF THE PROPOSED CHANGES**

The introduction states that MA-CAD is a scientific method for modelling the maintenance of ship mechanical systems, taking into account LCC. The scientific method can be defined as a “*principle and procedure for the systematic pursuit of knowledge involving the recognition and formulation of a problem, the collection of data through observation and experiment, and the formulation and testing of hypotheses*” [186].

The idea of simplifying the MA-CAD method (which is the focus of this thesis) should also go through all the steps listed in the description of the method. One of these steps is experimenting and testing the applicability of the proposed changes described in this Chapter. Testing the applicability of the proposed changes starts with analysing MA-CAD failure data [8] for three main engine systems using PLP, and then comparing his results (which he obtained using Weibull) with results of PLP analysis to obtain test result. Next, MA-CAD failure data [8] for three main engine systems is checked by applying the model selection criterion [40, 41] to compare Weibull and PLP. The data of this model is then checked by applying the model selection criterion (Akaike) to determine which model is more appropriate for this data set.

### **4.1. TESTING WITH VERIFIED DATA**

To test whether replacing the Weibull method with the PLP method provides credible (good) results, a comparison of the results obtained with the two methods is carried out. To ensure that the test results are as reliable as possible and that the calculation is unbiased, the already published Weibull data with a known list of failures is used. This data comes from the well-known source of the MA-CAD method [8]. In the aforementioned work, the failure data was analysed using the Weibull method, therefore the failure data only needs to be analysed using the PLP method and the results compared. In [8], several examples of engine operating data are analysed, three of these examples are analysed here using the PLP method, the results are compared and a judgement is made.

#### **4.1.1. Exhaust valves**

The first example is exhaust valves from [8] from Table 6.5. on pages 106 and 107, where all maintenance data are listed. The failure data from [8] are shown in Table 3. and the Weibull data used in [8] are shown in Table 4.

**Table 3. Exhaust valves failure data [8]**

Failure number	Time of occurrence ( $t_i$ ) [h]	Cylinder	Time between failures ( $x_i$ ) [h]
1	74714	5	723
2	33575	3	762
3	73393	2	775
4	67714	3	787
5	88589	6	934
6	87655	6	1006
7	75442	7	1137
8	73991	4	1255
9	73991	5	1271
10	89501	7	1342
11	84054	2	1407
12	80025	3	1612
13	72736	4	1778
14	82647	2	1849
15	65958	4	1939
16	64018	4	1963
17	75442	2	2049
18	72075	7	2139
19	84120	4	2188
20	74305	7	2226
21	54480	1	2232
22	84120	5	2318
23	82370	3	2345
24	77077	5	2363
25	66927	3	2398
26	35689	6	2409
27	80798	2	2446
28	62037	6	2496
29	75229	3	2515
30	88156	1	2618
31	69838	5	2650
32	72720	5	2882
33	78352	2	2910
34	81932	4	2941
35	85469	3	3099
36	86944	2	3118
37	78413	3	3184
38	88159	7	3226
39	54541	6	3852
40	86649	6	3894
41	62056	4	4243
42	82755	6	4342
43	64529	3	4389
44	79933	7	4491
45	62405	2	4507
46	67188	5	4582
47	81802	5	4725
48	52898	2	5098
49	72618	2	5213
50	79979	1	5219
51	74760	1	5280
52	85541	1	5562
53	88183	4	6251
54	78413	6	6376
55	55140	3	6575

Table 3. shows failures in the exhaust valve system, the first column is the number of the failure, the second column is the time of the failure, the third column is the number of the cylinder in which the failure occurred, and the fourth column is the interval between the failures. The table is sorted by the fourth column, ascending from smallest to largest. Table 4. lists the data taken from [8].

**Table 4. Exhaust valves Weibull parameters [8]**

$\hat{\beta}_w$	$\hat{\eta}$ [h]	MTBF [h]	Average running hours annually [h]	Spare parts for corrective maintenance = int (4700/2943)	Safety minimum spare parts (as per class. requirements)	Overhaul time [h]
2	3333	2943	4700	2 units	2 units	3400

\*MTBF (Mean Time Between Failures)

The PLP parameters of the data presented in Table 3. are estimated using Equations 27 and 28 for failure truncated data, without additional information on data collection, this method remained only proper choice for estimation. Due to identified discrepancies (missing data), the time of the third failure is considered as time 0 in the estimation. The estimated parameters are shown in Table 5. The number of spare parts  $N_{CM}$  required for corrective maintenance in the analysed period is estimated according to Equation 37 from section 3.2.

$$H^{PLP}(t) = 1.8765$$

The quantity of spare parts required for corrective maintenance is estimated according to Equation 41 from section 3.2. and amounts to:

$$\text{int}(1.8765) > H^{PLP}(t) = 2 \text{ units.}$$

The confidence interval is obtained using the confidence estimators  $II_1$  and  $II_2$  according to Equation 40 from section 3.2. to:

$$CI = [1.1900, 2.7562]$$

The influence of the confidence interval is visible in this example, if the number of spare parts is calculated according to the upper confidence limit, then the following result is obtained:

$$\text{int}(2.7562) > H_U^{PLP}(t) = 3 \text{ units}$$

The recommended maintenance interval is calculated according to Equation 45 at  $T = 3558$  hours with 95% reliability. This value increases to 5552 hours if the reliability is reduced to 90%. All results displayed as PLP calculated data apply to a reliability of 95% reliability and a normal confidence value.

Table 5. shows the cumulative calculation results.

**Table 5. Exhaust valves PLP parameters**

$\hat{\beta}_w$	$\hat{\theta}$ [h]	Spare parts for corr. maintenance = int (1.8765)	Safety minimum spare parts (as per class. requirements)	Calculated overhaul time [h]
1.6184	22299.845	2 units	2 units	3500

#### 4.1.1. Fuel injectors

The second example is fuel injectors. The data in Tables 6. and 7. are taken from [8], Table 6.5, page 111, 112 and page 114. Table 6. lists the data taken from [8] without any changes.

**Table 6. Fuel injectors Weibull parameters [8]**

$\hat{\beta}_w$	$\hat{\eta}$ [h]	MTBF [h]	Average running hours annually [h]	Spare parts for corr. maintenance = int (4700/1844)	Safety minimum spare parts (as per class. requirements)	Overhaul time [h]
1.8	2026	1844	4700	3 units	1 unit	2000

PLP parameters of the data for fuel injectors presented in Table 7. are estimated using Equations 27 and 28. The estimation is performed using equations for failure truncated data. Due to identified inconsistencies (missing data), the time of the first failure is considered as time 0 in the calculation. The calculated parameters are listed in Table 9.

**Table 7. Fuel injectors failure data [8]**

Failure number	Time of occurrence ( $t_i$ ) [h]	Cylinder	Time between failures ( $x_i$ ) [h]
1	47216	1	13
2	47248	1	32
3	66927	3	116
4	82861	3	147
5	82539	3	169
6	67714	5	503
7	82382	3	698
8	61403	5	710
9	33575	3	742
10	68536	5	822
11	66811	3	1116
12	64019	4	1121
13	54541	6	1160
14	82714	3	1175
15	58695	5	1183
16	78930	4	1194
17	47203	1	1232
18	70770	6	1233
19	82128	2	1330
20	81672	3	1443
21	89501	7	1459
22	86125	2	1497
23	55140	3	1565
24	72722	5	1686
25	52512	1	1699
26	78930	5	1716
27	72736	4	1778
28	80798	2	1790
29	50064	4	1829
30	80798	4	1868
31	65958	4	1939
32	54480	1	1968
33	74714	5	1992
34	84120	5	1992
35	60695	5	2000
36	35667	3	2092
37	80845	6	2432
38	62037	6	2496
39	43381	6	2601
40	65218	7	2611
41	78413	6	2643
42	75442	7	2724
43	88669	6	2824
44	52607	7	2912
45	82128	5	3198
46	42697	1	2300
47	35667	1	2496
48	59573	1	2593
49	64019	5	2616
50	43235	4	2640
51	52898	4	2834
52	88022	1	2888
53	60695	3	3055
54	70134	1	3061
55	67211	5	3192
56	50813	1	3265
57	45971	1	3280
58	75229	3	3302

The number of spare parts  $N_{CM}$  required for corrective maintenance in the analysed period is calculated according to Equation 37.

$$H^{PLP}(t) = 1.6923$$

The quantity of spare parts required for corrective maintenance is calculated according to Equation 41. and amounts to:

$$\text{int}(1.6923) > H^{PLP}(t) = 2 \text{ units}$$

The recommended maintenance schedule is calculated according to Equation 45 to  $T = 2806$  hours of operation with the reliability of 95%.

The calculation summary using PLP method are shown in Table 8.

**Table 8. Fuel injectors PLP parameters**

$\hat{\beta}_{PLP}$	$\hat{\theta}$ [h]	Spare parts for corr. maintenance = int (1.6923)	Safety minimum spare parts (as per class. requirements)	Calculated overhaul time [h]
1.4202	22715.4689	2 units	1 unit	2800

#### 4.1.2. Fuel pumps

The third control example are fuel pumps, data shown in Tables 9. and 10. are taken from [8] from Table 6.8, and from pages 115, 116, and from page 114.

**Table 9. Fuel pumps Weibull parameters [8]**

$\hat{\beta}_w$	$\hat{\eta}$ [h]	MTBF [h]	Average running hours annually [h]	Spare parts for corr. maintenance = int (4 700/7945)	Safety minimum spare parts (as per class. requirements)	Calculated overhaul time [h]
1.82	8978	7945	4700	1 unit	1 unit	9000

PLP parameters of the data for fuel injectors presented in Table 7. are estimated using Equations 27 and 28. The estimation is performed using equations for failure truncated data.



**Table 10. Fuel pumps failure data [8]**

Failure number	Time of occurrence ( $t_i$ ) [h]	Cylinder	Time between failures ( $x_i$ ) [h]
1	88712	3	2063
2	86648	3	4722
3	81932	5	4895
4	66927	3	5402
5	79979	1	9845
6	61525	3	13391
7	48134	3	15301

Due to identified inconsistencies (missing data), the time of the first failure is considered as time 0 in the calculation. Calculated quantity of spare parts for corrective maintenance:

$$H^{PLP}(t) = 0.0600$$

$$\text{int}(0.06) > H^{PLP}(t) = 1 \text{ unit}$$

Recommended maintenance interval is calculated to  $T = 30898$  hours of operation with the reliability of 95%. The calculation summary using PLP method are shown in Table 11.

**Table 11. Fuel pumps PLP parameters**

$\hat{\beta}_w$	$\hat{\theta}$ [h]	Spare parts for corr. maintenance = int(0.06)	Safety minimum spare parts (as per class. requirements)	Calculated overhaul time [h]
1.4202	22715.4689	1 unit	1 unit	30000

#### 4.1.3. Comparison of parameters

Table 12. contains a compilation of data from calculated by [9] which were presented in Tables 4., 6, and 9., and is used to compare that data with data calculated using PLP method which was presented in Tables 5., 8. and 11.

**Table 12. Comparison of parameters**

	Weibull		PLP	
	Spares for corr. maintenance	Calculated overhaul time [h]	Spares for corr. maintenance	Calculated overhaul time [h]
Exhaust valves	2	3400	2	3500
Fuel injectors	3	2000	2	2800
Fuel pumps	1	9000	1	30000

The result of the first example agrees completely, there is only a slight difference in the calculation of the overhaul time, which is less than 3%. In the second example, there is a difference in the quantity of spare parts for corrective maintenance (one set more in the PLP calculation) and a difference of 40% in the calculated overhaul time. If no inconsistencies are removed from this calculation, the results look slightly different: There is still a difference in the spare parts quantity, but the difference in the calculated overhaul time is reduced to less than 30%.

The results of the PLP analysis of the third example do not match the Weibull analysis, the results are different. Due to the small sample, the calculated results are questionable, which can (should) be attributed to the confidence limits (very wide for a small sample).

If the third sample is excluded, the results obtained are close enough to the expectations based on the results of other studies [142, 157].

## **4.2. SHIPS FAILURE DATA ANALYSIS**

The injection system analysed is a complex system consisting of a large number of parts, each of which can have its own failure mode. From the records in the CMMS, it was not possible to reliably read the exact failure modes at each point in time and thus calculate the failure rate function for each individual component. For this reason, it is assumed in this thesis that all individual components are subject to wear and the failure rate function shown consists of the sum of the failure rates of all individual components. The resulting failure rate without maintenance tends to increase over time.

### **4.2.1. Ship 1 data**

At the time of data collection, the ship under investigation had been in operation for more than seven years, and during this time the main engine had been in operation for 44371 hours, which corresponds to an average of 6193 hours per year. As data collection ends at this point, this example is considered to be time truncated [24, 122, 154, 191].

Table 13. shows the failure data for ship 1. The first column shows the number of the failure  $i_l$ , the second column the time of occurrence  $t_{i_l}$  and the third column the time between the individual failures  $x_{i_l}$ .

**Table 13. Failure data, ship 1**

$i_1$	$t_{i1}$	$x_{i1}$
1	4121	4121
2	5306	1185
3	13012	7706
4	17420	4408
5	21877	4457
6	26980	5103
7	27380	400
8	33161	5781
9	37553	4392
10	40089	2536
11	41699	1610

Figure 30. shows the failure data for ship 1. Monitoring starts at time 0, each failure time is indicated next to the failure. The time of truncation is indicated in the figure with a red number and a red line.

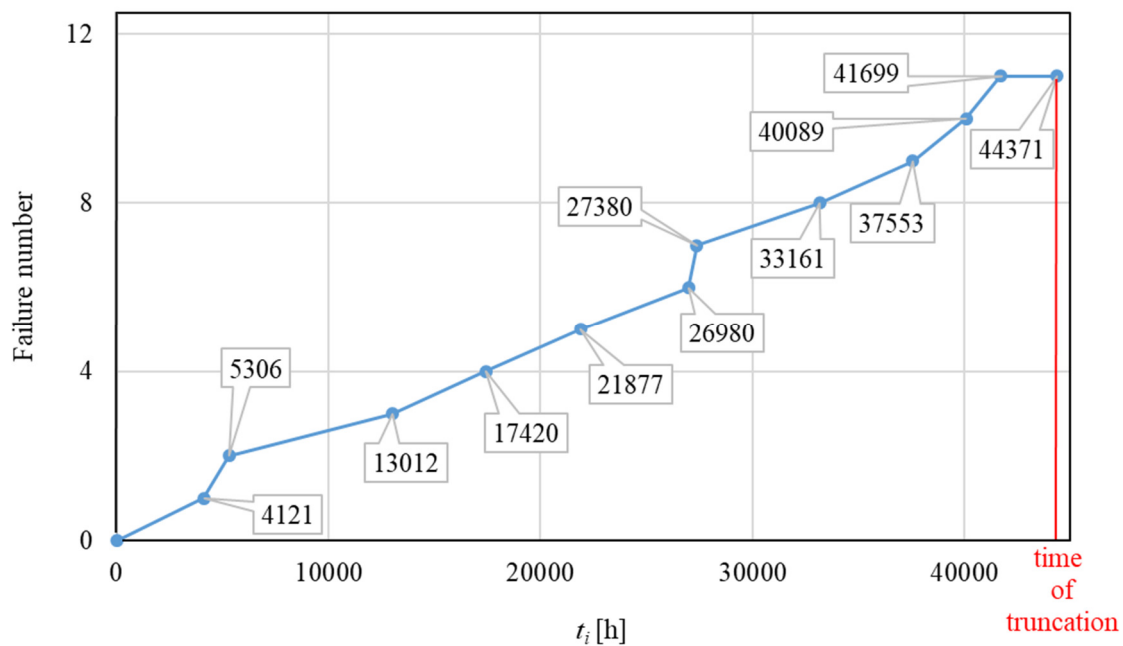

**Figure 30. Failure data for ship 1**

#### 4.2.2. Ship 2 data

Ship 2 was in operation for a slightly longer period of time than ship 1. During this time, the main engine ran for 47660 hours, which corresponds to an average of 6484 running ours per year. As the data collection ends at this point, this example is also considered to be time truncated [24, 122, 154, 191].

Table 14. shows the failure data for ship 2. The first column shows the number of the failure  $i_{II}$ , the second column the time of occurrence  $t_{iII}$  and the third column the time between the individual failures  $x_{iII}$ .

**Table 14. Failure data, ship 2**

$i_{II}$	$t_{iII}$	$x_{iII}$
1	7263	7263
2	13614	6351
3	15091	1477
4	17636	2545
5	19266	1630
6	27417	8151
7	32410	4993
8	45601	13191

Figure 31. shows the failure data for ship 2. The failure times are indicated for each failure. The truncation time is indicated in red.

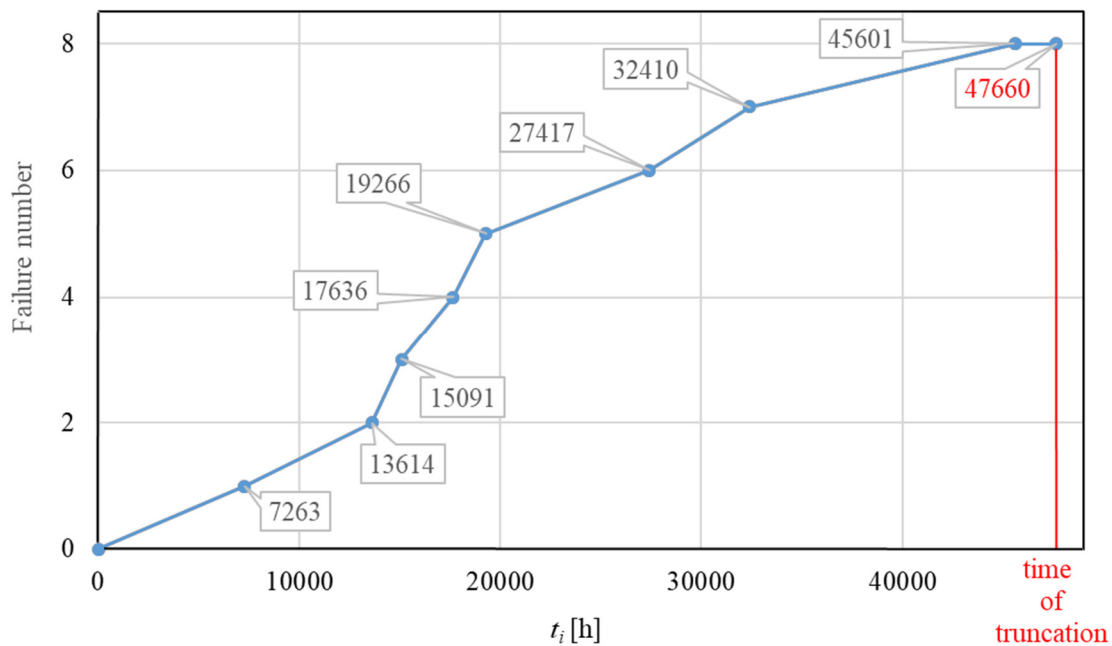

**Figure 31. Failure data for ship 2**

#### 4.2.3. PLP parameter estimation for ship 1

For all further calculations it is necessary to estimate the parameters for both ships. To estimate the PLP parameters, MLE estimation is used using the data presented in Section 4.2.1. and Equations 29. and 30 [24], since the failure data are time truncated in time truncated. The

estimation is shown below, noting that the postscript “I” has been added to differentiate the parameters for ship 1:

$$\widehat{\beta}_1^{PLP} = \frac{11}{8.9563} = 1.2282$$

$$\widehat{\theta}_1^{PLP} = \frac{44371.6}{11^{\frac{1}{1.2282}}} = 37787.0917 \text{ [h]}$$

The estimated results are  $\widehat{\beta}_1^{PLP} > 1$ , showing that this is deteriorating. The confidence interval in the case of time-truncated data for  $\widehat{\beta}_1^{PLP}$  is based on the result that  $2n\beta/\widehat{\beta}$  has a  $\chi^2$  (chi-square) distribution with  $2n$  degrees of freedom, therefore a  $100(1 - \alpha)\%$  confidence interval for  $\widehat{\beta}_1^{PLP}$  can be expressed [120]:

$$\left( \frac{\widehat{\beta}_1^{PLP} \chi_{2n, 1-\alpha/2}^2}{2n}, \frac{\widehat{\beta}_1^{PLP} \chi_{2n, \alpha/2}^2}{2n} \right) \quad (76)$$

In this case, there are 11 failures, so the  $\chi^2$  distribution with 22 degrees should be adopted for 2.5 and 97.5 probabilities:

$$(\chi_{22, 1-\alpha/2}^2, \chi_{22, \alpha/2}^2) = (10.982, 36.781)$$

The above values are inserted into Equation 75, the 95% confidence interval for  $\widehat{\beta}_1^{PLP}$  :

$$CI_1^{\beta_1^{PLP}} = (0.6131, 2.0534)$$

The confidence interval for  $\widehat{\theta}_1$  cannot be accurately determined, according to researchers in the field [24, 120]. Therefore, a method recommended by Bain and Engelhardt [144] and Rigdon and Basu [24] is used to estimate the confidence interval for  $\widehat{\theta}$  :

$$\widehat{\theta}_L = \widehat{\theta} \left\{ n \left[ (n+1) \omega_{n+1, 1-\alpha/2} \right]^{\frac{-n}{n+1}} \right\}^{\frac{1}{\widehat{\beta}_1^{PLP}}} \quad (77)$$

$$\hat{\theta}_U = \hat{\theta} \left\{ n \left[ (n+1) \omega_{n+1, \alpha/2} \right]^{\frac{-n}{n+1}} \right\}^{\frac{1}{\hat{\beta}_{PLP}}} \quad (78)$$

where:

$\omega$  – approximation factor

In this case, following [157], values for  $\alpha/2$  are approximated for 95% confidence interval:

$$\omega_{n+1, 1-\alpha/2} = 0.3633$$

$$\omega_{n+1, \alpha/2} = 24.333$$

Values for 95% confidence interval for  $\hat{\theta}_I$  are estimated to:

$$CI_I^{\hat{\theta}} = (88714.91, 3847.7371)$$

The reliability of MLE estimate  $R_I(t | \hat{\beta}_{PLP}, \hat{\theta})$ , lower  $R_{I-L}(t | \hat{\beta}_{PLP}, \hat{\theta})$ , and upper confidence interval limits  $R_{I-U}(t | \hat{\beta}_{PLP}, \hat{\theta})$  are shown in Figure 32. The hours of the system are set to 48000, and further analysis is stopped due to the very low results.

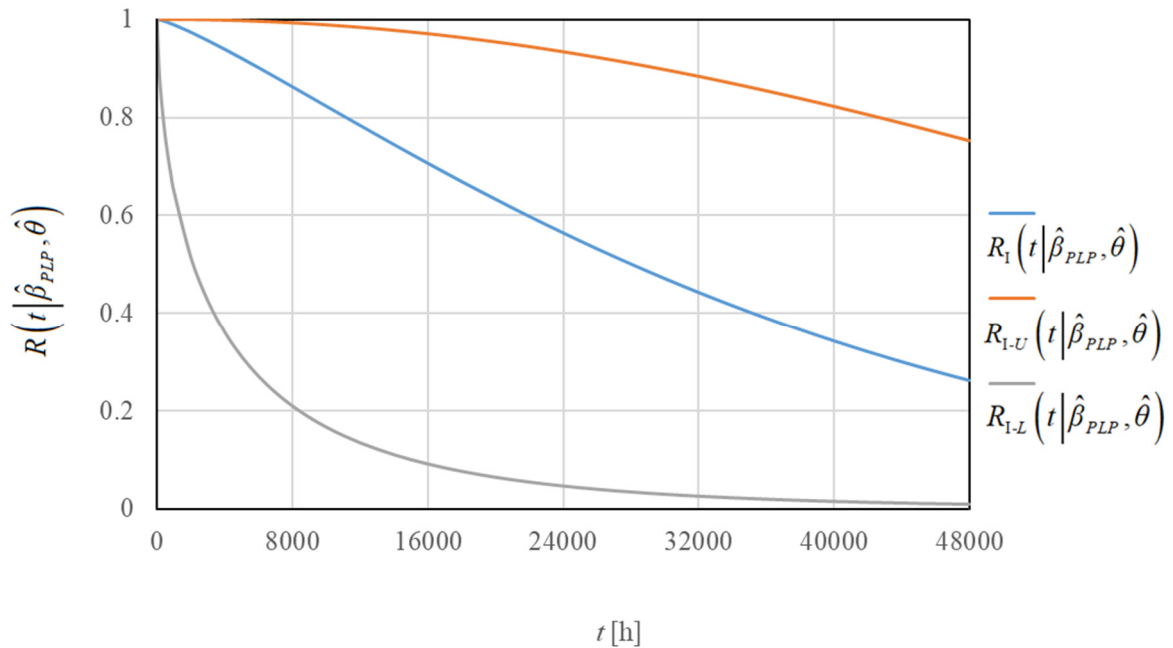

**Figure 32. Reliability comparison of ship 1**

#### 4.2.4. PLP parameter estimation for ship 2

The data presented in section 4.2.2. are used to estimate the PLP parameters of ship 2. Equations 29. and 30 [24] are applied as the failure data are time truncated. The whole process is shown below, noting that the subscript “II” was added to differentiate the parameters for ship 1. The MLEs for  $\beta_{PLP}$  and  $\theta$  are estimated as in the previous example [24]:

$$\hat{\beta}_{II}^{PLP} = \frac{8}{7.1669} = 1.1162$$

$$\hat{\theta}_{II} = \frac{47660 \cdot 6}{\frac{1}{8^{1.1162}}} = 44387.452 \text{ [h]}$$

The estimated results are  $\hat{\beta}_{II}^{PLP} > 1$ , showing that this system also deteriorates. In Equation 75, according to [24] and [157], the 2.5 and 97.5 percentage points of the  $\chi^2$  distribution with 16 degrees of freedom are:

$$(\chi_{16, 2n, 1-\alpha/2}^2, \chi_{16, 2n, \alpha/2}^2) = (28.845, 6.908)$$

The above values are inserted into Equation 75, and obtained results for the 95% confidence interval for  $\hat{\beta}_{II}^{PLP}$  are:

$$CI_{II}^{\beta_{II}^{PLP}} = (0.4819, 2.0124)$$

The confidence limits for  $\hat{\theta}_{II}$  are approximated for 95% confidence interval:

$$\omega_{n+1, 1-\alpha/2} = 0.408$$

$$\omega_{n+1, \alpha/2} = 43.667$$

Values for 95% confidence interval for  $\hat{\theta}_{II}$  are calculated to:

$$CI_{II}^{\theta_{II}} = (16916.4, 409.43)$$

The reliability of MLE estimate  $R_{II}(t|\hat{\beta}_{PLP}, \hat{\theta})$ , lower  $R_{II-L}(t|\hat{\beta}_{PLP}, \hat{\theta})$ , and upper confidence interval  $R_{II-U}(t|\hat{\beta}_{PLP}, \hat{\theta})$  are shown in Figure 33. The hours of the system are set to 48000, and further analysis is stopped due to the very low results.

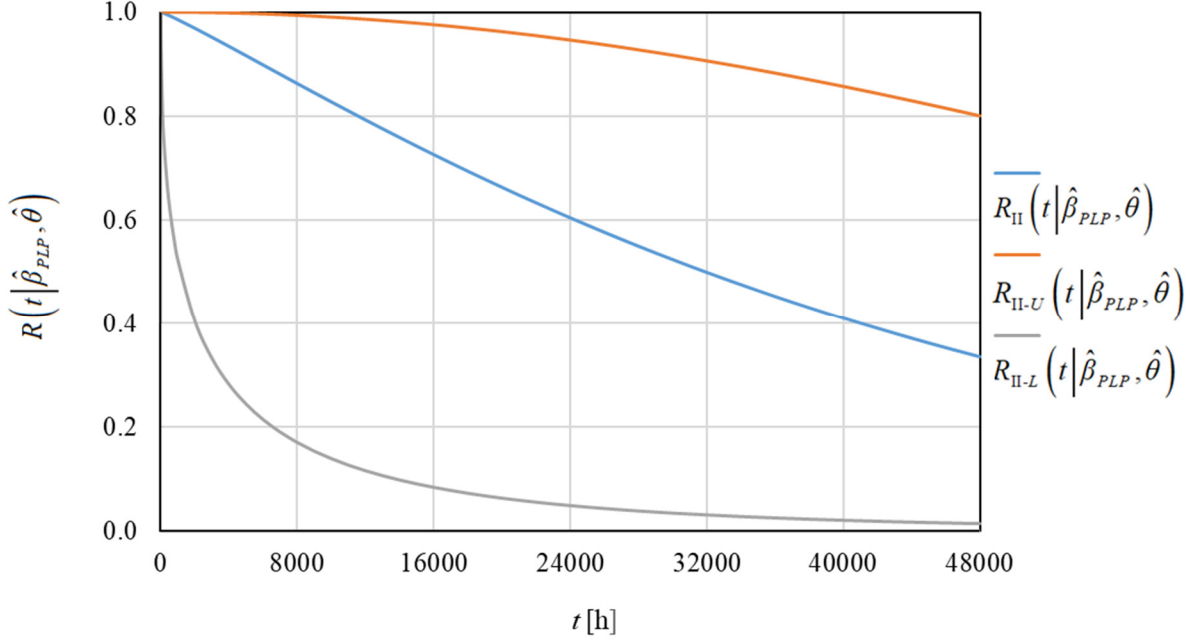

Figure 33. Reliability comparison of ship 2

#### 4.2.5. PLP parameters estimation for system of two ships

In the two reliability estimations above, it was assumed that each ship is a separate, independent unit. Since they are sister ships with the same types, the entire analysis can be performed by considering them as identical parts of a system [24, 119, 121 – 123, 143, 192], and estimating the parameters for both together.

This estimation also starts with the data from Tables 13. and 14. The first step in estimating the system data is to calculate the number of failures in the system, which is equal to the sum of all failures of all systems, as shown in Equation 79:

$$N = n_1 + n_2 + \dots + n_q = \sum_{q=1}^k n_q \quad (79)$$

where:

$k$  – number of systems,

$n_q$  – number of failures per ship.



The parameters for the system are estimated according to Equations 80 and 81 [120, 122], where Equation 80 is nonlinear:

$$\widehat{\beta}_s^{PLP} = \frac{n_q}{\sum_{q=1}^k \left( \frac{T_q}{\theta_s} \right)^{\widehat{\beta}_s^{PLP}} \cdot \ln(T_q) - \sum_{q=1}^k \sum_{i=1}^{m_q} \ln(t_{iq})} \quad (80)$$

$$\widehat{\theta}_s = \left( \frac{\sum_{q=1}^k (T_q)^{\widehat{\beta}_s^{PLP}}}{n_q} \right)^{\frac{1}{\widehat{\beta}_s^{PLP}}} \quad (81)$$

Here too, as with the evaluation of the parameters for a ship, there are two different possibilities for evaluation. The difference lies in the values of  $T_q$  and  $m_q$ . If the data are failure truncated, the value  $T_q = t_n$  (time of the last failure), and  $m_q = n_q - 1$ . If the data are time truncated, then  $T_q = t_T$  (time of the end of the data collection, i.e. time of the time truncation) and  $m_q = n_q$ .

The data in Table 15. show the comparison of MLEs for two ships and for the system. Following the general goal of simplicity of the procedures, the iteration is performed using an Excel file. The approximate result for  $\widehat{\beta}_s^{PLP}$  was obtained in the fifth iteration with an accuracy of eight decimal places. To obtain the result for  $\widehat{\theta}_s$  with the same accuracy, seven iterations were required.

**Table 15. PLP parameter estimation results**

Ship 1		Ship 2		System	
$n_{I=}$ 11		$n_{II=}$ 8		$n_S=$ 19	
$\widehat{\beta}_I^{PLP}$	1.2282	$\widehat{\beta}_{II}^{PLP}$	1.1162	$\widehat{\beta}_S^{PLP}$	1.1686
$\widehat{\theta}_I$	37787.0913	$\widehat{\theta}_{II}$	44387.4516	$\widehat{\theta}_S$	40219.7284

The data for the system of two ships show that the values for both parameters are in the range between the same parameters of these two ships. It is therefore to be expected that the reliability diagram for the system shows a similar behaviour as for each individual ship.

Figure 34. (excerpt from the overall picture, up to 7000 hours), confirms that all three curves show a similar behaviour with slight changes in the values.

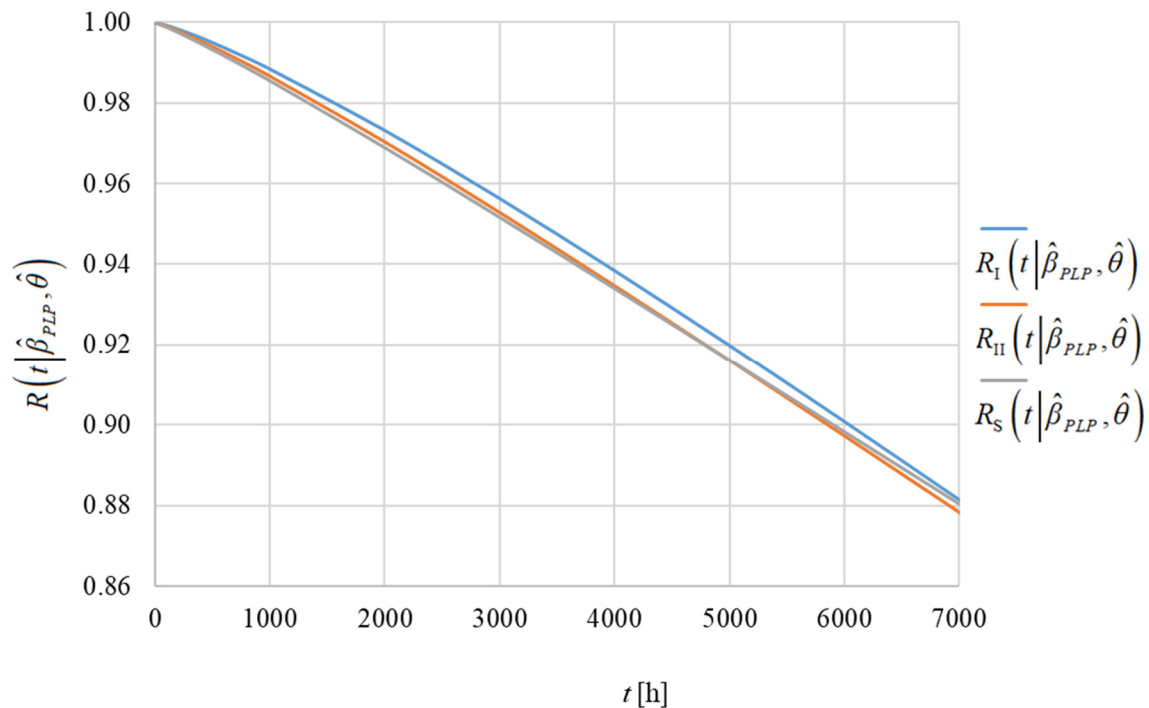

**Figure 34. Reliability comparison**

Chapter 5 will show how the values obtained from the above calculation can be used as a source for a proactive approach to maintenance and spare parts planning.

### 4.3. AKAIKE INFORMATION CRITERION

Statistical modelling is an important tool in science. Statistical models are used to test system structures and predict behaviours by introducing certain reliability coefficients. Statistical analysis aims to analyse and represent information from data, i.e. from the systems themselves. Statistical models are used for simpler analyses that allow conclusions to be drawn about a range of information and systems. The selection and evaluation of a statistical model is a very important issue, and a good analysis allows the selection of the most appropriate model [193]. An information criterion checks the following properties:

- the compatibility of the model and the data,
- the complexity of the model.

The most commonly used model selection criteria are the Bayesian Information Criterion (BIC) [40, 41, 115, 193 – 195], the Akaike Information Criterion (AIC) [40, 115, 193 – 195] and the Generalised Information Criterion (GIC) [40].

The Akaike Information Criterion (AIC) [40, 115, 193 - 195] is used in statistics to compare different possible models and determine which one is the best fit to the data. This criterion is used in this thesis to compare Weibull and PLP.

AIC is calculated using the number of independent variables that make up the model and it estimates how well the model fits the data. AIC [40, 115, 193 - 195], calculates the results based on Equation 82:

$$AIC = -2 \log L(\hat{\varphi}) + 2p \quad (82)$$

where:

$L(\hat{\varphi})$  – the likelihood function of MLE of  $\varphi$ , where  $\varphi$  is unknown parameter,

$p$  - the number of estimated parameters.

In the case of small sample sizes, a second order AIC ( $AIC_c$ ) [115] should be used instead:

$$AIC_c = -2 \log L(\hat{\varphi}) + 2p + \frac{2p+1}{(n-p-1)} \quad (83)$$

where:

$n$  – number of failures.

According to [115], the sample can be considered small if  $n/p$  is smaller than 40. Since both samples studied in this thesis fall into this category, a second-order AIC ( $AIC_c$ ) is used for the analysis. After the calculation, the estimates with smaller values of AIC considered better suited to the set of data.

#### 4.3.1. Ships failure data $AIC_c$ test

The first step is to calculate the likelihood of the Weibull distribution for failure data using Equation 9., to obtain Likelihood (L) of the function, and then Log Likelihood (LL).

Calculation of likelihood of the PLP distribution for specific data is performed using Equation 24, and then obtain LL.

The calculation of  $AIC_c$  is done step by step (using MLE at the time of failure) for each failure. Tables 16., 17., 18., and 19. show the results of the calculations performed by using the MLE for each failure. Tables 16. and 17. show the results for ship 1, and Tables 18. and 19. are showing data for ship 2.

**Table 16.  $AIC_c$  of Weibull method for ship 1**

Failure number	MLE of $\beta_w$	MLE of $\eta$	$AIC_c$
1	52.1094	33763.8	46.2922
2	2.1409	24349.6563	65.4226
3	1.8208	39261.6495	n/a*
4	2.1766	39737.5671	119.2124
5	2.4863	39920.6427	138.0096
6	2.8099	40878.9454	158.2808
7	1.7724	34912.2693	181.794
8	1.9504	37159.2898	203.1334
9	2.129	37511.8999	224.2606
10	2.134	36162.5455	245.8958
11	2.0129	34263.9	268.0123

\* $AIC_c$  for in this analysis with 2 parameters cannot be computed for 3 samples (dividing by zero).

**Table 17.  $AIC_c$  of PLP method for ship 1**

Failure number	MLE of $\beta_{PLP}$	MLE of $\theta$	$AIC_c$
1	0.4208	266226	25.6173
2	0.4444	55962.5041	45.9443
3	0.5238	32691.4057	n/a*
4	0.6004	26456.4577	101.8457
5	0.6785	24836.9778	121.5837
6	0.7627	25410.9893	142.7604
7	0.8384	26136.6394	162.6543
8	0.9259	28174.2127	185.0496
9	1.0219	31004.9565	205.2801
10	1.1225	34226.6426	224.8351
11	1.2262	37666.0585	244.2820

\* $AIC_c$  for in this analysis with 2 parameters cannot be computed for 3 samples (dividing by zero).

**Table 18.  $AIC_c$  of Weibull method for ship 2**

Failure number	MLE of $\beta_w$	MLE of $\eta$	$AIC_c$
1	4827.7623	43639.9697	19.6232
2	19.886	56839.6506	48.1435
3	2.2901	45835.0513	n/a*
4	2.107	40368.1396	104.3695
5	1.8403	35141.9227	123.9235
6	1.9042	41631.5136	145.5018
7	2.1120	42355.4379	166.6302
8	1.7661	51604.5385	190.5468

\* $AIC_c$  for in this analysis with 2 parameters cannot be computed for 3 samples (dividing by zero).

**Table 19. AIC<sub>c</sub> of PLP method for ship 2**

Failure number	MLE of $\beta_{PLP}$	MLE of $\theta$	AIC <sub>c</sub>
1	0.5316	285960	26.3241
2	0.6381	96504.4053	47.7996
3	0.7002	59556.6766	n/a*
4	0.7578	45900.9093	103.1063
5	0.8085	39065.4564	122.5249
6	0.8906	38243.3494	144.8429
7	0.9828	39481.0535	165.2101
8	1.1162	44387.4516	188.7742

\*AIC<sub>c</sub> for in this analysis with 2 parameters cannot be computed for 3 samples (dividing by zero).

Tables 16. – 19. show a strong oscillation of the two parameters defining the applied models, which decreases with increasing number of failures (samples). The differences between the calculated values are very large, differences are decreasing as the sample size increases, showing again the problem of the small sample.

The cumulative results of the calculation of the AIC<sub>c</sub> are shown in Table 20. The first column for each ship shows the Weibull method, while the second column shows the PLP method.

**Table 20. AIC<sub>c</sub> final results**

Ship 1		Ship 2	
Weibull	PLP	Weibull	PLP
268.0123	244.2820	190.5468	188.7742

As can be seen from Table 20., the AIC<sub>c</sub> results show lower values for the PLP distribution. This can be interpreted to mean that the PLP distribution is a better fitting model than the Weibull distribution for both data sets. This calculation is an argument in favour of replacing the Weibull distribution with the PLP distribution in the MA-CAD method.

Another important step in determining whether the proposed changes are applicable is performed by testing the proposed changes on verified data, which is shown in the next section.

#### 4.3.2. MA-CAD failure data AIC test

The calculation of the Akaike information criterion was also performed for the data listed in Tables 3., 7. and 10. in order to check whether the PLP model fits the data better than the Weibull model in this case. The results of the analysis are shown in Table 21.

**Table 21. AIC and AIC<sub>c</sub> test of MA-CAD failure data**

Exhaust valves AIC		Fuel injectors AIC		Fuel pumps AIC <sub>c</sub>	
Weibull	PLP	Weibull	PLP	Weibull	PLP
309.1650	120.6859	311.2305	149.5830	51.8477	51.4317

From Table 21., it can be concluded that in the case of the MA-CAD failure data, PLP is a better fitting model than the Weibull model for the first two data sets, while in the third case the result is almost the same, slightly in favour of PLP. AIC was used for the first two data sets, while AIC<sub>c</sub> was used for the third data set due to the small sample size, as explained in Section 4.3.

#### 4.4. APPLICABILITY OF THE PROPOSAL

In the previous sections, the applicability of the proposal was tested in two different ways. The first test using AIC<sub>c</sub> has shown that the PLP distribution is a better fitting model than the Weibull distribution for both data sets, and according to this test the PLP distribution should be used in the analysed examples.

The test, comparing the PLP with the Weibull values for known data, was not as conclusive as the first test, as the differences between the calculated values were large in one of the examples analysed (the third example).

Overall, it can be stated that the applicability of the PLP method in the calculation of spare parts and in the determination of the overhaul time is confirmed in this Section. The sensitivity of the PLP method in relation to the sample size is particularly emphasized. For this reason, analyses using the PLP method should take into account confidence intervals that assume a possible error in the calculation.

The differences in the calculation in the first two examples in Section 4.1. disappear when Equations 38, 39 and 40 are applied because then both differences can be attributed to statistical errors (see Table 22.), differences obtained by two calculations easily fit into the given interval.

**Table 22. Confidence interval estimators range**

	$\Pi_1$	$\Pi_2$	No of failures	Interval span
<b>Exhaust valves</b>	0.6808	1.5768	52	0.896
<b>Fuel injectors</b>	0.6928	1.5563	57	0.8635
<b>Fuel pumps</b>	0.331	4.738	7	4.407

In the analysis of Table 22. the results from Table 12. become clear, as does the deviation of the results of the PLP method from Weibull in the third analysed case. The confidence interval in the analysed case is extremely large, so that the results obtained extend into the interval, i.e. into the possible error range. This comparison clearly shows the problem of PLP analysis, which manifests itself when the method is applied to a small number of samples. As mentioned above, to reduce the error, the estimators  $\hat{H}_1$  and  $\hat{H}_2$  are introduced [121], and the confidence intervals are set as shown in Equations 32, 33 and 34 [24]. To increase the sample size, PLP parameters with confidence estimators for both ships are also estimated in this section. This process is used in the next Section as a basis for the calculation of the spare parts quantity, the planned maintenance interval and for the optimization of maintenance and spare parts.

## 5. THE APPLICATION OF THE PLP

Chapter 3.3. shows how the PLP method can be used as an ADI in spare parts inventory planning as a tool for proactive maintenance adjustment and as a basis for creating an optimization model instead of Weibull. In this part, it is elaborated in detail using the example of two sister ships.

A whole subchapter is dedicated to an important side aspect of this work, the safety critical spare parts and their influence on the total price within the optimization model.

### 5.1. SHIPS SPARE PARTS PREDICTION

#### 5.1.1. Spare parts prediction for ship 1

The spare parts prediction for ship 1 starts with the MLE of the Intensity Function estimated to at the end of the observation period:

$$\hat{u}_1 = 5.0747 \cdot 10^{-5}$$

Estimators  $\Pi_1$  and  $\Pi_2$  are taken from Crow [121] for the 95% confidence intervals for  $N = 11$ ; and the estimators correspond to:

$$\Pi_{1-1} = 0.438$$

$$\Pi_{1-2} = 2.852$$

Confidence interval for  $\hat{u}_1(t)$  is obtained using Equations 32, 33, 34 [24, 157]:

$$CI_{1-LL} \leq \hat{u}_1(t) \leq CI_{1-UL}$$

$$1.7793 \cdot 10^{-5} \leq \hat{u}_1(t) \leq 1.1586 \cdot 10^{-4}$$

In discussing the order period, it was pointed out that in the maritime industry it is usually every three or four months. For this example, the four-month period is assumed.



The number of failures in the period under study (four-month ordering period) can be obtained using Equation 40 [157]:

$$CI_I^{H^{PLP}}(t_R | \hat{\beta}_{PLP}, \hat{\theta}_{PLP}) = [H_{VLL}^{PLP}(t_R), H_{VUL}^{PLP}(t_R)] = [0.0916, 0.5969]$$

Required spare part sets for those failures are:

$$N_{C-I} \geq \text{int} [0.0916, 0.5969] = [1, 1]$$

Applying this calculation to the prediction of  $N_c$  (the number of spare parts needed to repair ship 1), it can be seen that in both confidence interval limits (lower and upper) one set of spare parts should be ordered to repair the fuel valves.

### 5.1.2. Spare parts prediction for ship 2

The same procedure is applied to ship 2, with the MLE of the Intensity Function at the end of the observation period:

$$\hat{u}_{II} = 3.1228 \cdot 10^{-5}$$

Estimators  $\Pi_1$  and  $\Pi_2$  are taken from Crow [121] for the 95% confidence intervals for  $N=8$ ; the estimators are:

$$\Pi_{\Pi-1} = 0.382$$

$$\Pi_{\Pi-2} = 3.609$$

Confidence interval for  $\hat{u}_{II}(t)$  is obtained using Equations 32, 33, 34 [24, 157]:

$$CI_{II-LL} \leq \hat{u}_{II}(t) \leq CI_{II-UL}$$

$$8.6528 \cdot 10^{-6} \leq \hat{u}_{II}(t) \leq 8.1749 \cdot 10^{-5}$$

Comparing confidence interval for  $\hat{u}_{II}(t)$  with the one in the example above  $\hat{u}_1(t)$ , it is visible that confidence interval for  $\hat{u}_{II}(t)$  is narrower which can be attributed to a greater number of failures.

Number of failures in analysed period (order period of four months) is calculated using the Equation 40:

$$CI_{II}^{H^{PLP}}(t_R | \hat{\beta}_{PLP}, \hat{\theta}) = [H_{II-LL}^{PLP}(t_R), H_{II-UL}^{PLP}(t_R)] = [0.070, 0.6629]$$

Required spare part sets for those failures are:

$$N_{C-II} \geq \text{int} [0.070, 0.6629] = [1, 1]$$

As in the first case, the results of the analysis show that in the cases of the best and worst confidence limits, one set of spare parts should be ordered for corrective maintenance.

### 5.1.3. Spare parts prediction using two ships parameters

If parameters estimated in 4.2.5. are used for prediction of spare parts needed for corrective maintenance, following results are obtained:

In this case Estimators  $\Pi_1$  and  $\Pi_2$  for the 95% confidence intervals for  $N=19$  are:

$$\Pi_{S-1} = 0.532$$

$$\Pi_{S-2} = 2.123$$

The number of expected failures for ship 1 in the studied period (order period of four months) is calculated to values:

$$N_{C-SI} \geq \text{int} [0.1222, 0.4876] = [1, 1]$$

These results confirm the values calculated in 5.1.1., only this confidence interval is much narrower.

The number of expected failures for ship 2 in the studied period is calculated to values:

$$N_{C-SII} \geq \text{int} [0.1255, 0.5008] = [1, 1]$$

Again, the calculated values confirm the previously calculated values (in 5.1.2.), only this range is much narrower, which shows how the sample size affects the overall results.

## 5.2. PLANNED MAINTENANCE SCHEDULE MODIFICATION

The data presented in chapters 4.2.1., 4.2.2., 4.2.3., 4.2.4. and 4.2.5. can (should) be used to calculate the optimal planned maintenance interval in a proactive approach based on failure analysis. The calculation is performed using Equation 45. and the results for the optimal time of planned maintenance  $T_{op}$  are listed in Table 23. Since a number of different values appear in the analysed literature (some say that reliability is never enough [196]), Table 23. shows some of the values commonly used in the literature.

**Table 23. Optimal PM time for different reliability**

Reliability	Ship 1 $T$ [h]	Ship 2 $T$ [h]	System $T$ [h]
0.70	17626	16323	16646
0.80	11579	11142	11143
0.85	8607	8716	8496
0.90	6048	5912	5863
0.925	4733	4514	4531
0.95	3366	3102	3167
0.975	1894	1648	1731
0.99	893	720	785

The reliability of all three calculations shows similar values, with the system recommendations being slightly higher than the other two.

Table 23. shows that the differences between the three options (calculation with three different sets of parameters) do not change the overall results, with differences of up to 11% in the worst case examined (in the case of 95% reliability).

### 5.3. MAINTENANCE AND SPARE PARTS OPTIMIZATION

Optimization is a mathematical method for finding the optimal solution to a problem. Optimization means finding the minimum or maximum value of a function, i.e. finding the most favourable solution by determining certain parameters that satisfy the given condition. Optimization differs in the number of variable parameters, the more there are, the more complex the optimization. Single-parameter optimization was used in the previous Chapter when calculating the required quantity of spare parts for maintenance in a given period and when calculating the recommended time for planned maintenance. In multi-parameter optimization, there are several variable parameters that are varied to meet a specific condition. An example of multi-parameter optimization (two-parameter optimization) is shown in Section 3.6. in Equation 74., where the order quantity  $N^*$  and the preventive maintenance time  $T^*$  are to be determined so that the total cost of maintenance and spare parts  $C_{Tot}(N^*, T^*)$  is minimized. The solution to the above equation is presented in this Section using the data on the failures of the first ship, then the second ship and finally the calculation for both ships.

The usefulness of any model depends on its accuracy, i.e. the reliability derived from its output data. All models can be characterized as an imperfect representation of real cases [197], which also often analyse incomplete data that is available. Therefore, each model is subject to certain uncertainties that can be reduced or influenced. The first way to influence uncertainties is to conduct additional research and collect more data. Another option is to perform a sensitivity analysis to determine the behaviour of the model's output due to changes in the model's input.

In order to check the behaviour of the model again, a sensitivity analysis is carried out immediately after the optimization of the first ship. The sensitivity analysis was performed by changing the degradation coefficient  $\alpha$  and observing the changes in the model results. In the first experiment, the degradation coefficient was first decreased and then increased and results were observed. In the second part of the sensitivity analysis, the limits of the confidence interval for MLE estimates of  $\beta$  and  $\theta$  were inserted in the model to recheck the model behaviour.

#### 5.3.1. Common values for the optimization

When calculating the optimization solution, certain fixed values (constants) are used that are repeated for all calculations in all optimizations of this thesis. These values (presented in Table 24.) are determined as averages from the data in the CMMS and from the review of

the analysed company Safety Management System (SMS). There are some assumptions for items that are not predictable, such as  $C_{Dam}$  or  $C_{CME}$ .

**Table 24. Values of constants in the optimization**

Label	Value	Unit	Label	Value	Unit	Label	Value	Unit
$N_u$	-	6	$C_{MH}$	-	50 [€]	$W$	-	1
$h_{CM}$	-	4 [h]	$C_{Stp}$	-	800 [€]	$C_{Fai}$	-	1200 [€]
$C_{Dam}$	-	2200 [€]	$C_{CMC}$	-	120 [€]	$C_{CME}$	-	300 [€]
$\alpha$	0.1		$h_{PMi}$	-	1 [h]	$P_{PMi}$	-	0.1
$C_{PMiC}$	-	140 [€]	$h_{PMp}$	-	3 [h]	$P_{PMp}$	-	0.05
$C_{PMpC}$	-	400 [€]	$S_{CS}$	-	2	$p_c$	-	0.25
$C_{Spa}$	-	350 [€]	$C_{Hol}$	-	0.0185 [€/h]	$S_S$	-	3
$C_{Han}$	-	1200 [€]	$C_{Cus}$	-	300 [€]	$C_L$	0	[€]

All values are rounded for ease of calculation. In this case, some assumptions are taken from normal practice and definition of maintenance in the model. For the major overhaul, a set of spare parts is needed for every single fuel valve, value of spare parts needed for major overhaul  $N_{PMp}$  is in this case identical to  $N_u$ . Size of spare parts order which is needed for the minor, imperfect overhaul  $N_{PMi}$  is determined from personal experience in the industry. Based on this, the assumption is that every third fuel valve during minor overhaul will need spare parts, therefore  $N_{PMi}$  is adjusted to 1/3 of  $N_{PMp}$ .

### 5.3.2. Optimization results for ship 1

The results of optimization using the BFM are shown in Figure 35. The determination of the order quantity and preventive maintenance time for ship 1, which minimize the total cost of maintenance and spare parts according to Equation 74, is carried out using the parameters calculated in Section 4.2.3. and the fixed values highlighted in Table 24. The result of the optimization shows that the optimal overhaul time is 18500 hours, which is 2500 hours more than the original maintenance schedule prepared by the equipment manufacturer. Overhauling at this time and ordering 3 sets of spare parts results in a minimum total cost  $C_{Tot}$  of 1.5147 €/h.

Figure 35. shows a scenario in which the degradation coefficient is set to  $\alpha = 0.1$ , i.e. degradation factor is  $e^\alpha = 1.105171$ . This value is used as the main value for the optimization of all ships in this thesis. The value of the coefficient is an assumption based on the rechecked

literature [198] and the fact that the value of the coefficient and chosen model depends on the nature of the obtained data and conditions of the equipment use [198, 199].

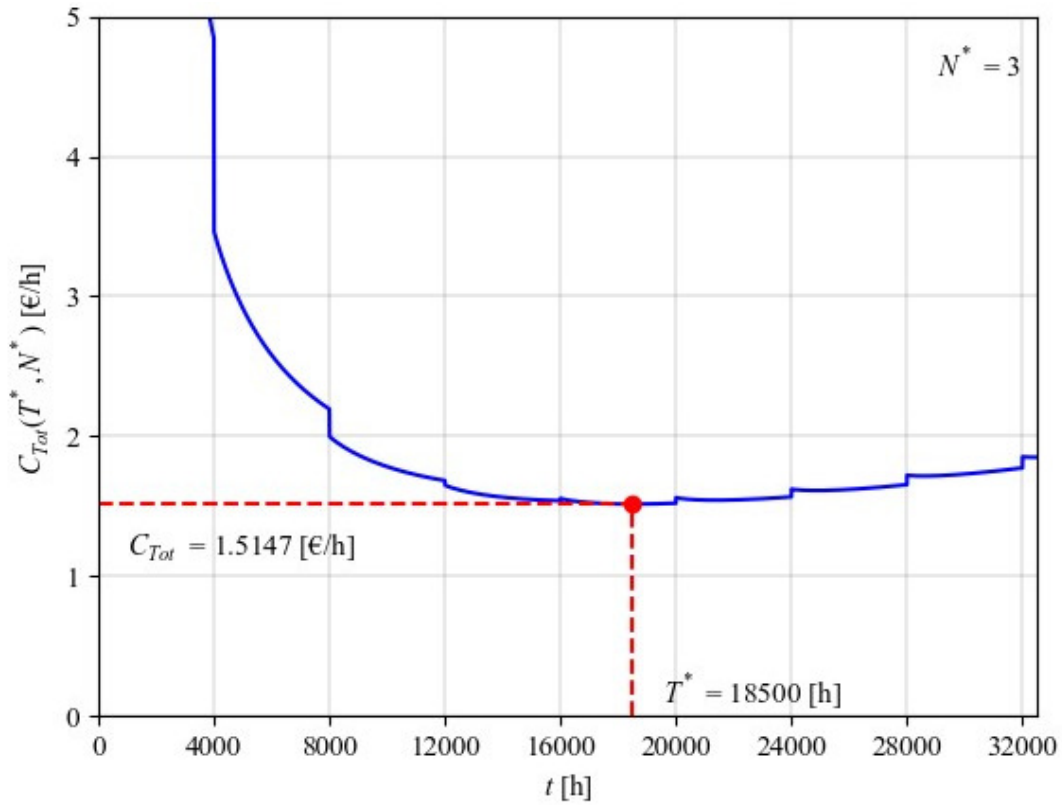

**Figure 35. Cost rate function for ship 1**

Figure 36. shows the relationship between costs and order quantity for ship 1.

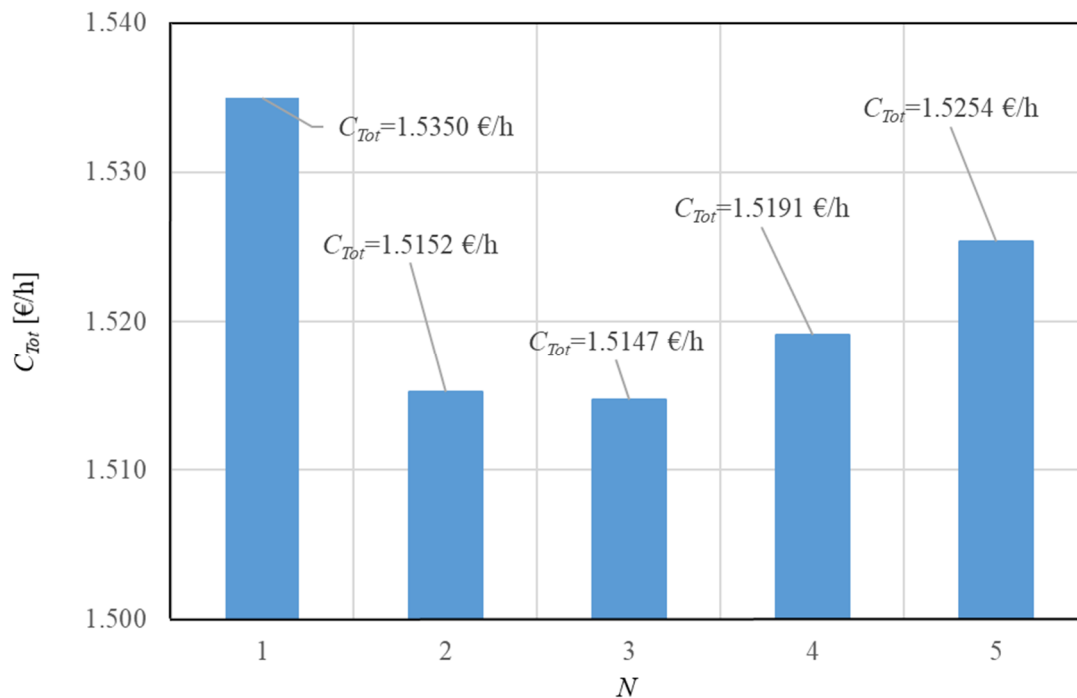

**Figure 36. Costs per unit time for various  $N$  for ship 1**

The results presented in this figure were calculated using an Excel file; the differences between this calculation and the BFM calculation are to the fifth decimal place, which confirms the values determined using the BFM. Figure 36. shows that the costs for  $N = 2$  and  $N = 3$  are almost the same and differ only by a tiny amount of 0.0005 €/h.

It is said that for the optimization in Figure 35, the degradation coefficient is set to  $\alpha = 0.1$ . Realistic scenarios always include a certain degree of degradation, which is intended to simulate reality as far as possible.

### 5.3.3. Sensitivity analysis

In the first part of the sensitivity analysis, the behaviour of the model is analysed when the degradation coefficient  $\alpha$  is below the normal value assumed for the modelling. In a scenario where  $\alpha$  is decreased, the total cost over time  $C_{Tot}(N^*, T^*)$  should decrease and the expected major overhaul time  $T^*$  should increase.

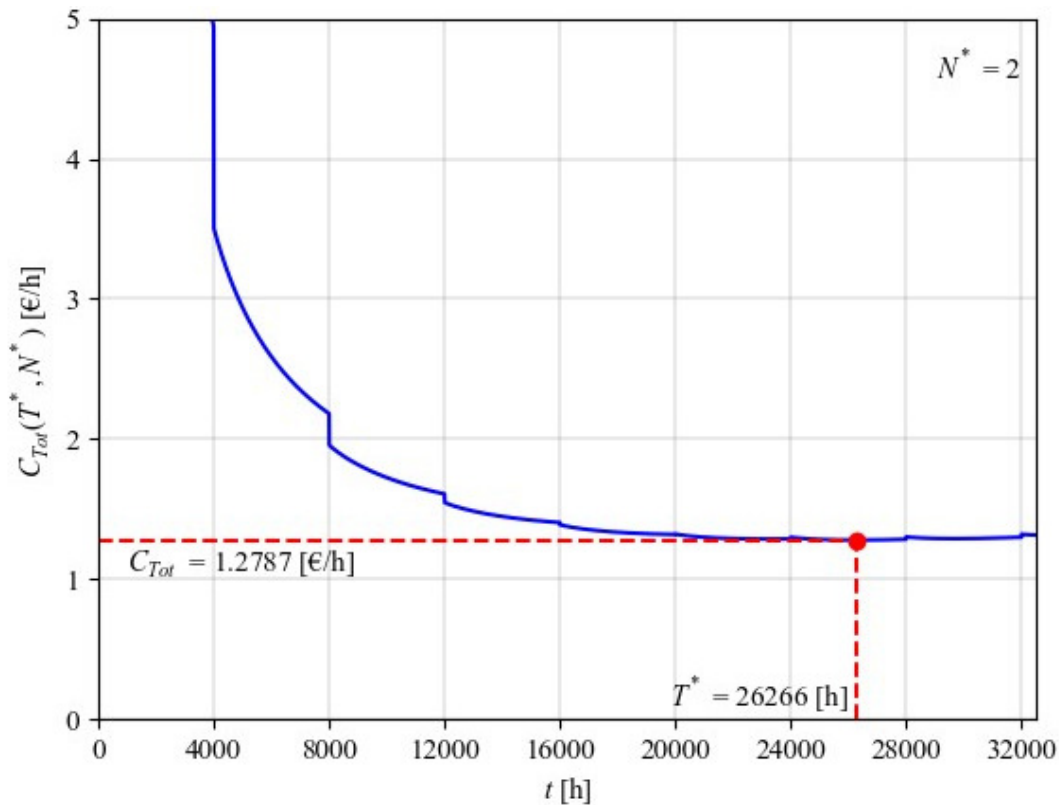

**Figure 37. Cost rate function for ship 1 with  $\alpha = 0.05$**

A scenario with  $\alpha = 0.05$  is shown in Figure 37. and confirms the expected behaviour. As can be seen in Figure 37., the overhaul time that causes the lowest maintenance and spare part costs is extended to  $T^* = 26266$  hours, while the spare part quantity is reduced to  $N^* = 2$  sets. The optimum costs are reduced by 0.236 €/h. The exact opposite scenario with  $\alpha = 0.15$  is shown in Figure 38. It is expected that if the degradation coefficient  $\alpha$  increases above the normal value

assumed for the modelling, the total cost  $C_{Tot}(N^*, T^*)$  increases and the expected major overhaul time  $T^*$  decreases.

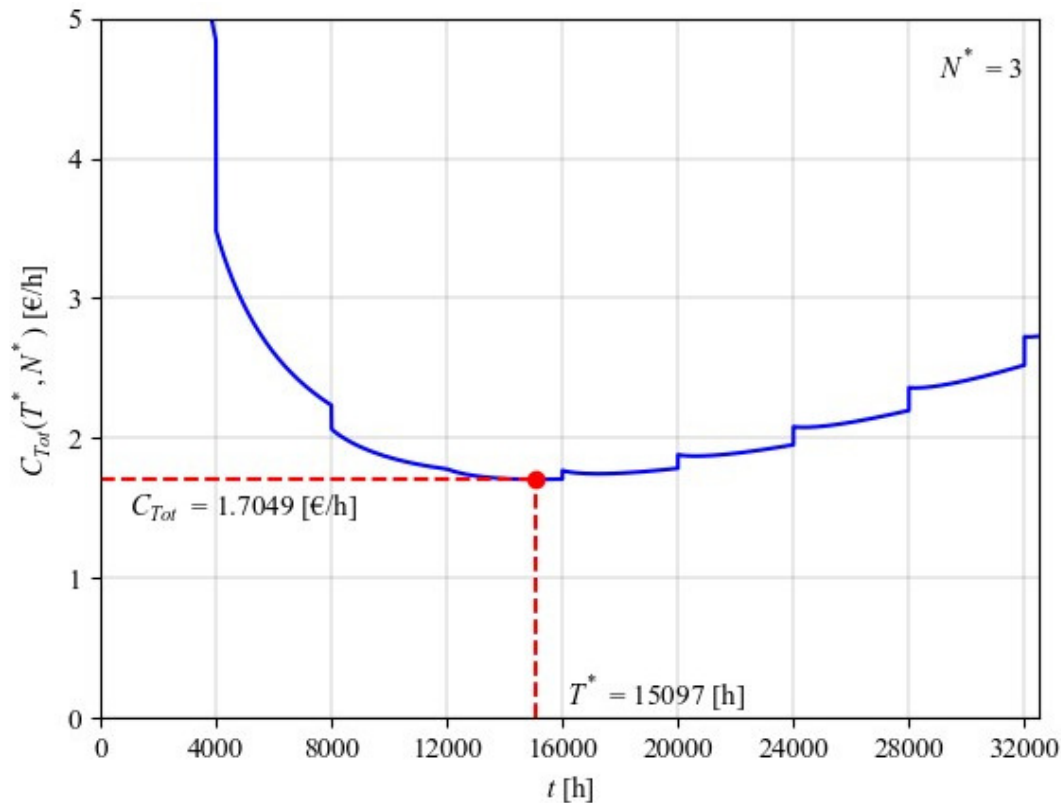

**Figure 38. Cost rate function for ship 1 with  $\alpha = 0.15$**

The results shown in Figure 38. confirm this behaviour, costs increased to  $C_{Tot}(N^*, T^*) = 1.7049$  €/h, while the overhaul time which causes the lowest maintenance and spare part costs was reduced to  $T^* = 15097$  hours.

The optimization results with different degradation coefficients are shown in Table 25.

**Table 25. Changes in the optimization results with changes in  $\alpha$**

Value of $\alpha$	Degradation factor	$C_{Tot}$ [€/h]	$T^*$ [h]	$N^*$
0.001	1.0010	0.85	177772	1
0.01	1.0101	0.9931	58022	1
0.05	1.0513	1.2787	26266	2
0.08	1.0833	1.4319	21978	2
<b>0.1</b>	<b>1.1052</b>	<b>1.5147</b>	<b>18500</b>	<b>3</b>
0.12	1.1275	1.602	17892	3
0.15	1.1618	1.70496	15097	3
0.20	1.2214	1.8876	13777	3
0.30	1,3499	2.1629	11216	4



In the Table 25., the value which is normally used in most optimizations is in bold. Some of these results are already shown above as Figures. The results presented show that this form of sensitivity analysis leads to the expected results. The total costs  $C_{Tot}(N^*, T^*)$  and the quantity of spare parts ordered are proportional to the degradation factor. The values of the major overhaul time  $T^*$ , which cause the lowest maintenance and spare part costs  $C_{Tot}(N^*, T^*)$ , are inversely proportional to the degradation, i.e. the lower the degradation, the longer the overhaul time.

The next step, shown in Figures 39. and 40., is to check the model behaviour using the upper and lower confidence interval limits ( $CI_{UL}$  and  $CI_{LL}$ ) for  $\hat{\beta}^{PLP}$  and  $\hat{\theta}$  calculated in Sections 4.2.3. and 4.2.4. In this case, parameters for optimisation in Figure 39. are  $CI_{LL} = (0.6131, 88714.9077 \text{ h})$ .

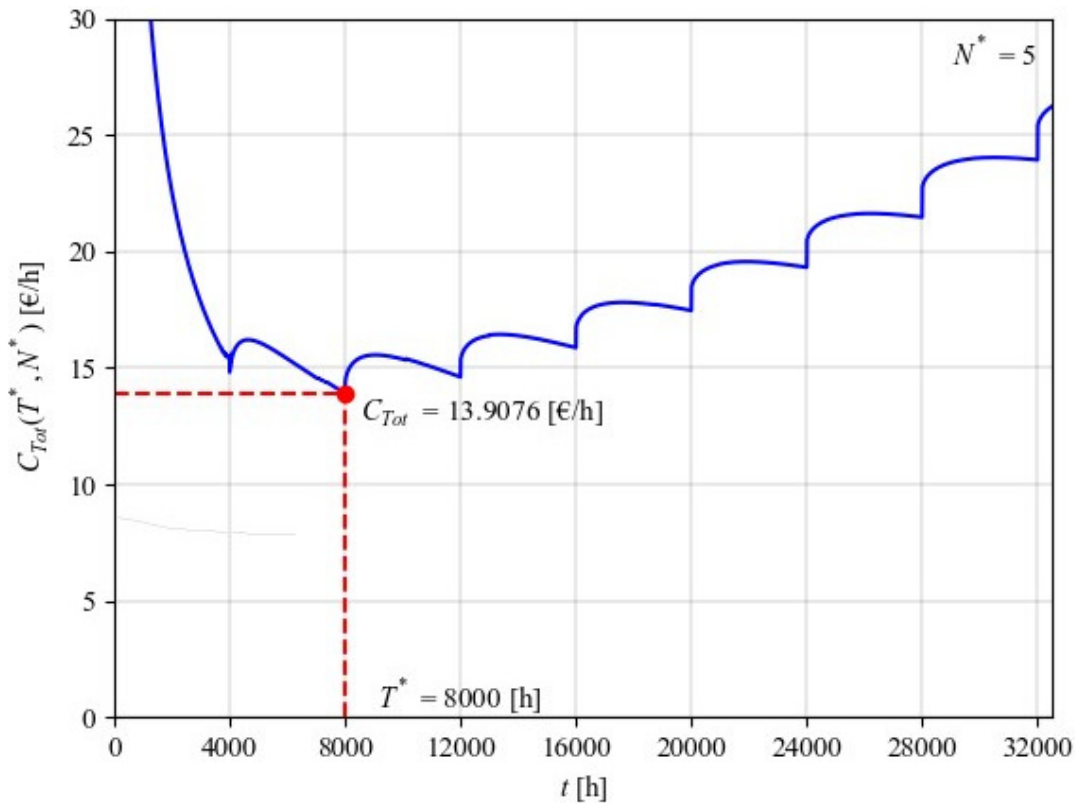

**Figure 39. Cost rate function for ship 1  $CI_{LL} = (0.6131, 88714.9077)$**

If  $CI_{LL}$  are used for the optimization, as shown in Figure 36, the optimal total cost increases to  $C_{Tot}(N^*, T^*) = 13.9076 \text{ €/h}$  for the overhaul performed at  $T^* = 8000$  hours and a spare parts order quantity  $N^* = 5$ . The opposite results are obtained when  $CI_{UL}$  are used in the model. The results with parameters  $CI_{UL} = (2.0534, 3847.7371 \text{ h})$  of this optimization are shown in Figure 40. The optimal total cost decreases to  $C_{Tot}(N^*, T^*) = 0.3761 \text{ €/h}$ , the optimal overhaul time increases to  $T^* = 42578$  hours and the spare parts order quantity decreases to  $N^* = 2$ .

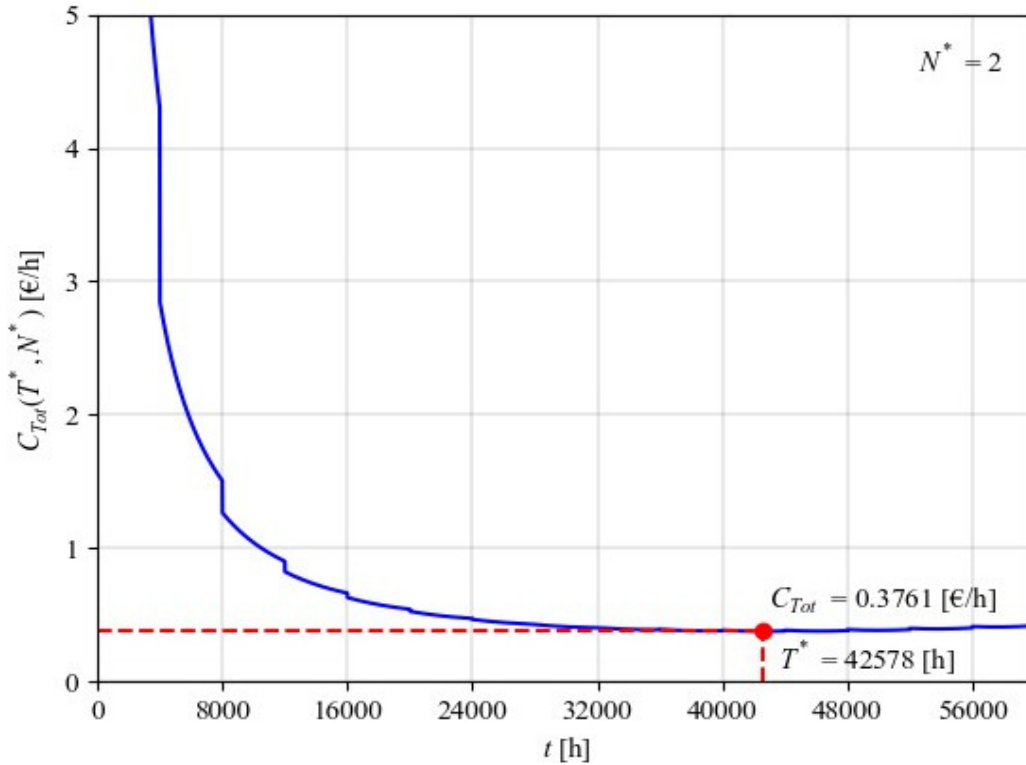

**Figure 40. Cost rate function for ship 1 at  $CI_{UL} = (2.0534, 3847.7371)$**

The results of the sensitivity analysis presented show that the model behaves as expected, i.e. that it delivers the expected results in the areas examined. The first part of the analysis, in which the coefficient  $\alpha$  was changed, showed that the model behaves as expected in the coefficient range of 0.001 - 0.30 (it is stable). From researched literature and from personal life experience, it is assumed that the value of the coefficient  $\alpha$  in a real scenario will be in this range. In the second part of the sensitivity analysis, the behaviour of the model was tested using the upper and lower confidence interval limits ( $CI_{UL}$  and  $CI_{LL}$ ) for  $\hat{\beta}^{PLP}$  and  $\hat{\theta}$ . As in the first case, the model achieves the expected results with the tested values. Since the model behaves as expected for both confidence interval limits, it can be concluded that the model is stable for all expected values of  $\hat{\beta}^{PLP}$  and  $\hat{\theta}$ .

#### 5.3.4. Optimization results for ship 2

The parameters calculated in section 4.2.4 are used to determine the order quantity and preventive maintenance time for ship 2, which minimize the total cost of maintenance and spare parts according to Equation 74. Since they are sister ships, the optimization results of ship 2 are expected to be similar to the results of ship 1. The result of the optimization using the BFM is shown in Figure 41. The optimal costs are slightly higher than the costs of ship 1 and are  $C_{Tot}$

$(N^*, T^*) = 1.5979 \text{ €/h}$ . The optimal major overhaul time  $T^* = 19215$  hours and is also greater than the time for ship 1. The optimal spare parts order quantity is the same as for ship 1.

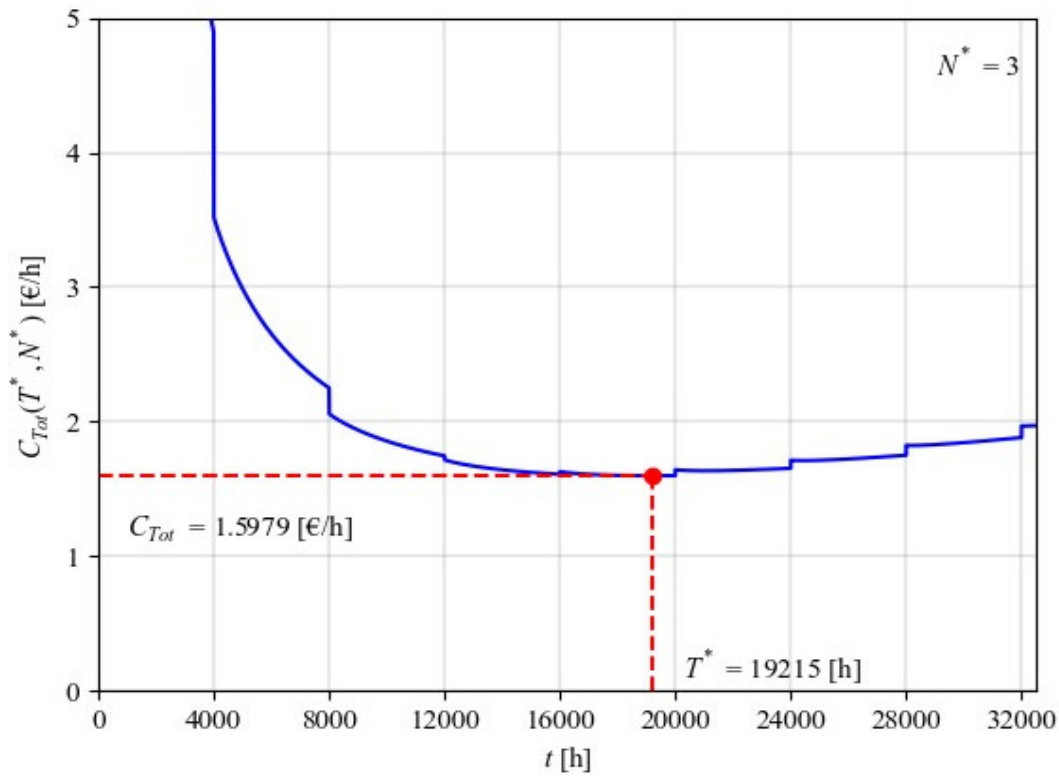

**Figure 41. Cost rate function for ship 2**

Figure 42. shows the relationship between cost and order quantity for ship 2 and confirms the results determined using the BFM.

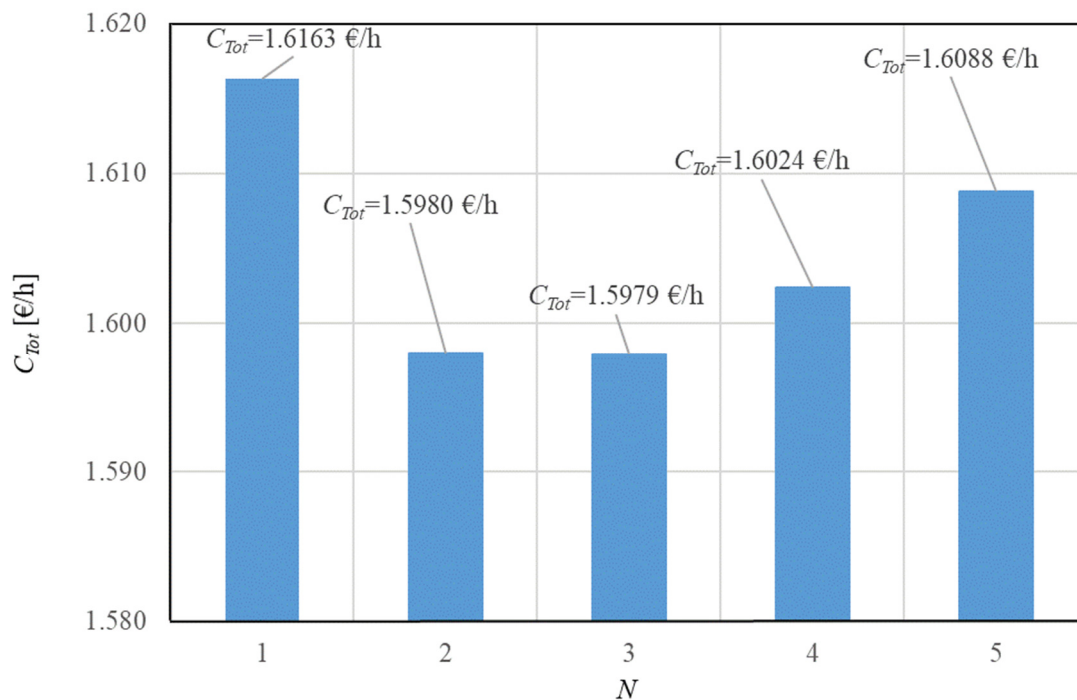
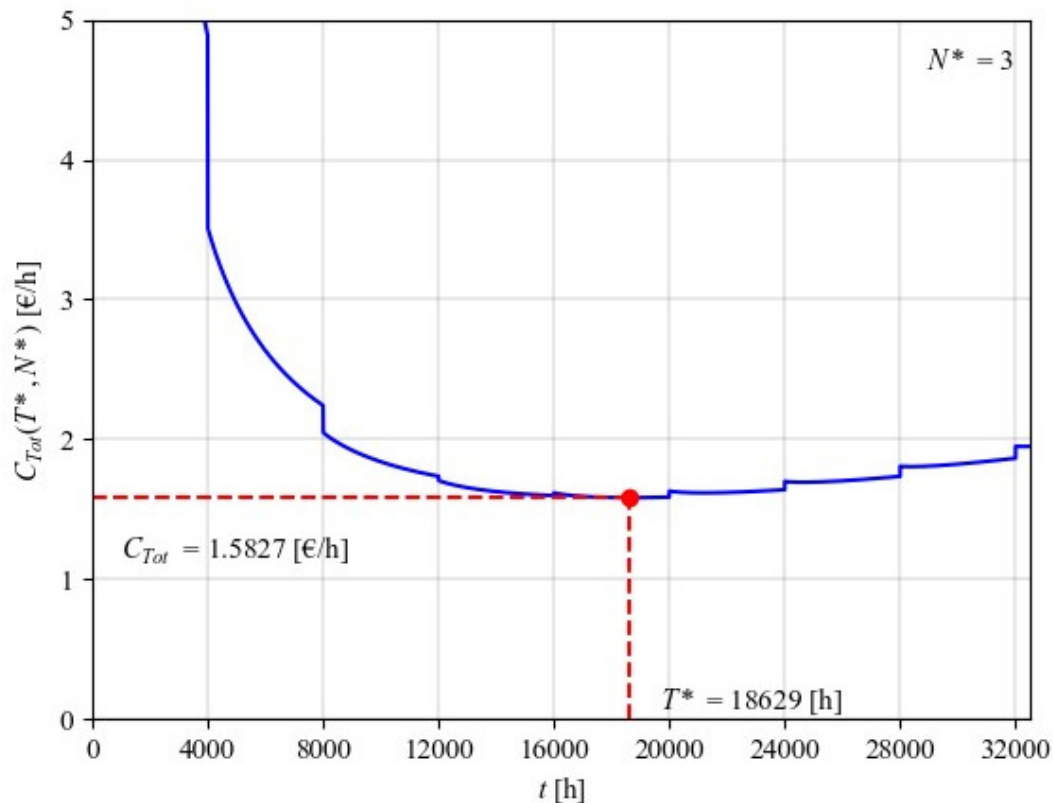

**Figure 42. Costs per unit time for various  $N$  for ship 2**

The values calculated in Figure 42. were calculated using an Excel file; the differences between this calculation and the BFM calculation are again very similar and confirm the results calculated using the BFM.

### 5.3.5. Optimization using both ships parameters

Section 4.2.5. describes how to combine the data from the two sisterships and calculate MLE for  $\beta$  and  $\theta$  for a larger data set making the confidence interval narrower than it was for each individual ship. Figure 43. shows the relationship between  $C_{Tot}(N^*, T^*)$  calculated for the system of the two ships.



**Figure 43. Cost rate function for both ships**

The optimal cost  $C_{Tot}(N^*, T^*) = 1.5827$  €/h, with a  $T^* = 18629$  hours and  $N^* = 3$  sets.

Figure 44. shows the relationship between the costs and the order quantity calculated for the system of the two ships, similar to Figures 35 and 41. The optimal cost value calculated with Excel confirms the results obtained with the BFM.

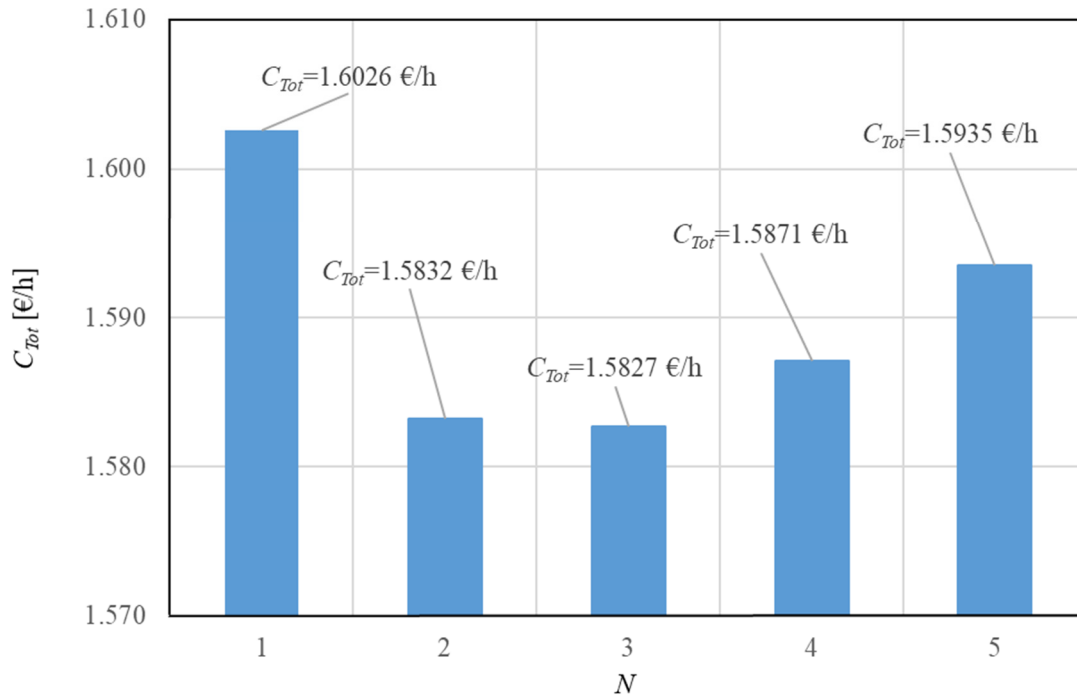

**Figure 44. Costs per unit time for various  $N$  for both ships**

### 5.3.6. Comparison of optimization results

The comparison of all optimization results is shown in Table 26. It can be seen from the Table that the optimization results are quite similar. The size of the spare part order  $N^*$  is exactly the same, while  $C_{Tot}(N^*, T^*)$  and  $T^*$  are slightly different.

**Table 26. Comparison of optimization results**

	$C_{Tot}$ [€/h]	$T^*$ [h]	$N^*$
<b>Ship 1 parameters</b>	1.5147	18500	3
<b>Ship 2 parameters</b>	1.5979	19215	3
<b>Both ships parameters</b>	1.5827	18629	3

Minimal maintenance costs  $C_{Tot}(N^*, T^*)$  are the lowest for ship 1 parameters as well as  $T^*$ . Results for vessel 2 are at the opposite end, while results calculated for two ships are in the middle between two ships.

This comparison has shown that the results obtained are consistent and clear despite the very small differences noted (about 4.5% differences in  $C_{Tot}(N^*, T^*)$  and less than 4% differences in  $T^*$ ).

### 5.3.7. Safety critical spares impact on optimization model

In the last part of section 2.2.3. it is pointed out that the introduction of a new element in the optimization models for maintenance and spare parts in the maritime industry will change the applied inventory policies and lead to changes in the total costs, and that these issues will be discussed later in this document. All optimizations performed so far in the model had the value  $S_{CS} = 2$  and the dividing factor  $p_c = 0.25$  (spreading  $S_{CS}$  purchase costs to maintenance 4 cycles). In the mentioned optimizations, the value of the spare parts shortage costs  $C_{SS}$  was zero. In order to investigate the consequences of introducing  $S_{CS}$  in the maritime industry, the optimization Equation 74 should be modified so that  $S_{CS}$  is zero and the excluded value  $C_{SS}$  (according to Equation 66) is included in the calculation (as shown in Equation 82):

$$\begin{aligned}
C_{Tot} = C_M + C_S = & \\
& \left[ \left[ (C_{MH} \cdot W \cdot h_{CM}) + (C_{Stp} \cdot h_{CM} + C_{Fai} + C_{Dam}) + C_{CMC} + C_{CME} \right] \cdot \right. \\
& \left. \cdot H(T) \cdot \frac{(e^{\alpha K} - 1)}{(e^{\alpha} - 1)} + \right. \\
= \frac{N_u}{\sum_{i=1}^K T_i} \cdot & \left. \left[ (C_{MH} \cdot W \cdot h_{PMi}) + (C_{Stp} \cdot h_{PMi} \cdot P_{PMi}) + C_{PMiC} \right] (K-1) + \right. \\
& \left. \left[ (C_{MH} \cdot W \cdot h_{PMp}) + (C_{Stp} \cdot h_{PMp} \cdot P_{PMp}) + C_{PMpC} \right] \right] + \\
& + \frac{\left[ N_{CM} + N_{PMi} (K-1) + N_{PMp} + \cancel{S_{CS}} \cdot p_c \right] \cdot C_{Spa}}{\sum_{i=1}^K T_i \cdot N} + \\
& + \frac{(C_{Han} + C_{Cus}) \cdot \left[ N_{CM} + N_{PMi} (K-1) + N_{PMp} + \cancel{S_{CS}} \cdot p_c \right]}{\sum_{i=1}^K T_i} + \\
& + \left[ \left( \frac{N}{2} + S_S + \cancel{S_{CS}} \right) \cdot C_{Hol} + C_{SS} \right]
\end{aligned} \tag{84}$$

Figure 45. shows the diagram of the minimum maintenance costs  $C_{Tot} (N^*, T^*)$  for ship 1 of 1.469 €/h for the situation in which there is no minimum of safety critical spare parts, i.e.  $S_{CS}$  equals 0. Comparing Figure 45. with Figure 35., where  $S_{CS}$  equals 2, a reduction of the

calculated costs  $C_{Tot}(N^*, T^*)$  by 0.0457 €/h can be seen. At the same time, there is a reduction in  $T^*$  of 68 hours while there is no change in spare parts order quantity  $N^*$ .

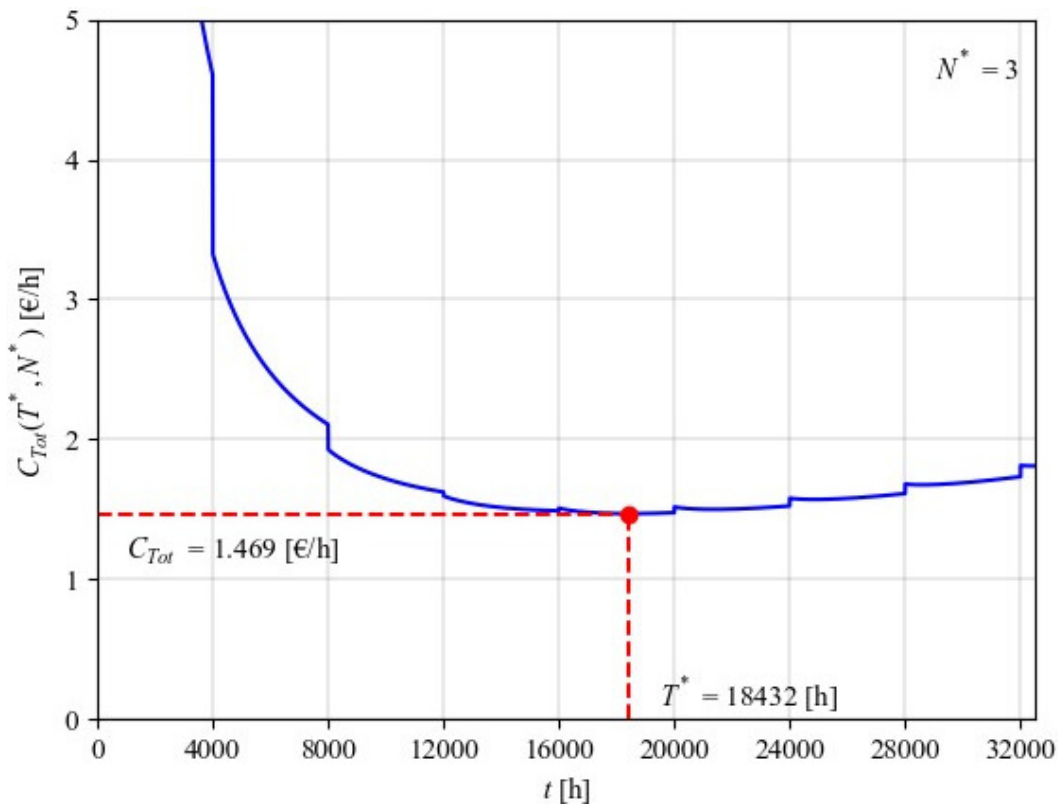

**Figure 45. Cost rate function for ship 1 without  $S_{CS}$**

Based on this first impression, it can be seen that the average costs per hour are lower without  $S_{CS}$  and that the introduction of this new limit causes additional costs for the shipping company. Often these quick conclusions and impressions are not reliable and can very quickly turn out to be wrong. In this model, there is another parameter which includes the cost of spare parts shortage, i.e. the costs caused by the lack of spare parts and the inability to perform corrective maintenance when needed. In the optimization shown in Figure 45., it is assumed that the lack of spare parts after the failure does not cause any additional costs for the ship ( $C_{SS} = 0$ ), e.g. costs due to reduced ship speed or delay in arrival at port or similar costs.

If these costs are included ( $C_{SS} > 0$ ), the situation changes and new findings may emerge that could change the initial opinion. Table 27. shows the relationship between spare part shortage costs and the increase in total costs for ship. This calculation assumes that one undesirable spare part shortage occurs per major overhaul cycle, causing the total shortage costs shown in the corresponding column. The first line of the table shows the normal operating costs with  $S_{CS}$  and without  $C_{SS}$ . The second row shows the costs without  $S_{CS}$  and  $C_{SS}$ , i.e. the scenario shown in Figure 45.

**Table 27. Spare parts shortage costs analysis for ship 1**

$S_S$	$C_{SS}$ (€)	$C_{Tot}$ [€/h]	$T^*$ [h]	$N^*$
<b>2</b>	<b>0</b>	<b>1.5147</b>	<b>18500</b>	<b>3</b>
0	0	1.469	18432	3
0	100	1.4744	18432	3
0	200	1.4798	18432	3
0	400	1.4907	18432	3
0	600	1.5015	18432	3
<b>0</b>	<b>843</b>	<b>1.5147</b>	<b>18432</b>	<b>3</b>
0	900	1.5178	18432	3
0	1200	1.5341	18432	3
0	1500	1.5503	18432	3
0	2000	1.5775	18432	3

These costs are followed by the costs with different spare parts shortage costs, from the lowest to the highest. According to the data presented,  $C_{Tot}(N^*, T^*)$  increases together with the total shortage costs (as expected, which confirms that the model also works correctly in this respect).

Figure 46. shows the average costs identical to the costs in Figure 35.

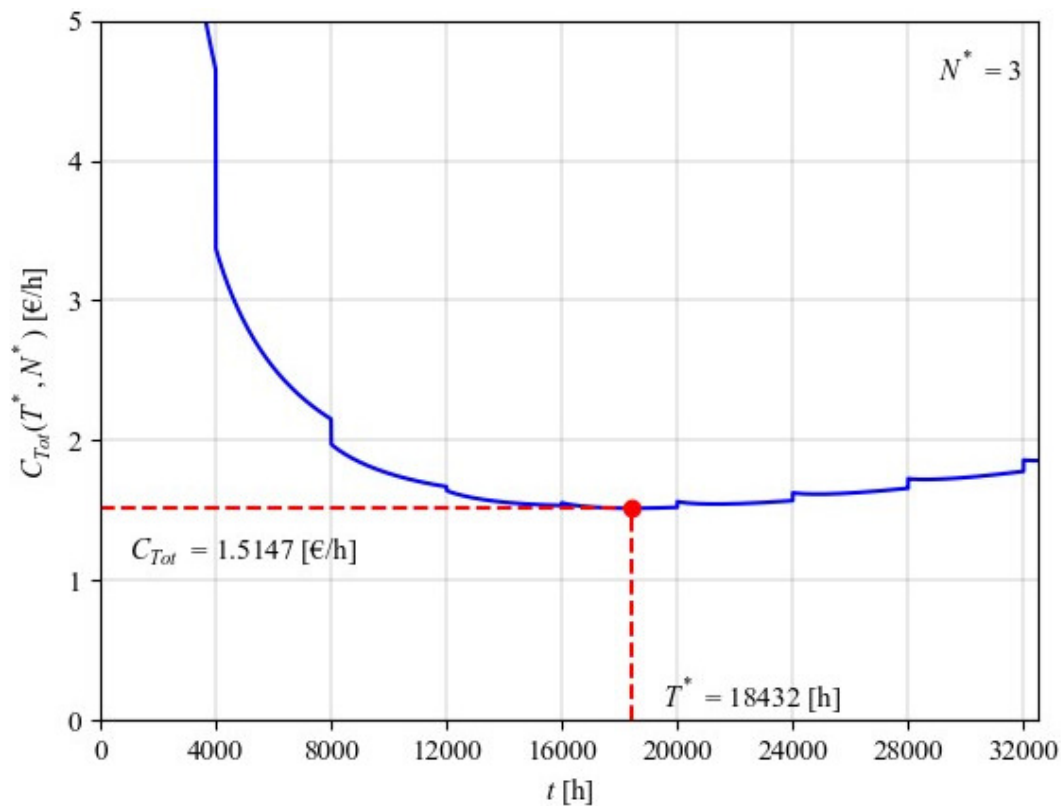
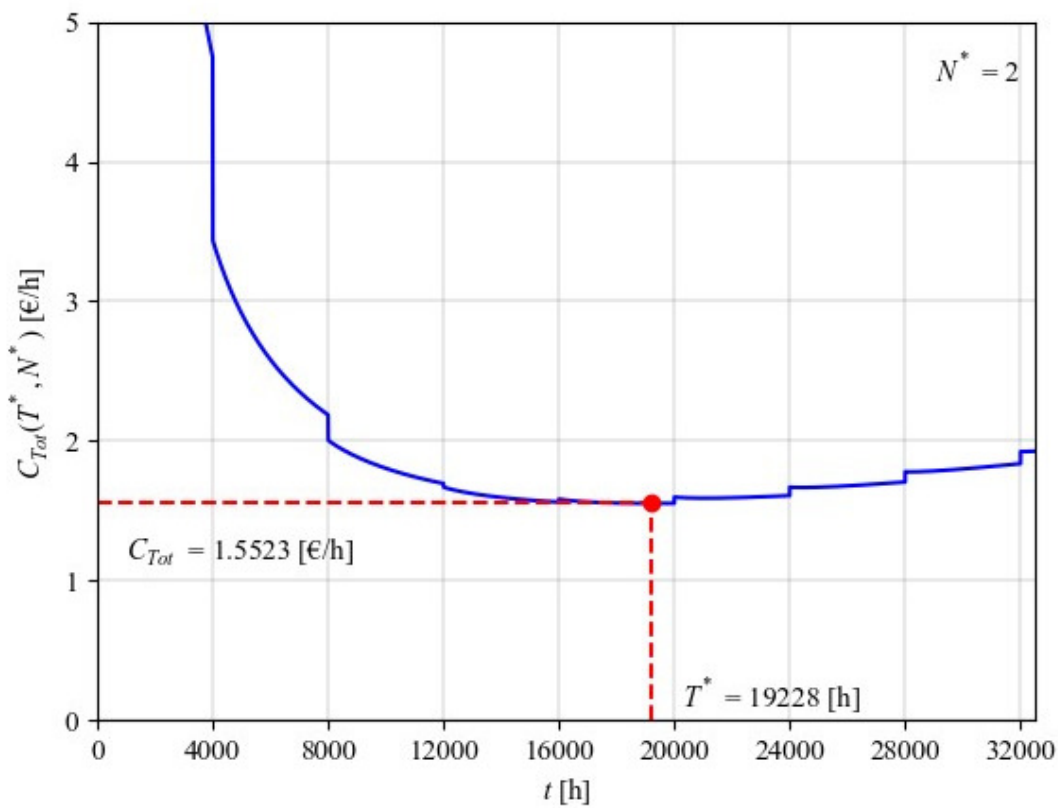

**Figure 46. Cost rate function for ship 1 without  $S_{CS}$  and with  $C_{SS} = 843$  [€]**



In this case, the cost without safety critical spare parts and a spare part shortage amounted to exactly  $C_{SS} = 843 \text{ €}$  created  $C_{Tot}(N^*, T^*) = 1.5094 \text{ €/h}$  which is the same value presented in Figure 35. With a further increase in the value of  $C_{SS}$ , the value of  $C_{Tot}(N^*, T^*)$  increases more and more.

Figure 47. shows the diagram of the minimum maintenance costs minimal expected costs for unit time od for ship 2 of  $C_{Tot}(N^*, T^*) = 1.5523 \text{ €/h}$  for the situation in which there is no minimum of safety critical spare parts, i.e.  $S_{CS} = 0$ . Comparing Figure 47. with Figure 41., where  $S_{CS} = 2$ , a reduction of the calculated costs  $C_{Tot}(N^*, T^*)$  by  $0.0456 \text{ €/h}$  can be seen, which is almost the same as the amount calculated for ship 1.



**Figure 47. Cost rate function for ship 2 without  $S_{CS}$**

At the same time,  $T^*$  is increased by 15 hours and the spare parts order quantity is reduced to  $N^* = 2$ .

Table 28. shows the relationship between spare part shortage costs and the increase in total costs for ship 2, assuming that the undesirable event (shortage) occurs once per major overhaul cycle.

**Table 28. Spare parts shortage costs analysis for ship 2**

$S_S$	$C_{SS}$ (€)	$C_{Tot}$ [€/h]	$T^*$ [h]	$N^*$
<b>2</b>	<b>0</b>	<b>1.5979</b>	<b>19215</b>	<b>3</b>
0	0	1.5523	19228	2
0	100	1.5575	19228	2
0	200	1.5627	19228	2
0	400	1.5731	19228	2
0	600	1.5835	19228	2
<b>0</b>	<b>876</b>	<b>1.5979</b>	<b>19228</b>	<b>2</b>
0	900	1.5992	19228	2
0	1200	1.6148	19228	2
0	1500	1.6304	19228	2
0	2000	1.6564	19228	2

Same as in Table 27, the data presented in this Table also shows that  $C_{Tot}$  ( $N^*$ ,  $T^*$ ) increases together with the total shortage costs. Figure 48. shows the average costs  $C_{Tot}$  ( $N^*$ ,  $T^*$ ), which are identical to the costs in Figure 41.

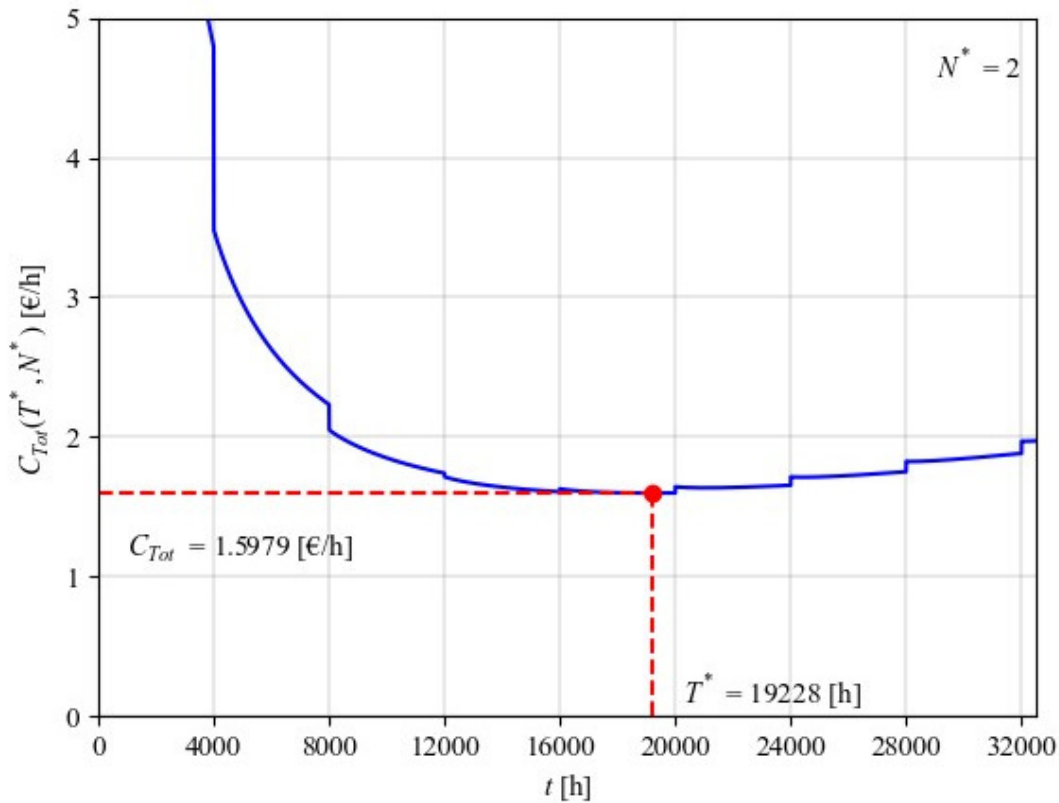

**Figure 48. Cost rate function for ship 2 without  $S_{CS}$  and with  $C_{SS} = 876$  [€]**

In this case, the cost without safety critical spare parts and with an unwanted event (spare part shortage) amounted to exactly  $C_{SS} = 876 \text{ €}$  created  $C_{Tot}(N^*, T^*) = 1.5979 \text{ €/h}$ . With a further increase in the value of  $C_{SS}$ , the value of  $C_{Tot}(N^*, T^*)$  increases more and more.

Finally, the optimization of the scenario without  $S_{CS}$  is carried out with the parameters calculated for both ships. The results can be seen in Figure 49. and show a reduction of  $C_{Tot}(N^*, T^*)$  by  $0.0457 \text{ €/h}$ , which is exactly the amount calculated for ship 1. The spare parts order quantity remained the same while the time for the major overhaul is reduced by 91 hours.

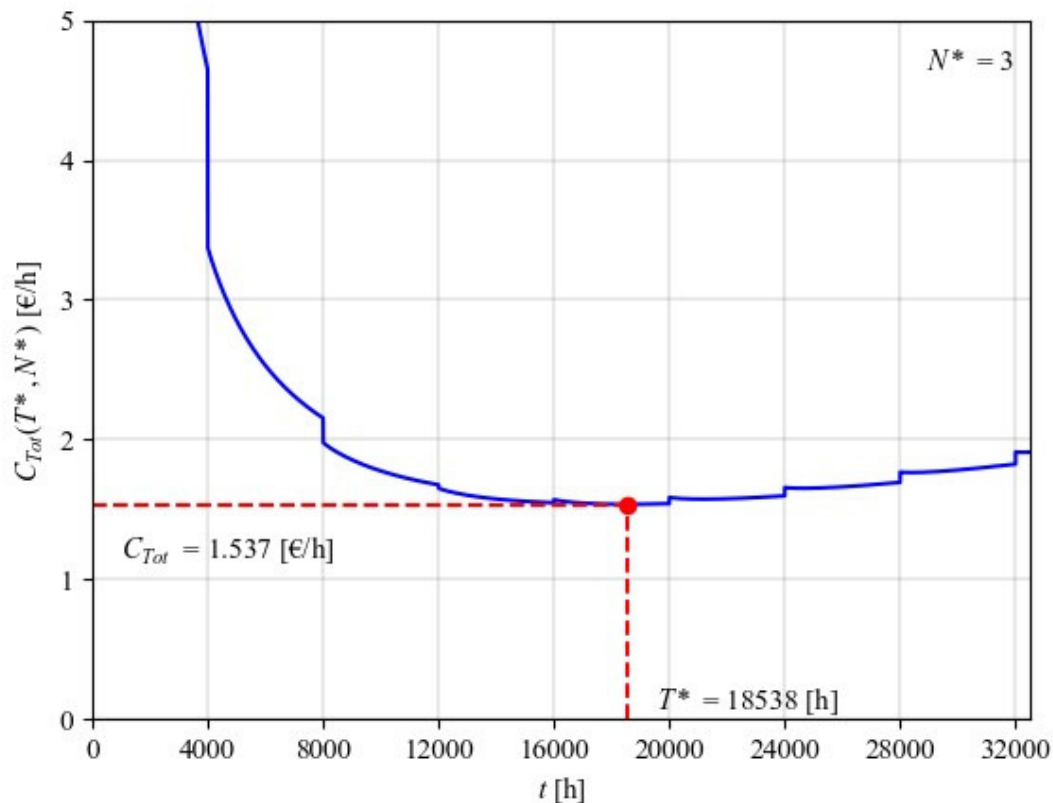

**Figure 49. Cost rate function time for both ships without  $S_{CS}$**

This analysis shows that the cost of maintaining an additional quantity of spare parts on board (in the form of  $S_{CS}$ ) is worthwhile even if only a single undesirable consequence of the failure is prevented (and especially with relatively low shortage costs as in this case) during a major overhaul period. The value of the additional level of safety of the ship, cargo, crew and environment that these parts provide is impossible to measure.

## 6. VALIDATION OF THE MODEL

Validation is one of the key elements in reviewing any proposed change to ensure that the proposal meets the design requirements. In this thesis, there are several points that need to be verified and validated. The first part of the verification has already been done and presented in Sections 4.3. and 4.4., where the applicability of the proposed changes was checked.

The next step was to verify that the model works as intended under different scenarios. For this purpose, a complex sensitivity analysis was performed, the results of which are described in section 5.3.3.

The first part of the validation presented in this chapter is done by solving Equation 74 in such a way that the parameter  $H(T)$  is calculated using the Weibull method according to Equation 35 (instead of the PLP calculation in Equation 36), and at the end the optimization results are validated in a process where the function defined by Equation 74 is optimized and solved using another (well-established) optimization method. The advantages of the Python programming language mentioned in the last line of the paragraph in Section 3.7., are fully utilized here. A search in the SciPy documentation [190] found ready-made codes for two optimization methods that are used to check the results obtained with BFM. These two methods are the Brent's method [31, 32] and the L-BFGS-B method [33, 34], and both methods have been used to verify the BFM.

The fact that the BFM is slow and unsuitable for complex calculations [36, 37, 187, 188] is revisited and the results are presented in this Section with a personal prediction about the applicability of the BFM in the future.

### 6.1. OPTIMIZATION USING WEIBULL CALCULATION

The final confirmation that the optimization Equation (Equation 74) and the application of the PLP method are correct is obtained by solving the Equation with the parameter  $H(T)$  (mean number of failures on the interval) determined using the Weibull method. For this purpose, the Weibull MLE parameters shown in Table 16. are used for ship 1 and in Table 18. for ship 2. After optimization with these parameters, a comparison of the two calculations, PLP and Weibull, is performed to verify the overall results. The calculation of  $H(T)$  using the Weibull method is described by several already mentioned authors, [117, 156 – 158], and it will be performed using Equation 36. Figure 53. shows the optimization using the Weibull parameters for ship 1, calculated in Section 4.3.1. to  $\beta_w = 2.0129$  and  $\eta = 34263.9$ . The figure

presents calculation of  $C_{Tot}(N^*, T^*) = 1.6925 \text{ €/h}$  with  $T^* = 17972$  hours of operation and optimal spare parts order of  $N^* = 3$  sets.

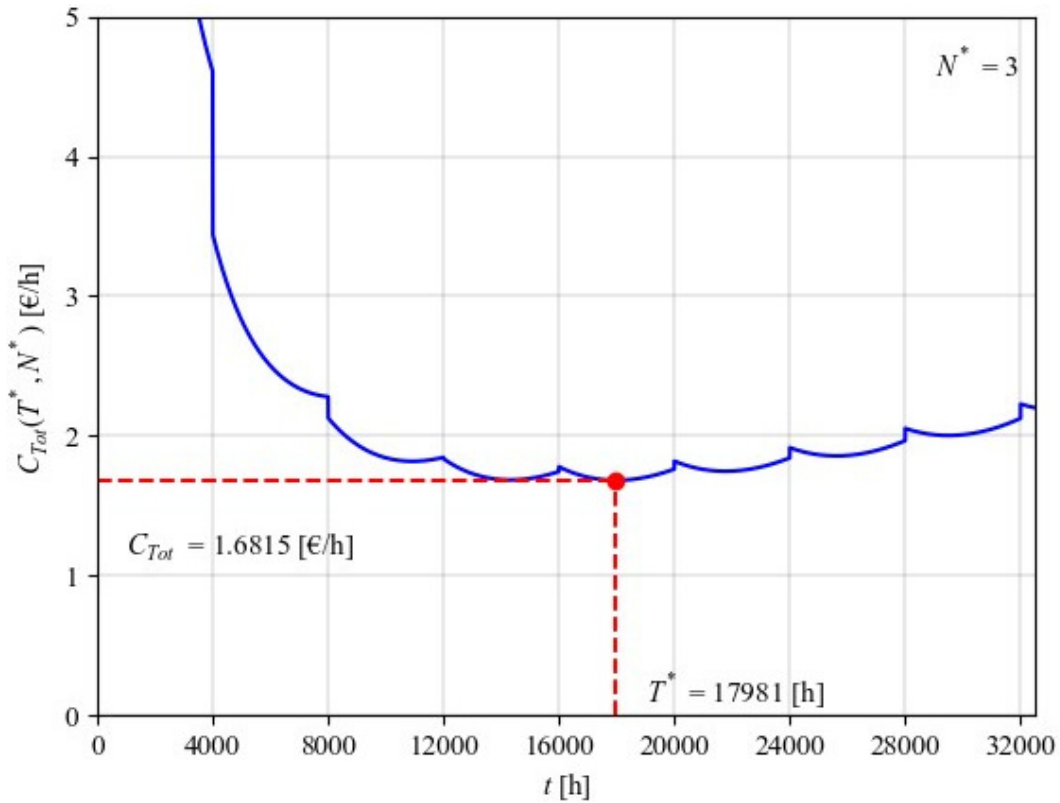

**Figure 50. Cost rate function for ship 1 calculated using Weibull method**

The comparison of total costs for different  $N$  for ship 1 using the Weibull method is shown in Figure 51 which confirms results presented in Figure 50.

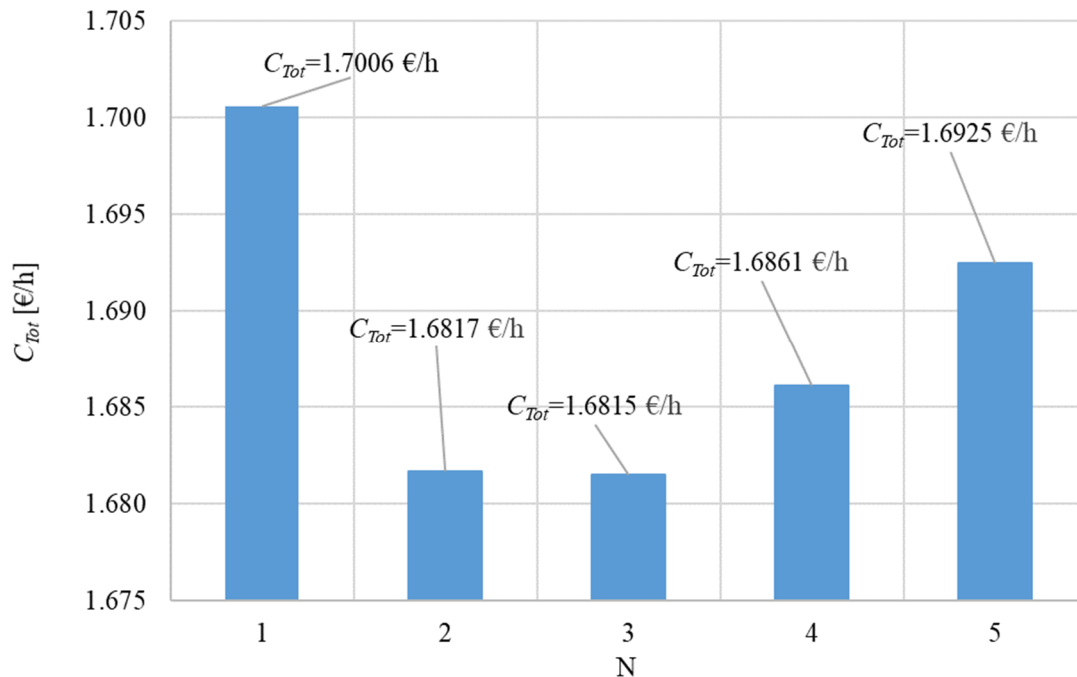

**Figure 51. Costs for various  $N$  for ship 1 calculated using Weibull**

The same calculation is performed for ship 2 and presented in Figures 52. and 53. Figure 52. shows calculation of  $C_{Tot}(N^*, T^*) = 1.4881 \text{ €/h}$  with  $T^* = 18029$  hours and  $N^* = 3$ .

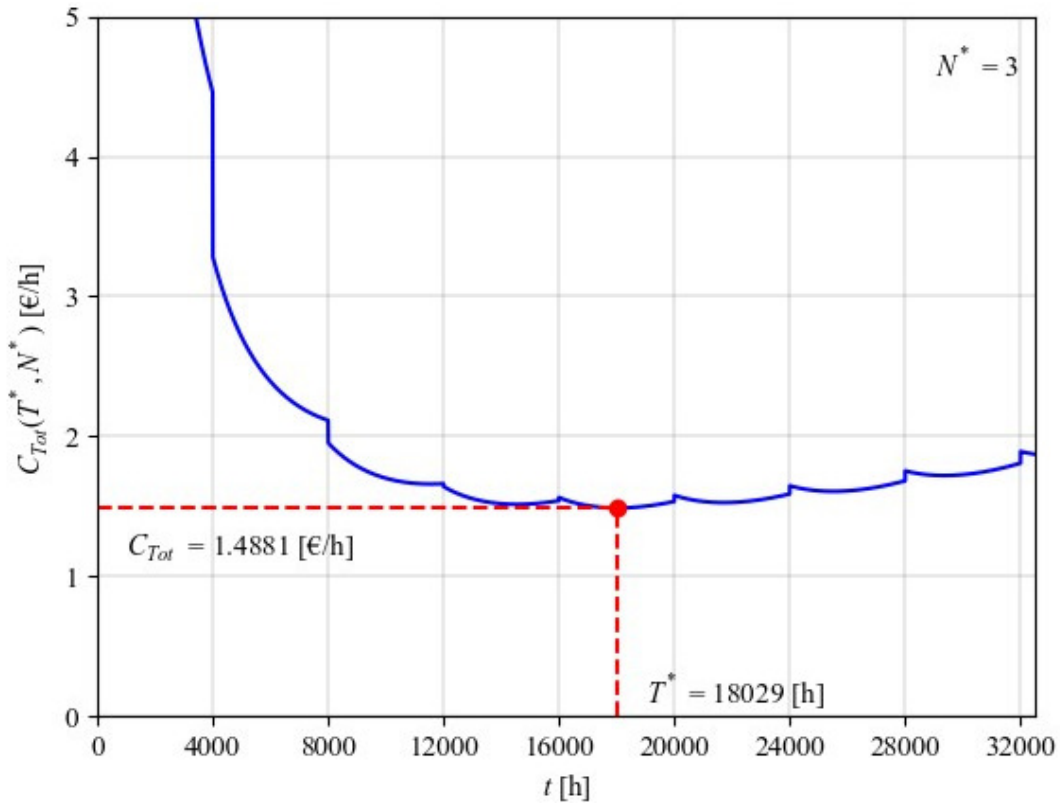

**Figure 52. Cost rate function for ship 2 calculated using Weibull method**

The comparison of total costs for different  $N$  for ship 2 using the Weibull method is shown in Figure 53.

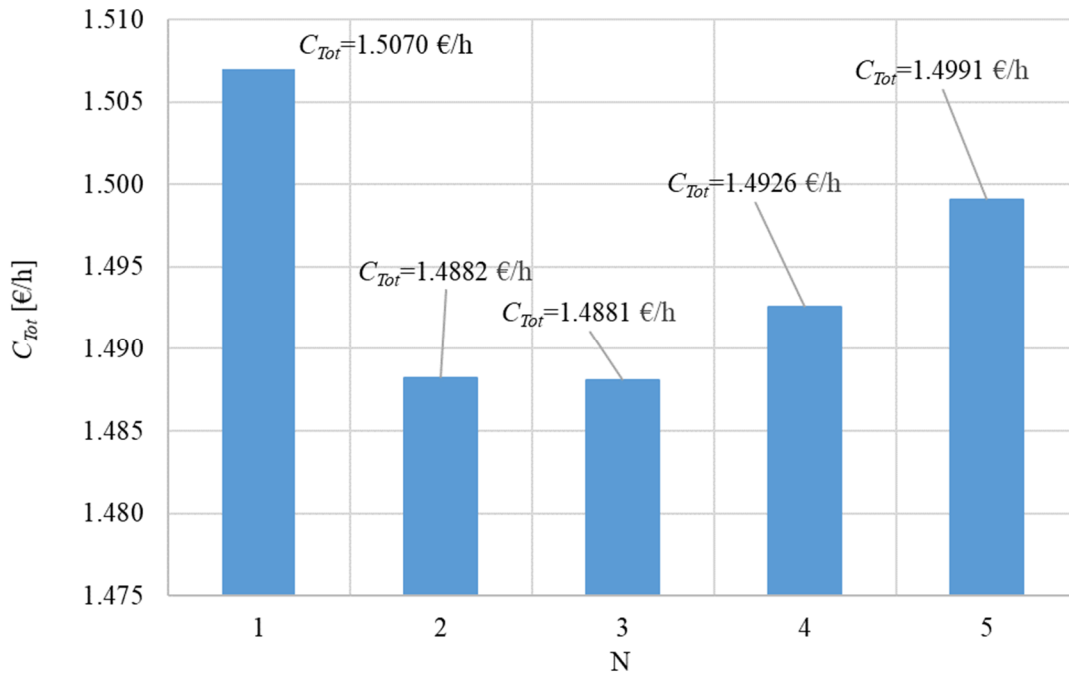

**Figure 53. Costs for various  $N$  for ship 2 calculated using Weibull**

This calculation confirms the result shown in Figure 53. that the minimum  $C_{Tot}$  ( $N^*$ ,  $T^*$ ) is for  $N = 3$ . This calculation shows a similar behaviour as in Figure 36., Figure 42. and Figure 51. where the highest minimum of the cost rate function is calculated for  $N = 1$  and where the minima for  $N = 2$  and  $N = 3$  are very close to each other. The values increase again from  $N = 4$ .

A comparison of the optimization results achieved by PLP and Weibull is shown in Table 30.

**Table 29. PLP and Weibull optimization results comparison**

	PLP			Weibull		
	$C_{Tot}$ [€/h]	$T^*$ [h]	$N^*$	$C_{Tot}$ [€/h]	$N^*$	$T^*$ [h]
<b>Ship 1 parameters</b>	1.5147	18500	3	1.6815	3	17981
<b>Ship 2 parameters</b>	1.5979	19215	3	1.4881	3	18029
<b>Both ships</b>	1.5827	18629	3	/	/	/

A comparison of the results reveals a considerable similarity between the results. The optimal quantity of spare parts calculated with both methods is completely the same for all sets of MLE parameters. The recommended major overhaul times for Weibull method are lower than times calculated by PLP method with maximum difference of 7% which is quite low. The difference in the minimal costs is also limited, with the largest deviation being 11%, which is acceptable given the sample size and the margin of error. When comparing only the results obtained with the Weibull method, it can be seen that the range of results is wider than with the PLP method. This wider range of results points to the same conclusion reached with the AICc method, namely that the PLP method is more suitable for this data set than the Weibull method and should be used in such cases.

## 6.2. RECHECKING BRUTE FORCE METHOD RESULTS

The first method used to check the optimization results with the BFM is Brent's method. This is a method that combines root bracketing, bisection and inverse quadratic interpolation to converge from the neighbourhood of a zero crossing. It was developed in the 1960s by van Wijngaarden, Dekker and others at the Mathematical Centre in Amsterdam and later improved by Brent [31]. The Brent's method has the sureness of bisection and the speed of a higher order method [32] and is highly recommended as a fast and reliable method for solving mainly one-dimensional optimization problems.

The Brent's method has many advantages and disadvantages compared to other optimization methods. The advantages include that the function need not need to be

differentiable, that the method guarantees convergence to a root (if one exists), that it can easily find multiple roots, that it can easily handle function discontinuities, and that it has the best properties of the root finding algorithms [200]. In addition to a number of advantages, this method also has disadvantages, such as that the method can be computationally intensive and slower than other methods for larger problems, and that it may require extensions and/or adaptations to solve more complex problems [200].

The code for the Brent's method is available in SciPy [190] and can easily be used to solve one-parameter optimization problems. Due to this property of the method (solving one-parameter optimization problems) and the fact that the optimization defined by Equation 74 is a two-parameter optimization, the Brent's method could not be applied directly without an extension. Therefore, a small modification of the method was made. Since the values of the second variable  $N$  are very low (setting range from 1 to 20; even if  $N^*$  is expected to be in a range of 3-5), the Brent's method was modified to search for the best solution out of 20 (the method performed  $N$  one-parameter optimizations and chose the best solution).

Since the initial verification of the BFM optimization was performed using a modified Brent's method (without verification of the modification and with a lack of confidence in it), an additional verification was performed using a different, verified method for multi-parameter optimization. The method chosen for this task is the Limited memory Broyden–Fletcher–Goldfarb–Shanno method with Boundaries (L-BFGS-B method) [33, 34]. This method is an iterative optimization algorithm from the family of quasi-Newton methods, which is widely used in computer graphics and general scientific computing [34, 201]. This method has some serious advantages, such as the code is easy to use and verify, the user can determine the memory size and thus the computational speed, the method is not computationally intensive when  $N$  is large and is therefore well suited for large problems, the method usually does not require extensions and/or modifications to adapt it to different problems, and it is extremely fast and accurate and can be installed on multiple computers and run in parallel [33, 34, 201]. The method also has some drawbacks, such as problems with parallel implementation of L-BFGS-B on GPUs (Graphics Processing Units) and that difficult problems may require a large number of function evaluations to converge [33, 34, 201].

The code for the L-BFGS-B method is also available in SciPy and was used without modification to solve this optimization.

The optimization results with all three methods for different parameter sets (for ship 1, for ship 2 and for the system) are shown in Figures 54, 55 and 56.



[ BRUTE ] Minimum of 1.5147086774 found at 18500 & 3  
 [ BRENT ] Minimum of 1.5147086770 found at 18500 & 3  
 [L-BFGS-B] Minimum of 1.5147086770 found at 18500 & 3

**Figure 54. Optimization results of ship 1 using three methods**

[ BRUTE ] Minimum of 1.5979016383 found at 19215 & 3  
 [ BRENT ] Minimum of 1.5979016383 found at 19215 & 3  
 [L-BFGS-B] Minimum of 1.5979016383 found at 19215 & 3

**Figure 55. Optimization results of ship 2 using three methods**

[ BRUTE ] Minimum of 1.5827398404 found at 18629 & 3  
 [ BRENT ] Minimum of 1.5827398403 found at 18628 & 3  
 [L-BFGS-B] Minimum of 1.5827398403 found at 18628 & 3

**Figure 56. Optimization results of Both ships using three methods**

A comparison of optimization results with different optimization methods from figures above is shown in Table 29.

**Table 30. Comparison of BFM, Brent's and L-BFGS-B results**

	Ship 1			Ship 2			Both ships		
	$C_{Tot}$ [€/h]	$N^*$	$T^*$ [h]	$C_{Tot}$ [€/h]	$N^*$	$T^*$ [h]	$C_{Tot}$ [€/h]	$N^*$	$T^*$ [h]
<b>BFM</b>	1.5147086774	3	18500	1.5979016383	3	19215	1.5827398404	3	18629
<b>Brent's</b>	1.5147086770	3	18500	1.5979016383	3	19215	1.5827398403	3	18628
<b>L-BFGS-B</b>	1.5147086770	3	18500	1.5979016383	3	19215	1.5827398403	3	18628

Table 29. shows that the results obtained with the three different methods are almost identical, differences are visible to the tenth decimal place or even further in the  $C_{Tot}$  ( $N^*$ ,  $T^*$ ), the calculated spare part order quantities are exactly the same, and the calculated time of the major overhaul differs by 1 hour for the both ships calculation. Since the difference can only be observed in an extremely small ranges, it can be concluded that the results calculated using the BFM are correct.

### 6.3. RESTRICTIONS ON BRUTE FORCE METHOD USAGE

Section 3.7. states that the BFM is used for simpler optimizations with a limited number of operations and a limited number of variables, as it requires a large computational capacity. Furthermore, Section 3.7. states that these problems will decrease with the development of better computers. To test and confirm this assertion, the optimization Equation 74 was solved on three different computers whose specifications are listed in Table 31. To compare the BFM speed with other methods, the BFM computation times are compared with the times of two other methods: Brent’s method and L-BFGS-B method.

It can be seen that computer 1 is an old computer with a 4<sup>th</sup> generation i3 processor, while computers 2 and 3 are both have 11<sup>th</sup> generation processors but with different specifications. Computer 2 has an i5 processor, while computer 3 has an i7. The processing speed of computer 3 is higher, although computer 2 has a larger RAM (Random access memory).

**Table 31. Computer specifications**

	Processor	RAM	OS	Date
<b>Computer 1</b>	Intel(R) Core i3-4030U, 1.90GHz	4 GB, 1600 MHz	Ubuntu 22.04	10/2014
<b>Computer 2</b>	Intel(R) Core i5-1135G7, 2.40 GHz	24 GB, 3200 MHz	Windows 10 Pro	09/2021
<b>Computer 3</b>	Intel(R) Core i7-1185G7, 3.00 GHz	16 GB, 4267 MHz	Ubuntu 22.04	08/2021

Another important point is the computer's operating system. Computers 1 and 3 are running Ubuntu 22.04, while computer 2 is running Windows 10 Pro. In this case, it is important to emphasise that the Windows operating system puts much more load on the hardware than Ubuntu (even up to 20 times), and finally that it slows down the computer.

The computer speed was measured using the optimization Equation 74. and the PLP failure analysis method using the data for ship 1. The performance results of the optimization of ship 1 with Computer 1 are shown in Figure 57.

[ BRUTE ] Minimum of 1.5147086774 found at 18500 & 3 in 79628.8325 ms  
 [ BRENT ] Minimum of 1.5147086770 found at 18500 & 3 in 34.6775 ms  
 [L-BFGS-B] Minimum of 1.5147086770 found at 18500 & 3 in 16.0570 ms

**Figure 57. Speed of different optimization methods on computer 1**

The same problem was solved on the computer seven years younger, and the computer speed test results are shown in Figure 58.

[ BRUTE ] Minimum of 1.5147086774 found at 18500 & 3 in 41751.3468 ms  
 [ BRENT ] Minimum of 1.5147086770 found at 18500 & 3 in 21.6374 ms  
 [L-BFGS-B] Minimum of 1.5147086770 found at 18500 & 3 in 11.3420 ms

**Figure 58. Speed of different optimization methods on computer 2**

Finally, the optimization equation is computed on a professional machine that is the same age as computer 2, only with better optimised components. The results are shown in Figure 59.

[ BRUTE ] Minimum of 1.5147086774 found at 18500 & 3 in 35627.7086 ms  
 [ BRENT ] Minimum of 1.5147086770 found at 18500 & 3 in 17.9666 ms  
 [L-BFGS-B] Minimum of 1.5147086770 found at 18500 & 3 in 10.6674 ms

**Figure 59. Speed of different optimization methods on computer 3**

Figures 57., 58. and 59. show that all three methods solved the problem and arrived at almost the same results, but the difference in computing time is enormous, both between the speed of the computer and the speed of the chosen methods. The comparison of the computing speeds of the different methods and computers is shown in Table 32.

**Table 32. Comparison of computational times**

	<b>BFM [ms]</b>	<b>Brent's Method [ms]</b>	<b>L-BFGS-B Method [ms]</b>
<b>Computer 1</b>	79628.8325	34.6775	16.0570
<b>Computer 2</b>	41751.3468	21.6374	11.3420
<b>Computer 3</b>	35627.7086	17.9666	10.6674

As early as 1965, Gordon E. Moore established a rule that is now known as Moore's Law [202] and states that the speed and performance of computers doubles every two years. Analysing the table above, this law cannot be confirmed, although it can be seen that there has been considerable progress in computing time. The following reductions can be observed between computers 1 and 2 (the age difference is about 7 years):

- The computing time of the BFM is reduced by more than 47%.
- The computing time of the Brent's method is reduced by more than 37%.
- The computing time of the L-BFGS-B method is reduced by more than 33%.

Comparing the calculation times of Computers 2 and 3:

- The computing time of the BFM is reduced by more than 14 %.
- The computing time of the Brent's method is reduced by 17%.
- The computing time of the L-BFGS-B method is reduced by 6%.

Figure 60. shows a scenario of prediction of a future development based on the calculation times of computers 1 and 2 and their age difference.

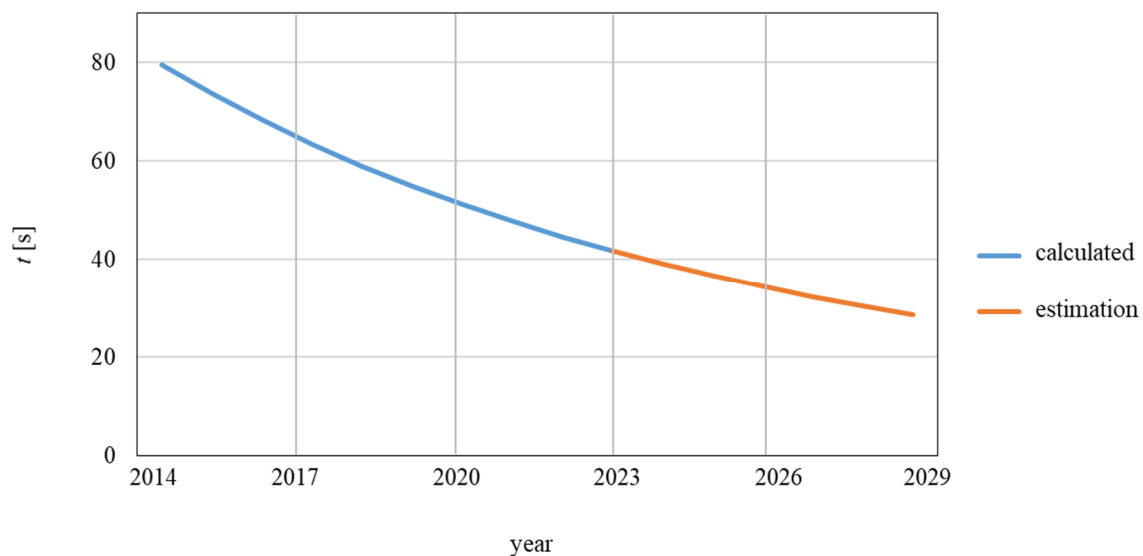

**Figure 60. A projection of BFM calculating speed**

From this analysis, it can be concluded that the BFM is indeed much slower than other methods and that the speed ratio has not changed significantly in the past. When comparing the results of computer 2 (Table 32.), the Brent's method took 21 milliseconds, the L-BFGS-B method completed the task in 11 milliseconds, while the BFM took more than 40 seconds to provide the result.

Despite significant improvements in computation time, the BFM in the given example is still almost 2000 times slower than the Brent's method, the slower of the two chosen control methods.

The projection in Figure 60. shows that the computation time of the BFM for this example will fall below 30 seconds in this decade, but the overall speed will still be much slower than that of the other two methods.

This conservative estimate predicts an improvement in BFM computation speed that will certainly lead to much wider use of the method.

## 7. DISCUSSION

It has already been said that the CMMS begins its life during the construction of the ship, when the system is being prepared. After the delivery of the newbuilding (usually), the CMMS starts to be filled with operational data, i.e. various records entered during the operation of the ship and ship systems. The first maintenance schedule is usually constructed using manufacturers recommendation for the equipment. Manufacturers create their maintenance recommendations based on their interests and logic. Despite extensive testing of the equipment, manufacturers do not know the actual operating conditions of the equipment or the demands that are placed on the equipment. Secondly, manufacturers do not want to be responsible for an increased number of failures caused by long maintenance intervals, especially when they have a financial interest in selling expensive spare parts needed for this maintenance. Based on the above arguments, it is assumed that manufacturers always prepare a "conservative" maintenance schedule, i.e. that their work schedule includes a high degree of safety margin. The second factor that plays a role in the maintenance of the ship is the classification societies, which ensure that ships are well maintained so as not to jeopardize safety (of the ship, cargo, crew and environment). They recommend that maintenance should be carried out according to the manufacturer's recommendations, but they allow the shipowner and crew to modify the maintenance schedule according to the actual requirements of the system, providing that changes either do not affect or improve the safety of the ship. Monitoring the actual requirements of the system requires a proactive approach in controlling the CMMS and utilizing the data collected therein. The title of this thesis was established during the preliminary research when it was found that the data collected in CMMS is generally poorly used or not used at all in maritime companies, and in particular not used for a proactive approach to the maintenance and planning of spare parts for marine mechanical systems.

The usefulness of CMMS data was confirmed in the different phases of the preliminary investigation as well as during this research, showing that the collected data can/should be used as a valuable source for improving maintenance management, spare parts management, work force management and planning and management of spare parts and consumables. Furthermore, part of the preliminary analysis gave a worrying indication that the actual situation in the maritime sector is unfortunately not good when it comes to the actual use of CMMS data. The companies studied only use CMMS because it is mandatory and only use it to meet the requirements and nothing more. Therefore, all the benefits of this system and its data remain

unused, or rather, wasted. These findings, which were obtained during the preliminary research, relate to a relatively small number of analysed companies and their employees. Due to the problem of a small sample, the opinion formed may be wrong and the evidence found could be circumstantial. In addition to inappropriate use of CMMS data, another problem found was questionable knowledge of the CMMS and training of employees using the CMMS, leading to improper and inappropriate use of the system. Again, there is the problem of small sample size and this information may also be incorrect.

This thesis presents an example of using CMMS data on failures to predict the optimal maintenance time as well as to determine the minimum maintenance and spare parts costs. This is linked to the idea of improving (or rather simplify) the MA-CAD method, which is the only method developed to plan and customise technical maintenance systems specifically for ships and the maritime industry. The MA-CAD method uses Weibull analysis to model failures and analyse the system. Although Weibull analysis is widely used and popular, this method is optimal when the system in question is being replaced, but not when it is being repaired. In cases where the system is being repaired, the PLP is the better solution. Since most systems in the maritime industry are repaired and not replaced, the PLP is a good substitute for the Weibull process in the MA-CAD method.

Another important argument is also present in this consideration, namely the complexity of Weibull and PLP parameter estimations. The estimation of the MLEs for Weibull requires a numerical solution, which complicates the estimation. The same problem occurs when the estimation is performed for PLP failure truncated data, but it is not present for PLP with time truncated data. The estimation of the parameters in this case is reduced to less complicated mathematical calculations which is appropriate in the maritime industry, always looking for simpler and cheaper solutions.

The process began with the extraction of data on fuel valve failures for two ships. The data originates from the company's CMMS and is analysed with PLP as described in Section 4.2. Since the data extraction is done on a time truncated basis, the overall estimation of PLP parameters was relatively straightforward. The same failure data is used to estimate the Weibull MLE parameters with a more complex numerical solution. These two data sets are compared using the information criterion to check which model fits the analysed data better. The Akaike Information Criterion was chosen as the method for comparing these data. Due to the sample size, it was replaced by the AICc method, which is the second-order Akaike information criterion. The results of this analysis (in Section 4.3.1) showed that the PLP model had a lower AICc value than the Weibull model, indicating that the PLP model fits the analysed data better.

The application of the PLP method to the failure analysis of previously published data confirmed that the results obtained with the PLP method are similar to those obtained with the Weibull method and that the proposed modification is feasible. Given these two arguments, replacing the Weibull method with the PLP method proved to be a step in the right direction.

A renewed and extended optimization of maintenance and spare parts using the PLP method for failure analysis was also planned as a modification of the MA-CAD method. The optimization determined minimum maintenance costs by varying the major overhaul time and the optimal order quantity of spare parts. The maintenance strategies modelling is performed to mimic the actual conditions recommended by the manufacturer. The continuation of the simple approach is again demonstrated by choosing the BFM to calculate the optimization results, using the raw power of the computer instead of the mathematical knowledge required to solve the optimization equation by another method. The optimization model is programmed in the Python programming language, one of the easiest programming languages to learn and use.

The optimization model for maintenance and spare parts and its results are subjected to a series of checks to verify the accuracy of the process and results. The first check is performed immediately after the completion of the optimization of ship 1 (in Section 5.3.2.). This analysed the behaviour of the model when the degradation factor for the minor overhaul changes. The checks performed showed that the model mimics reality and the optimization results are as expected. When the degradation coefficient  $\alpha = 0$  (i.e. when there is no degradation, i.e. when the minor overhaul is perfect), the time for the major overhaul approaches infinity (when the minor overhaul is perfect, there is no need for the major overhaul). As the degradation coefficient increases, the time for the major overhaul decreases, and at an extremely high coefficient, the time for the minor overhaul becomes the time for the major overhaul.

The second check was the comparison of all optimization results (in Section 5.3.5.) The results for ship 1, ship 2 and for the calculation with estimated parameters for both ships are consistent and clear despite the minor differences observed, confirming that the optimization and its results are in order.

The next check is to analyse the BFM and its results. For this purpose, the optimization equation is solved using two other proven methods. These are the Brent's method and the L-BFGS-B method. The optimization results obtained with these two methods differ from each other and from the BFM to the tenth decimal place or more only in the calculated total cost  $C_{Tot}$  ( $N^*$ ,  $T^*$ ), while the calculated overhaul time  $T^*$  and the optimal order quantity of spare parts  $N^*$  are exactly the same. This confirms that the calculations using the BFM are correct.

The final verification was performed by solving the optimization Equation using failure data modelled with the Weibull method. The comparison of these results with the results of the PLP method showed that the differences in the calculated results are quite small, which is acceptable given the sample size and margin of error.

A renewed and extended optimization model for maintenance and spare parts passed all the checks listed and proved to be a good solution for the intended purpose.

This research has made several contributions. The first contribution is of a purely scientific nature, it represents a modification of the MA-CAD method, i.e. its simplification, which could lead to a wider application of the method, which will be demonstrated in the future. The second contribution is the creation of a renewed and extended optimization method that enables a proactive approach to the maintenance and planning of spare parts for marine mechanical systems. The conclusion from the analysed cases is that the manufacturer's recommended time for major overhaul can be postponed by more than 2000 hours, which corresponds to about 3 months. In addition to reducing the frequency of maintenance and the associated reduction in maintenance and spare parts costs, the results presented show that it is possible to create a more flexible maintenance schedule that allows spare parts to be placed in the most favourable location. The calculation of the order size  $N^*$ , which leads to the lowest total costs for maintenance and spare parts, led neither to significant changes in the order cycle itself nor to significant changes in the order quantities. The resulting optimization result  $N^*$  simply created data-based information about the required order size to be delivered to the ship to ensure smooth maintenance. This information makes it possible to review the planning and control the ordering of spare parts, which can prove to be very important in certain situations.

The third contribution concerns the issue of safety critical spare parts in the inventory policy, which has never been addressed before. This contribution was analysed in depth, revealing that in the shipping industry it is necessary to create another level of stock (or rather a barrier) governed by rules and regulations. This layer not only represents an additional safety factor, but also creates a number of other costs for the company. These additional costs can easily be compensated if these spare parts prevent additional costs (or even damage) caused by the shortage of spare parts. The theoretical approach to this problem is described in Section 2.2.3. while Equations 69 and 70 represent the insertion of the safety critical spare parts into the cost optimization model for maintenance and spare parts. The validity of this insertion is verified in Section 5.4. where the good behaviour of the model is demonstrated again by mimicking a real scenario, this time with respect to safety critical spare parts.



## **7.1. CURRENT AND FUTURE RESEARCH**

In addition to the preliminary research and the main research (which is described in this Chapter), there is also a part that has not yet been completed and is still in progress. Two pieces of research related to this dissertation are running in parallel and are at different stages of completion and will be published in journals as soon as they are finalized.

The first ongoing research work is the proposal for a permanent solution to improve the maintenance plan, which is currently being investigated and will be published in the near future. The idea is to develop a small computer program called DAMIS (the name is coming from Data Analysis and Maintenance Improvement System). The computer program will perform periodic checks of the CMMS database (at regular, predetermined intervals or at the request of the operator) and will search for maintenance reports, especially failures and malfunctions.

After solving the inserted reliability calculations (in this case PLP will be used for failure analysis), the program will present improvement suggestions (based on the preset reliability values), that should be reviewed by the company superintendent. This DSS will be designed to solve the problem of CMMS data monitoring and continuous improvement. Due to the underlying mathematical model and the generic values inserted, it will also simplify the reliability calculations required for maintenance checks. The research work is well advanced and is expected to be published in 2024 or 2025 after the DAMIS has been tested in a real environment.

The second topic under the study, which will also be published in 2024 or 2025 concerns the modification of the current model to optimize engines containing more than one injector per cylinder, i.e. group maintenance policy optimization. For the moment, this research is in the initial phase of the literature research, obtaining failure data and modification of the existing model which is presented in this thesis.

The main problem identified during the preliminary research was the poor quality of the CMMS databases, especially the data on failures. For various reasons, the data was entered poorly, incompletely or not at all. The fact that failure data is incomplete or unavailable in most cases is well known to all those involved in this area and is a major problem that has not been (and probably never will be) solved. As the data in the CMMS is either unavailable or incomplete, this leads to questionable data analysis, especially in the case of a small data sample. Future work should therefore include an analysis of the cost rate function when data is missing, e.g. before a vessel is delivered (no failure data in the CMMS) or when data has only

been partially entered or important information is missing or when one or more entries are missing.

In light of the above, future work should include extensions of this model with new capabilities. The first suggestion, which has already been mentioned, is to extend this model to include the optimization of group maintenance policy. Future extensions of this model should also include cases where data is censored, either left, right, or interval-wise. The last combination should be the optimization of the group maintenance policy with censored data or with missing data.

## 8. CONCLUSION

Maintaining a system is a demanding task that requires considerable human and financial resources. Therefore, it is the goal of every company to set up a well-organised maintenance adapted to the condition of the equipment and the conditions under which the equipment operates. Manufacturers of systems and equipment issue their recommendations for planned maintenance, which in most companies in the maritime industry are the starting point for preparing a planned maintenance system, i.e. a series of actions and tasks scheduled at certain intervals to prevent equipment or system failures. At the same time, company personnel determine the initial quantity of spare parts based on their experience. These two sources form the basis for the creation of the CMMS database. Although the CMMS has all the legally required components at this stage and can therefore function throughout the life of the equipment, it lacks one additional component, namely the adaptation of the system to the actual operating conditions. Once the system is operational, it will very soon collect a considerable amount of data on the use of the plant. The data collected by monitoring the machines in operation is the best source of information about the condition of the equipment and the best source of proactive changes to the system according to real conditions. CMMS records can be used to easily monitor various data, such as failure data over time. Failure data should be regularly retrieved from the system (remotely) and analysed to adjust the maintenance schedule and spare parts quantity to current conditions, i.e. to proactively make changes. A proper analysis of the failure data should be performed using the PLP (as explained in this thesis), which is not only more suitable for repairable systems, but is also mathematically simpler and more user friendly. This analysis is performed in this study using CMMS data from two ships. The results of the analysis of the CMMS data using the PLP method are used for three different purposes, namely to predict the spare parts required for corrective maintenance, to determine the desired maintenance schedule, and to optimise the maintenance and spare parts using a model developed for this purpose. The model is an extended and renewed optimization method for maintenance and spare parts based on the failure analysis performed with the PLP method derived from the old MA-CAD model. The optimization was verified by a sensitivity analysis and then by calculating the data with Weibull, which gave similar results within the statistical error. The BFM used to solve the optimization equation (although BFM and optimization are a contradiction in terms) proved to be a good choice, especially since it was written in Python programming language, which is free for all users (very important in the maritime sector, which

is always looking to reduce costs). The BFM optimization was tested by solving the optimization problem with two other methods, namely the Brent's method and the L-BFGS-B method. The general conclusion of this research is that, based on the analysis shown and the review of the analysed examples, the PLP method is a better choice for failure analysis than the Weibull method and should be used in MA-CAD when the system (component) is repaired (not replaced) after a failure. The optimization model presented makes it possible to determine the most favourable maintenance time that causes the lowest costs and is a supplement to the proactive approach to maintenance and spare parts planning. Presented proposals, applied in the industry will not cause any additional costs but will enable users to obtain reliable information towards proactive changes in the maintenance plan which can save substantial financial amount.

If the proactive approach shown in the two examples in this thesis were applied in practice, the maintenance period could be extended by 15% (as shown in examples) without significantly affecting the safety of the equipment (ship, crew, cargo, environment). Extending the maintenance period reduces the consumption of spare parts and consumables, reduces the workload of the crew and ultimately leads to lower maintenance and spare parts costs. This approach makes it possible to review the planning and control the ordering of spare parts by comparing the actual order with the optimization results, which can be very important in certain situations.

Another aspect of this work that changes the approach to inventory policy in the maritime industry has shown that the introduction of a safety critical minimum stock of spare parts (as required by law and regulation) increases the overall cost of maintenance and spare parts, but at the same time improves the safety of the engineering system by providing an additional safety margin. Furthermore, this financial burden can be easily justified (and compensated for) if even one of the potential financial losses due to missing spare parts is prevented.

## LITERATURE

- [1] Verma, A. K., Ajit, S., Karanki, D. R. (2010). *Reliability and safety engineering*. Vol. 43. pp. 373-392. London: Springer. doi: 10.1007/978-1-84996-232-2
- [2] Arts, J. J. (2013). *Spare parts planning and control for maintenance operations*. PhD Thesis. Industrial Engineering and Innovation Sciences. Technische Universiteit Eindhoven. doi: 10.6100/IR760116
- [3] Driessen, M., Arts, J., van Houtum, G.-J., Rustenburg, W., Huisman, B. (2014). Maintenance spare parts planning and control: a framework for control and agenda for future research. *Production Planning & Control*. pp. 1–20. doi: 10.1080/09537287.2014.907586
- [4] Duffuaa, S. O., Raouf, A. (2015). *Planning and Control of Maintenance Systems*. Second Edition. Springer International Publishing. Switzerland. doi: 10.1007/978-3-319-19803-3
- [5] Stazić, L., Bratić, K., Mihanović, V., Matjašić, J. (2019). *Maintenance process adjustment based on Computerized PMS data*. 1<sup>st</sup> International Conference of Maritime Science & Technology Naše More 2019. Dubrovnik: University of Dubrovnik, Maritime Department. pp. 547-553.
- [6] Davies, C. R. (1990). Computer-based planned maintenance programmes. *Property Management*. Vol. 8(1). pp. 40–60. doi: 10.1108/eum0000000003353
- [7] Parida, A., Kumar, U. (2006). Maintenance performance measurement (MPM): issues and challenges. *Journal of Quality in Maintenance Engineering*. Vol. 12(3). pp. 239–251. doi: 10.1108/13552510610685084
- [8] Bukša, A. (2005). *Modeliranje održavanja broskog porivnog sustava*, doctoral dissertation, Maritime Faculty in Rijeka, Rijeka.
- [9] Vučinić, B. (1994). *MA – CAD, Maintenance Concept Adjustment and Design*, doctoral dissertation. Delft, Faculty of Mechanical Engineering and Marine Technology.
- [10] Waeyenbergh, G., Pintelon, L. (2002). A framework for maintenance concept development. *International Journal of Production Economics*. Vol. 77(3). pp. 299–313. doi: 10.1016/s0925-5273(01)00156-6

- [11] Pintelon, L., Nagarur, N., Van Puyvelde, F. (1999). Case study: RCM – yes, no or maybe? *Journal of Quality in Maintenance Engineering*. Vol. 5(3). pp. 182–192. doi: 10.1108/13552519910282638
- [12] Bukša, A., Šegulja, I., Tomas, V. (2009). Ship Machinery Maintenance Concept Adjustment and Design. *Strojarstvo: časopis za teoriju i praksu u strojarstvu*. Vol. 51(3). pp. 227-238.
- [13] Šegulja, I., Bukša, A. (2006). Ship machinery maintenance. *Pomorstvo*, Vol. 20(2). pp. 105-118.
- [14] Grimmelius, H.T. (2005). *Condition monitoring for marine refrigeration plants based on process models*, doctoral dissertation. Delft, Faculty of Mechanical Engineering and Marine Technology.
- [15] Reijmers, J., Kaminski, M.L., Stapersma, D. (2022). Analytical formulations and comparison of collapse models for risk analysis of axisymmetrically imperfect ring-stiffened cylinders under hydrostatic pressure. *Marine Structures*. Vol. 83. pp. 103161. doi: 10.1016/j.marstruc.2022.103161
- [16] Stazić, L., Knežević, V., Orović, J., Mihanović, L. (2020). Maintenance Interval Adjustment Based on the Experience, Case Study of Marine Air Compressor System. *Naše More: znanstveni časopis za more i pomorstvo*. Vol. 67(2). pp. 146-152. doi: 10.17818/NM/2020/2.7
- [17] Knežević, V., Stazić, L., Orović, J., Pavin, Z. (2022). Optimisation of Reliability and Maintenance Plan of the High-Pressure Fuel Pump System on Marine Engine. *Polish Maritime Research*. Vol. 29(4). pp. 97-104. doi: 10.2478/pomr-2022-0047
- [18] Wagner, S. M., Lindemann, E. (2008). A case study-based analysis of spare parts management in the engineering industry. *Production Planning & Control*. Vol. 19(4). pp. 397–407. doi: 10.1080/09537280802034554
- [19] Zhu, S., Jaarsveld, W. van, Dekker, R. (2019). Spare Parts Inventory Control based on Maintenance Planning. *Reliability Engineering & System Safety*. pp. 106600. doi: 10.1016/j.ress.2019.106600
- [20] Bratić, K., Stazić, L., Mišura, A., Jurić, Z. (2019) *Spare Parts Optimization Using A Planned Maintenance System*. U: Ivošević, Š. & Vidan, P. (ur.), Book of Proceedings, 8<sup>th</sup> International Maritime Science Conference.
- [21] Kovacs, K., Ansari, F., Sihn, W. (2021). A modified Weibull model for service life prediction and spare parts forecast in heat treatment industry. *Procedia Manufacturing*. Vol. 54. pp. 172–177. doi: 10.1016/j.promfg.2021.07.02

- [22] Kontrec, N., Panić, S. (2017). *Spare Parts Forecasting Based on Reliability. System Reliability*. IntechOpen Limited, London, United Kingdom. doi: 10.5772/intechopen.69608
- [23] Patriarca, R., Hu, T., Costantino, F., Di Gravio, G., Tronci, M. (2019). A System-Approach for Recoverable Spare Parts Management Using the Discrete Weibull Distribution. *Sustainability*. Vol. 11(19). pp. 5180. doi: 10.3390/su11195180
- [24] Rigdon, S.E., Basu, A.P. (1989). The power law process: a model for the reliability of repairable systems. *Journal of Quality Technology*. Vol. 21(4). pp.251–260. doi: 10.1080/00224065.1989.11979183
- [25] Vogdrup-Schmidt, L. (2015). *The shipping industry is too conservative and passive. ShippingWatch*. Copenhagen. Denmark. available at: <https://shippingwatch.com/Services/article7817989.ece>. [accessed on February 13<sup>th</sup>, 2022]
- [26] Manuel, M. E. (2012). *Maritime Risk and Organizational Learning*. Ashgate Publishing. pp. 17. doi: 10.1201/9781315593937
- [27] Delorme, M., Iori, M., Mendes, N. F. M. (2021). Solution methods for scheduling problems with sequence-dependent deterioration and maintenance events. *European Journal of Operational Research*, Vol. 295(3). pp. 823–837. doi: 10.1016/j.ejor.2021.03.067
- [28] Qiu, Z., Xia, H. (2021). A novel interval linear programming based on probabilistic dominance. *Fuzzy Sets and Systems*. Vol. 434. pp. 20-47. doi: 10.1016/j.fss.2021.03.006
- [29] Neculai, A. (2022). Sequential Quadratic Programming. *Modern Numerical Nonlinear Optimization*. Springer Optimization and Its Applications. Vol 195. Springer, Cham. doi: 10.1007/978-3-031-08720-2\_15
- [30] Drezner, Z., Kalczynski, P. (2019). Solving nonconvex nonlinear programs with reverse convex constraints by sequential linear programming. *International Transactions in Operational Research*. Vol. 27(3). pp. 1320–1342. doi: 10.1111/itor.12736
- [31] Brent, R. P. (1973). *Algorithms for minimization without derivatives*. Prentice-Hall Inc, New Jersey, USA. ISBN: 0-13-022335-2
- [32] Press, W.H., Teukolsky, S.A., Vetterling, W.T., Flannery, B.P. (2007). *Numerical recipes: The art of scientific computing*, 3<sup>rd</sup> edition. Cambridge university press. New York, USA. ISBN-13: 978-0-511-33555-6

- [33] Lorencin, I., Anđelić, N., Mrzljak, V., Car, Z. (2019). Multilayer Perceptron approach to Condition-Based Maintenance of Marine CODLAG Propulsion System Components. *Pomorstvo*. Vol. 33(2). pp. 181–190. doi: 10.31217/p.33.2.8
- [34] Fei, Y., Rong, G., Wang, B., Wang, W. (2014). Parallel L-BFGS-B algorithm on GPU. *Computers & Graphics*. Vol. 40. pp. 1–9. doi: 10.1016/j.cag.2014.01.002
- [35] Torregrossa, D., Capitanescu, F. (2018). Optimization models to save energy and enlarge the operational life of water pumping systems. *Journal of Cleaner Production*. Vol. 213. pp. 89-98. doi: 10.1016/j.jclepro.2018.12.124
- [36] Frischer, R., Pollak, M., Jančíková, Z. K. (2019). Optimizing logistics routes in the field of maintenance. *Acta logistica*. Vol. 6(3). pp. 93-101. doi: 10.22306/al.v6i3.123
- [37] Xing, Z., Zhang, Z., Guo, J., Qin, Y., Jia, L. (2023). Rail train operation energy-saving optimization based on improved brute-force search. *Applied Energy*. Vol. 330. pp. 120345. doi: 10.1016/j.apenergy.2022.120345
- [38] Shakeri Aski, F., Mirparizi, M., Sheykh Samani, F., Ali Hajabasi, M. (2014). Vibration behavior optimization of planetary gear sets. *Propulsion and Power Research*. Vol. 3(4). pp. 196–206. doi: 10.1016/j.jprr.2014.11.002
- [39] Python (2023). available at: <https://www.python.org/> [accessed on March 5<sup>th</sup>, 2023]
- [40] Ando, T. (2010). *Bayesian Model Selection and Statistical Modeling* (1st ed.). Chapman and Hall/CRC. doi: 10.1201/EBK1439836149
- [41] Neath, A. A., Cavanaugh, J. E. (2011). The Bayesian information criterion: background, derivation, and applications. *Wiley Interdisciplinary Reviews: Computational Statistics*. Vol. 4(2). pp.199–203. doi: 10.1002/wics.199
- [42] Beyers, C. P. (1982). The system engineering analysis: a structured approach for improving ship maintenance. *Naval Engineers Journal*. Vol. 94(2). pp. 118–126. doi: 10.1111/j.1559-3584.1982.tb02433.x
- [43] Revord, L. (1914). The efficient maintenance of turbine machinery. *The Shipbuilder, The Journal of the Shipbuilding, Marine Engineering and Allied Industries*. The Shipbuilder Press, London, UK. Republishing in Journal of the American Society for Naval Engineers. Vol. 26(4). pp. 1378–1384. doi: 10.1111/j.1559-3584.1914.tb00361.x
- [44] Newton, L. V. (1930/1931). Essentials of Motorcoach Maintenance. *SAE Transactions*. Vol. 25/26 (1930/1931). pp. 647-650



- [45] Stallone, S. (1971). *Pan American's Planned Maintenance Control System*. The Space Congress Proceedings 1971 (8th). Vol. 1 Technology Today and Tomorrow, Session 2 - Computer applications. Cocoa Beach, Florida, USA
- [46] Stocking, W. B. (1975). *Ship Maintenance Planning System*. Offshore Technology Conference. doi: 10.4043/2346-ms
- [47] Frankel, E. G. (1982). Ship management systems developments. *Maritime Policy & Management*. Vol. 9(2). pp. 135–143. doi: 10.1080/03088838200000028
- [48] Aydın, Ö. (2017). *Improvement of planned maintenance system onboard ship*. Master's thesis, Piri Reis Üniversitesi, Istanbul, Turkey, available at: <http://openaccess.pirireis.edu.tr/xmlui/bitstream/handle/20.500.12960/61/476650.pdf?sequence=1&isAllowed=y>. [accessed on July 18<sup>th</sup>, 2021].
- [49] Salonen, A., Bengtsson, M., Fridholm, V. (2020). *The possibilities of improving maintenance through CMMS data analysis*. In SPS2020 (pp. 249-260). IOS Press.
- [50] Rastegari, A., Mobin, M. (2016.). *Maintenance decision making, supported by computerized maintenance management system*. In 2016 annual reliability and maintainability symposium (RAMS) (pp. 1-8). IEEE
- [51] Bebić, D., Stazić, L., Komar, I. (2019). Ships shore service optimization using the queueing theory. *International Journal of Simulation Modelling*. Vol. 18(4). pp. 596-607. doi: 10.2507/ijimm18(4)488
- [52] Vukić, L., Stazić, L., Pijaca, M., Peronja, I. (2021). Modelling the optimal delivery of spare parts to vessels: Comparison of three different scenarios. *Cogent Engineering*. Vol. 8(1). pp. 1920565. doi: 10.1080/23311916.2021.1920565
- [53] Hu, Q., Boylan, J. E., Chen, H., Labib, A. (2017). OR in spare parts management: A review. *European Journal of Operational Research*. Vol. 266(2). pp.395–414. doi: 10.1016/j.ejor.2017.07.058
- [54] Dohi, T., Kaio, N., Osaki, S. (1998). On the optimal ordering policies in maintenance theory—survey and applications. *Applied Stochastic Models and Data Analysis*. Vol. 14(4). pp. 309–321. doi: 10.1002/(sici)1099-0747(199812)14:4<309::aid-asm351>3.0.co;2-r
- [55] Arya, V., Sharma, P., Singh, A., De Silva, P. T. M. (2017). An exploratory study on supply chain analytics applied to spare parts supply chain. *Benchmarking: An International Journal*. Vol. 24(6). pp. 1571–1580. doi: 10.1108/bij-04-2016-0053

- [56] Hassan, J., Khan, F., Hasan, M. (2012). A risk-based approach to manage non-repairable spare parts inventory. *Journal of Quality in Maintenance Engineering*. Vol. 18(3). pp. 344–362. doi: 10.1108/13552511211265938
- [57] Liu, B., Esogbue, A. O. (1999). Decision criteria and optimal inventory processes. *Springer Science & Business Media*. ISBN 978-1-4613-7345-2. doi: 10.1007/978-1-4615-5151-5
- [58] Tusar M.I.H., Sarker B.R. (2022). Spare parts control strategies for offshore wind farms: A critical review and comparative study. *Wind Engineering*. Vol. 46(5). pp. 1629-1656. doi: 10.1177/0309524X221095258
- [59] González-Varona, J. M., Poza, D., Acebes, F., Villafañez, F., Pajares, J., López-Paredes, A. (2020). New Business Models for Sustainable Spare Parts Logistics: A Case Study. *Sustainability*. Vol. 12(8). pp. 3071. doi: 10.3390/su12083071
- [60] Ba, K., Dellagi, S., Rezg, N., Erray, W. (2016). Joint optimization of preventive maintenance and spare parts inventory for an optimal production plan with consideration of CO<sub>2</sub> emission. *Reliability Engineering & System Safety*. Vol. 149. pp. 172–186. doi: 10.1016/j.ress.2016.01.006
- [61] Franciosi, C., Lambiase, A., Miranda, S. (2017). Sustainable Maintenance: a Periodic Preventive Maintenance Model with Sustainable Spare Parts Management. *IFAC-PapersOnLine*. Vol. 50(1). pp. 13692–13697. doi: 10.1016/j.ifacol.2017.08.2536
- [62] Mouschoutzi, M., Ponis, S. T. (2022). A comprehensive literature review on spare parts logistics management in the maritime industry. *The Asian Journal of Shipping and Logistics*. doi: 10.1016/j.ajsl.2021.12.003 2092-5212
- [63] Vandeput, N. (2020). *Inventory optimization: Models and simulations*. Walter de Gruyter GmbH & Co KG. Berlin, Germany. ISBN 978-3-11-067391-3. doi: 10.1515/9783110673944
- [64] Trimp, M. E., Sinnema, S. M., Dekker, R., Teunter, R. (2004). Optimise initial spare parts inventories: an analysis and improvement of an electronic decision tool. *Report Econometric Institute EI 2004-52*.
- [65] Axsäter, S. (2015). *Inventory control*, Second edition, Vol. 225. Springer. USA
- [66] Jardine, A. K., Tsang, A. H. (2005). *Maintenance, replacement, and reliability: theory and applications*. CRC press, Boca Raton, USA. ISBN 978-1-4665-5486-3
- [67] Fischer, S., Benzaman, B., Diegel, E., Soriano Gimenez, M., Claudio, D. (2020). Effects of different types of imperfect advance demand information in production systems. *Journal of Simulation*. Vol. 1–13. doi: 10.1080/17477778.2020.1781555

- [68] Boudrika, N. (2018). *Advance demand information in production/inventory systems*. Master recherche conference, ECPMR'15. École Centrale Paris (insu-01764033)
- [69] Nataraja, B. M., Atan, Z. (2019). *Simulation of Allocation Policies for a Serial Inventory System Under Advance Demand Information*. 2019 Winter Simulation Conference (WSC). doi: 10.1109/wsc40007.2019.9004723
- [70] Basten, R. J. I., Ryan, J. K. (2019). The value of maintenance delay flexibility for improved spare parts inventory management. *European Journal of Operational Research*. Vol. 278(2). pp. 646–657. doi: 10.1016/j.ejor.2019.04.023
- [71] Tan, T., Güllü, R., Erkip, N. (2007). Modelling imperfect advance demand information and analysis of optimal inventory policies. *European Journal of Operational Research*. Vol. 177(2). pp. 897–923. doi: 10.1016/j.ejor.2005.12.031
- [72] Lin, X., Basten, R. J. I., Kranenburg, A. A., van Houtum, G. J. (2017). Condition based spare parts supply. *Reliability Engineering & System Safety*. Vol. 168. pp. 240–248. doi: 10.1016/j.ress.2017.05.035
- [73] Ahmadi, T., Atan, Z., de Kok, T., Adan, I. (2019). Optimal control policies for an inventory system with commitment lead time. *Naval Research Logistics (NRL)*. doi: 10.1002/nav.21835
- [74] Chen, F. (2001). Market Segmentation, Advanced Demand Information, and Supply Chain Performance. *Manufacturing & Service Operations Management*. Vol. 3(1). pp. 53–67. doi: 10.1287/msom.3.1.53.9993
- [75] Topan, E., Tan, T., van Houtum, G.-J., Dekker, R. (2017). Using imperfect advance demand information in lost-sales inventory systems with the option of returning inventory. *IISE Transactions*. Vol. 50(3). pp. 246–264. doi: 10.1080/24725854.2017.1403060
- [76] Cavalieri, S., Garetti, M., Macchi, M., Pinto, R. (2008). A decision-making framework for managing maintenance spare parts. *Production Planning & Control*. Vol. 19(4). pp. 379–396. doi: 10.1080/09537280802034471
- [77] Antosz, K., Ratnayake, R. M. C. (2019). Spare parts' criticality assessment and prioritization for enhancing manufacturing systems' availability and reliability. *Journal of Manufacturing Systems*. Vol. 50. pp. 212–225. doi: 10.1016/j.jmsy.2019.01.003
- [78] Gajpal, P. P., Ganesh, L. S., Rajendran, C. (1994). Criticality analysis of spare parts using the analytic hierarchy process. *International Journal of Production Economics*. Vol 35(1-3). pp. 293–297. doi: 10.1016/0925-5273(94)90095-7

- [79] Van Volkenburg, C., Montgomery, N., Banjevic, D., Jardine, A. (2014). *The effect of deterioration on spare parts holding*. 2014 Reliability and Maintainability Symposium. doi: 10.1109/rams.2014.6798445
- [80] Diaz, A., Fu, M. C. (1997). Models for multi-echelon repairable item inventory systems with limited repair capacity. *European Journal of Operational Research*. Vol. 97(3). pp. 480-492. doi: 10.1016/S0377-2217(96)00279-2
- [81] Zhang, M., Ye, H., Wang, D., Pan, E. (2021). Joint Optimization of Condition-Based Maintenance and Spare Parts Orders for Multi-Unit Systems with Dual Sourcing. *Reliability Engineering & System Safety*. Vol. 210, pp. 107512. doi: 10.1016/j.ress.2021.107512
- [82] Dekker, R. (1996). Applications of maintenance optimization models: a review and analysis. *Reliability Engineering & System Safety*. Vol. 51(3). pp. 229–240. doi: 10.1016/0951-8320(95)00076-3
- [83] Goshorn, J. A., Deegan, E. M., Layton, B. E. (2010). Spare Part Storage Optimization Onboard Deployable Military Support Assets. *Naval Engineers Journal*. Vol. 122(1). pp. 137–147. doi:10.1111/j.1559-3584.2009.00234.x
- [84] Pahl, J. (2022). *Maritime Spare Parts Management: Current State-of-the-Art*. In Proceedings of the 55th Hawaii International Conference on System Sciences. pp. 1676-1685. doi: 10.24251/HICSS.2022.207
- [85] Louit, D., Pascual, R., Banjevic, D., Jardine, A. K. S. (2011). Optimization models for critical spare parts inventories—a reliability approach. *Journal of the Operational Research Society*. Vol. 62(6). pp. 992–1004. doi: 10.1057/jors.2010.49
- [86] Godoy, D. R., Pascual, R., Knights, P. (2013). Critical spare parts ordering decisions using conditional reliability and stochastic lead time. *Reliability Engineering & System Safety*. Vol. 119. pp. 199–206. doi: 10.1016/j.ress.2013.05.026
- [87] Nakagawa, T. (1986). Periodic and sequential preventive maintenance policies. *Journal of Applied Probability*. Vol. 23(02). pp. 536–542. doi: 10.2307/3214197
- [88] Nakagawa, T. (2008). *Advanced reliability models and maintenance policies*. Springer Science & Business Media. London, UK. ISBN 978-1-84800-293-7. doi: 10.1007/978-1-84800-294-4
- [89] Nakagawa, T. (2005). *Maintenance Theory of Reliability*. Springer, London. ISBN 978-1-85233-939-5. doi: 10.1007/1-84628-221-7

- [90] Zhao, X., Al-Khalifa, K. N., Magid Hamouda, A., Nakagawa, T. (2017). Age replacement models: A summary with new perspectives and methods. *Reliability Engineering & System Safety*. Vol. 161. pp. 95–105. doi: 10.1016/j.ress.2017.01.011
- [91] Lim, J. H., Qu, J., Zuo, M. J. (2016). Age replacement policy based on imperfect repair with random probability. *Reliability Engineering & System Safety*. Vol. 149. pp. 24–33. doi: 10.1016/j.ress.2015.10.020
- [92] Brezavšček, A., Hudoklin, A. (2003). Joint optimization of block-replacement and periodic-review spare-provisioning policy. *IEEE Transactions on Reliability*. Vol. 52(1). pp. 112–117. doi: 10.1109/tr.2002.805790.
- [93] Yang, R., Kang, J. (2017). A joint optimal policy of block preventive replacement and spare part inventory. *International Journal of System Assurance Engineering and Management*. Vol. 8(4). pp. 740-746. doi: 10.1007/s13198-017-0593-9
- [94] Nguyen, D. Q., Brammer, C., Bagajewicz, M. (2008). New Tool for the Evaluation of the Scheduling of Preventive Maintenance for Chemical Process Plants. *Industrial & Engineering Chemistry Research*. Vol. 47(6). pp. 1910–1924. doi: 10.1021/ie071231i
- [95] Park, M., Pham, H. (2012). A Generalized Block Replacement Policy for a k-Out-of-n System With Respect to Threshold Number of Failed Components and Risk Costs. *IEEE Transactions on Systems, Man, and Cybernetics - Part A: Systems and Humans*. Vol. 42(2). pp. 453–463. doi: 10.1109/tsmca.2011.2162499
- [96] Olde Keizer, M. C. A., Teunter, R. H., Veldman, J. (2017). Joint condition-based maintenance and inventory optimization for systems with multiple components. *European Journal of Operational Research*. Vol. 257(1). pp. 209–222. doi: 10.1016/j.ejor.2016.07.047
- [97] Yang, L., Ye, Z., Lee, C.-G., Yang, S., Peng, R. (2018). A two-phase preventive maintenance policy considering imperfect repair and postponed replacement. *European Journal of Operational Research*. doi: 10.1016/j.ejor.2018.10.049
- [98] Wang, W. (2012). A stochastic model for joint spare parts inventory and planned maintenance optimisation. *European Journal of Operational Research*. Vol. 216(1). pp. 127–139. doi: 10.1016/j.ejor.2011.07.031
- [99] De Jonge, B., Scarf, P. A. (2019). A review on maintenance optimization. *European Journal of Operational Research*. Vol. 285(3). pp. 805-824. doi: 10.1016/j.ejor.2019.09.047

- [100] Hu, J., Sun, Q., Ye, Z.-S. (2020). Condition-Based Maintenance Planning for Systems Subject to Dependent Soft and Hard Failures. *IEEE Transactions on Reliability*. Vol. 70.4. pp. 1468-1480 pp, 1–13. doi: 10.1109/tr.2020.2981136
- [101] Ren, Z., Verma, A. S., Li, Y., Teuwen, J. J. E., Jiang, Z. (2021). Offshore wind turbine operations and maintenance: A state-of-the-art review. *Renewable and Sustainable Energy Reviews*. Vol. 144. pp. 110886. doi: 10.1016/j.rser.2021.110886
- [102] Galar, D., Sandborn, P., Kumar, U. (2017). *Maintenance Costs and Life Cycle Cost Analysis* (1st ed.). CRC Press. Boca Raton, United States of America. doi: 10.1201/9781315154183.
- [103] Shafiee, M., Sørensen, J. D. (2017). Maintenance optimization and inspection planning of wind energy assets: Models, methods and strategies. *Reliability Engineering & System Safety*. doi: 10.1016/j.ress.2017.10.025
- [104] Wang, Y., Liu, Y., Chen, J., Li, X. (2020). Reliability and condition-based maintenance modeling for systems operating under performance-based contracting. *Computers & Industrial Engineering*. pp. 106344. doi: 10.1016/j.cie.2020.106344
- [105] Van Horenbeek, A., Scarf, P. A., Cavalcante, C. A. V., Pintelon, L. (2013). The Effect of Maintenance Quality on Spare Parts Inventory for a Fleet of Assets. *IEEE Transactions on Reliability*. Vol. 62(3). pp. 596–607. doi: 10.1109/tr.2013.2270409
- [106] Chelbi, A., Aït-Kadi, D. (2001). Spare provisioning strategy for preventively replaced systems subjected to random failure. *International Journal of Production Economics*. Vol. 74(1-3). pp. 183–189. doi: 10.1016/s0925-5273(01)00125-6
- [107] Chelbi, A., Ait-Kadi, D. (2004). Analysis of a production/inventory system with randomly failing production unit submitted to regular preventive maintenance. *European Journal of Operational Research*. Vol. 156(3). pp. 712–718. doi: 10.1016/s0377-2217(03)00254-6
- [108] Pham, H., Wang, H. (1996). Imperfect maintenance. *European Journal of Operational Research*. Vol. 94(3). pp. 425–438. doi: 10.1016/s0377-2217(96)00099-9
- [109] Zheng, M., Ye, H., Wang, D., Pan, E. (2021). Joint Optimization of Condition-Based Maintenance and Spare Parts Orders for Multi-Unit Systems with Dual Sourcing. *Reliability Engineering & System Safety*. Vol. 210. pp. 107512. doi: 10.1016/j.ress.2021.107512
- [110] Zhang, A., Srivastav, H., Barros, A., Liu, Y. (2020). Study of testing and maintenance strategies for redundant final elements in SIS with imperfect detection

- of degraded state. *Reliability Engineering & System Safety*. pp. 1073-93. doi: 10.1016/j.ress.2020.107393
- [111] Su, C., Liu, Y. (2019). Multi-objective imperfect preventive maintenance optimisation with NSGA-II. *International Journal of Production Research*. pp. 1–17. doi: 10.1080/00207543.2019.1641237
- [112] Cheaitou, A., Cariou, P. (2017). A two-stage maritime supply chain optimisation model. *International Journal of Shipping and Transport Logistics*. Vol. 9(2). pp. 202. doi: 10.1504/ijstl.2017.082525
- [113] Kian, R., Bektaş, T., Ouelhadj, D. (2018). Optimal spare parts management for vessel maintenance scheduling. *Annals of Operations Research*. Vol. 272. pp. 323–353. doi: 10.1007/s10479-018-2907-y
- [114] Eruguz, A. S., Tan, T., van Houtum, G.J. (2017). Integrated maintenance and spare part optimization for moving assets. *IIEE Transactions*. Vol. 50(3). pp. 230–245. doi: 10.1080/24725854.2017.1312037
- [115] Ikbāl, N. A. M., Halim, S. A., Ali, N. (2022). Estimating Weibull Parameters Using Maximum Likelihood Estimation and Ordinary Least Squares: Simulation Study and Application on Meteorological Data. *Mathematics and Statistics*. Vol. 10. pp. 269-292. doi: 10.13189/ms.2022.100201
- [116] Rockette, H., Antle, C., Klimko, L. A. (1974). Maximum Likelihood Estimation with the Weibull Model. *Journal of the American Statistical Association*. Vol. 69(345). pp. 246–249. doi: 10.1080/01621459.1974.10480164
- [117] Abernethy, R. B., Breneman, J. E., Medlin, C. H., Reinman, G. L. (1983). *Weibull analysis handbook*. Pratt & Whitney Aircraft. West Palm Beach, US.
- [118] Duane, J. T. (1964). Learning curve approach to reliability monitoring. *IEEE transactions on Aerospace*. Vol. 2(2). pp. 563-566.
- [119] Crow, L. H. (1975). *Reliability analysis for complex, repairable systems*. Technical report No.138. Army Materiel Systems Analysis Activity. Aberdeen Proving Ground Md.
- [120] Crow, L. H. (1993). *Confidence intervals on the reliability of repairable systems*. In Annual Reliability and Maintainability Symposium 1993 Proceedings. pp. 126-134. IEEE
- [121] Crow, L. H. (1982). Confidence interval procedures for the Weibull process with applications to reliability growth. *Technometrics*. Vol. 24(1). pp. 67-72. doi: 10.1080/00401706.1982.10487711

- [122] Crow, L. H. (1990). *Evaluating the reliability of repairable systems*. Annual Proceedings on Reliability and Maintainability Symposium. doi: 10.1109/arms.1990.67969.
- [123] Kumar, U., Klefsjö, B. (1992). Reliability analysis of hydraulic systems of LHD machines using the power law process model. *Reliability Engineering & System Safety*. Vol. 35(3). pp. 217–224. doi: 10.1016/0951-8320(92)90080-5
- [124] Qarahasanlou, A. N., Barabadi, A., Ataei, M., Einian, V. (2017). Spare part requirement prediction under different maintenance strategies. *International Journal of Mining, Reclamation and Environment*. pp. 1–14. doi: 10.1080/17480930.2017.1373883.
- [125] Soman, R., Boyer, A., Kim, J.M., Peters, K. (2022) Particle Swarm Optimization Algorithm for Guided Waves Based Damage Localization Using Fiber Bragg Grating Sensors in Remote Configuration. *Sensors*. Vol. 22(16). pp. 6000. doi: 10.3390/s22166000
- [126] Vincent, P., Cunha Sergio, G., Jang, J., Kang, I.M., Park, J., Kim, H., Lee, M., Bae, J. H. (2020). Application of Genetic Algorithm for More Efficient Multi-Layer Thickness Optimization in Solar Cells. *Energies*. Vol. 13. pp. 1726. doi: 10.3390/en13071726
- [127] Liang, Y. D. (2013). *Introduction to programming using Python*. Pearson Education, Inc. PNew Jersey, USA. ISBN 13: 978-0-13-274718-9
- [128] Nagpal, A., Gabrani, G. (2019). *Python for Data Analytics, Scientific and Technical Applications*. Amity International Conference on Artificial Intelligence (AICAI), Dubai. pp. 140-145. doi: 10.1109/AICAI.2019.8701341.
- [129] Frontoni, E., Rosetti, R., Paolanti, M. Alves, A. (2019). HATS project for lean and smart global logistic: a shipping company case study. *Manufacturing Letters*. doi: 10.1016/j.mfglet.2019.12.003
- [130] Gutierrez, M., Rivera, F. A. (2021). Undershoot and order quantity probability distributions in periodic review, reorder point, order-up-to-level inventory systems with continuous demand. *Applied Mathematical Modelling*. Vol. 91. pp. 791–814. doi: 10.1016/j.apm.2020.09.014
- [131] Tongdan, J. (2018). *Reliability Engineering and Services*. John Wiley & Sons, Inc. Hoboken, USA. ISBN 9781119167013
- [132] Oil Companies International Marine Forum. (2018). *Safety Critical Equipment and Spare Parts Guidance*. London, United Kingdom.



- [133] Lloyds Register. (2011). *Guidance Information on Spare Gear*. London, United Kingdom.
- [134] International Maritime Organization (IMO). (2010). *The International Safety Management (ISM) Code*. available at: <https://www.imo.org/en/OurWork/HumanElement/Pages/ISMCode.aspx>. [accessed on March 22<sup>nd</sup> 2022].
- [135] IACS. (2006). *List of minimum recommended spare parts for main internal combustion engines of ships for unrestricted service*. IACS Rec.26 1990/Rev.1. available at: <https://iacs.org.uk/publications/recommendations/21-40/> [accessed on February 16<sup>th</sup> 2020].
- [136] Weibull, W. (1939). A Statistical theory of the strength of materials. Ingeniörs Vetenskaps Akademiens Handligar Report No. 151, Stockholm
- [137] Rinne, H. (2008). *The Weibull distribution: a handbook*. CRC press, Taylor & Francis Group. Boca Raton, USA. ISBN 978-1-4200-8743-7
- [138] Chen, D., Chen, Z. (2009). Statistical inference about the location parameter of the three-parameter Weibull distribution. *Journal of Statistical Computation and Simulation*. Vol. 79(3). pp. 215–225. doi: 10.1080/00949650701413565
- [139] Shaban, A. H., Resen, A. K., Bassil, N. (2019). Weibull parameters evaluation by different methods for windmills farms. *Energy Reports*. Vol. 6. pp. 188-199. doi: 10.1016/j.egy.2019.10.037
- [140] Kang, S., Khanjari, A., You, S., Lee, J. H. (2021). Comparison of different statistical methods used to estimate Weibull parameters for wind speed contribution in nearby an offshore site, Republic of Korea. *Energy Reports*. Vol. 7, pp. 7358-7373. doi: 10.1016/j.egy.2021.10.078
- [141] Griggs, J. A., Zhang, Y. (2003). Determining the confidence intervals of Weibull parameters estimated using a more precise probability estimator. *Journal of Materials Science Letters*. Vol. 22(24). pp. 1771 – 1773. doi: 10.1023/b:jmsl.0000005417.39465.35
- [142] Nelson, W. B. (2005). *Applied life data analysis*. John Wiley & Sons, Inc. Hoboken, USA. ISBN 0-471-09458-7
- [143] Mann, N. R., Fertig, K. W. (1973). Tables for Obtaining Weibull Confidence Bounds and Tolerance Bounds Based on Best Linear Invariant Estimates of Parameters of the Extreme-Value Distribution. *Technometrics*. Vol. 15(1). pp. 87. doi: 10.2307/1266827

- [144] Bain, L. J., Engelhardt, M. (1981). Simple approximate distributional results for confidence and tolerance limits for the Weibull distribution based on maximum likelihood estimators. *Technometrics*. Vol. 23(1). pp. 15-20. doi: 10.1080/00401706.1981.10486231
- [145] Lawless, J. F. (1978). Confidence Interval Estimation for the Weibull and Extreme Value Distributions. *Technometrics*. Vol. 20(4). pp. 355. doi: 10.2307/1267633
- [146] Thoman, D. R., Bain, L. J., Antler, C. E. (1970). Maximum Likelihood Estimation, Exact Confidence Intervals for Reliability, and Tolerance Limits in the Weibull Distribution. *Technometrics*. Vol. 12(2). pp. 363–371. doi: 10.1080/00401706.1970.1048867
- [147] Zapata, C. J., Torres, A., Kirschen, D. S., Rios, M. A. (2009). *Some common misconceptions about the modeling of repairable components*. In 2009 IEEE Power & Energy Society General Meeting. pp. 1-8. IEEE. doi: 10.1109/pes.2009.5275819
- [148] Mazzola, M., Merlo, A., Aggogeri, F. (2008). *Analysis of machine tool failures using advanced reliability models for complex repairable systems*. In ASME International Mechanical Engineering Congress and Exposition. Vol. 48777. pp. 163-171.
- [149] Chen, Z. (2004). Bayesian and empirical Bayes approaches to power law process and microarray analysis. Doctoral dissertation. University of South Florida.
- [150] Guida, M., Calabria, R., Pulcini, G. (1989). Bayes inference for a non-homogeneous Poisson process with power intensity law (reliability). *IEEE Transactions on Reliability*. Vol. 38(5). pp. 603-609.
- [151] Jacobs, J. A. (2021). *Failure prediction of critical mine machinery* (Doctoral dissertation. North-West University (South Africa)).
- [152] Muralidharan, K. (2018). Repairable System Modeling Using Power Law Process. System Reliability Management, Solutions and Technologies. CRC Press. Boca Raton, USA. pp. 79-101. doi: 10.1201/9781351117661-6
- [153] Muralidharan, K., Shah, R., Dhandhukia, D. H. (2008). Future reliability estimation based on predictive distribution in power law process. *Quality Technology & Quantitative Management*. Vol. 5(3). pp. 193-201. doi: 10.1080/16843703.2008.11673396
- [154] Bain, L. J., Engelhardt, M. (1980). Inferences on the Parameters and Current System Reliability for a Time Truncated Weibull Process. *Technometrics*. Vol. 22(3). pp. 421–426. doi:10.1080/00401706.1980.10486174

- [155] Finkelstein, J. M. (1976). Confidence bounds on the parameters of the Weibull process. *Technometrics*. Vol. 18(1). pp.115-117.
- [156] Nelson, W. (2000). Weibull prediction of a future number of failures. *Quality and Reliability Engineering International*. Vol. 16(1). pp. 23–26. doi: 10.1002/(sici)1099-1638(200001/02)16:1<23::aid-qre283>3.0.co;2-q
- [157] Tang, Z., Zhou, W., Zhao, J., Wang, D., Zhang, L., Liu, H., Yang, Y., Zhou, C. (2015). Comparison of the Weibull and the Crow-AMSAA Model in Prediction of Early Cable Joint Failures. *IEEE Transactions on Power Delivery*. Vol. 30(6). pp. 2410–2418. doi: 10.1109/tpwr.2015.2404926
- [158] Nordman, D. J., Meeker, W. Q. (2002). Weibull Prediction Intervals for a Future Number of Failures. *Technometrics*. Vol. 44(1). pp. 15–23. doi: 10.1198/004017002753398191
- [159] Deloux, E., Castanier, B., Bérenguer, C. (2009). Predictive maintenance policy for a gradually deteriorating system subject to stress. *Reliability Engineering & System Safety*. Vol. 94(2). pp. 418–431. doi: 10.1016/j.res.2008.04.002
- [160] Hoseinie, S. H., Ataei, M., Khalokakaie, R., Ghodrati, B., Kumar, U. (2012). Reliability analysis of the cable system of drum shearer using the power law process model. *International Journal of Mining, Reclamation and Environment*. Vol. 26(4). pp. 309–323. doi: 10.1080/17480930.2011.622477
- [161] MAN B&W Diesel A/S. (2010). *Instructions for Main Engines*. MAN B&W Diesel A/S.
- [162] Carlo, F. D., Arleo, M. A. (2017). *Imperfect Maintenance Models, from Theory to Practice*. System Reliability. doi: 10.5772/intechopen.69286
- [163] Zhang, F., Jardine, A. K. S. (1998). Optimal maintenance models with minimal repair, periodic overhaul and complete renewal. *IIE Transactions*. Vol. 30(12). pp. 1109–1119. doi: 10.1023/a:1007572016758
- [164] Márquez, A. C. (2007). *The maintenance management framework: models and methods for complex systems maintenance*. Springer Science & Business Media. London, UK. ISBN-13: 9781846288203
- [165] Ben-Daya, M., Kumar, U., Murthy, D. P. (2016). *Introduction to maintenance engineering: modelling, optimization and management*. John Wiley & Sons, Inc. Hoboken, USA. ISBN 9781118487198

- [166] Finkelstein, M. (2008). *Failure rate modelling for reliability and risk*. Springer Science & Business Media, London, United Kingdom. ISBN 978-1-84800-985-1. doi: 0.1007978-1-84800-986-8
- [167] Ahmadi, A., Soleimanmeigouni, I., Block, J., Letot, C. (2016). Optimum failure management strategy for periodically inspected units with imperfect maintenance. *IFAC-PapersOnLine*. Vol. 49(12). pp. 799–804. doi: 10.1016/j.ifacol.2016.07.872
- [168] Malik, M. A. K. (1979). Reliable Preventive Maintenance Scheduling. *A IIE Transactions*. Vol. 11(3). pp. 221–228. doi: 10.1080/05695557908974463
- [169] Chan, P. K. W., Downs, T. (1978). Two criteria for preventive maintenance. *IEEE Transactions on Reliability*. Vol. 27(4). pp. 272-273. doi: 10.1109/TR.1978.5220367
- [170] Nakagawa, T. (1979). Optimum Policies When Preventive Maintenance is Imperfect. *IEEE Transactions on Reliability*. Vol. R-28(4). pp. 331–332. doi: 10.1109/tr.1979.5220624
- [171] Nakagawa, T. (1979). Imperfect Preventive-Maintenance. *IEEE Transactions on Reliability*. Vol. R-28(5). pp. 402–402. doi: 10.1109/tr.1979.5220657
- [172] Block, H. W., Borges, W. S., Savits, T. H. (1985). Age-dependent minimal repair. *Journal of Applied Probability*. Vol. 22(02). pp. 370–385. doi:10.2307/3213780
- [173] Kijima, M., Morimura, H., Suzuki, Y. (1988). Periodical replacement problem without assuming minimal repair. *European Journal of Operational Research*. Vol. 37(2). pp. 194–203. doi: 10.1016/0377-2217(88)90329-3
- [174] Bhattacharjee, M. C. (1987). New results for the Brown-Proschan model of imperfect repair. *Journal of Statistical Planning and Inference*. Vol. 16. pp. 305–316. doi: 10.1016/0378-3758(87)90083-8
- [175] Yeh, L. (1988). A note on the optimal replacement problem. *Advances in Applied Probability*. Vol.20/2. pp. 479 – 482. doi: 10.2307/1427402
- [176] Wang, H., Pham, H. (1996). Optimal maintenance policies for several imperfect repair models. *International Journal of Systems Science*. Vol. 27(6). pp. 543-551. doi: 10.1080/00207729608929248
- [177] Wang, H., Pham. H. (1996). Optimal age-dependent preventive maintenance policies with imperfect maintenance. *International Journal of Reliability, Quality and Safety Engineering*. Vol. 03(02). pp. 119–135. doi: 10.1142/s0218539396000090
- [178] Wang, H., Pham, H. (1996). A quasi renewal process and its applications in imperfect maintenance. *International Journal of Systems Science*. Vol. 27(10). pp. 1055–1062. doi: 10.1080/00207729608929311

- [179] Shaked, M., Shanthikumar, J. G. (1986). Multivariate Imperfect Repair. *Operations Research*. Vol. 34(3). pp. 437–448. doi: 10.1287/opre.34.3.437
- [180] Lin, D. Y., Wei, L. J. (1989). The Robust Inference for the Cox Proportional Hazards Model. *Journal of the American Statistical Association*. Vol. 84(408). pp. 1074–1078. doi: 10.1080/01621459.1989.1047887
- [181] Nakagawa, T. (1988). Sequential imperfect preventive maintenance policies. *IEEE Transactions on Reliability*. Vol. 37(3). pp. 295–298. doi: 10.1109/24.3758
- [182] Usher, J. S., Kamal, A. H., Syed, W. H. (1998). Cost optimal preventive maintenance and replacement scheduling. *IIE Transactions*. Vol. 30(12). pp. 1121–1128. doi: 10.1080/07408179808966568
- [183] Gertsbakh, I. (2000). *Reliability theory: with applications to preventive maintenance*. Springer Series in Reliability Engineering, London, United Kingdom.
- [184] Kobbacy, K. A., Murthy, D. P. (2008). *Complex system maintenance handbook*. Springer Series in Reliability Engineering, London, United Kingdom. pp. 417-436. doi: 10.1007/978-1-84800-011-7
- [185] Ghodrati, B., Banjevic, D., Jardine, A. K. S. (2010). *Developing effective spare parts estimations results in improved system availability*. 2010 Proceedings - Annual Reliability and Maintainability Symposium (RAMS), San Jose, California, USA. pp. 1-6. doi: 10.1109/RAMS.2010.5447985.
- [186] Merriam-Webster Inc. (2023). Brute-force. available at: <https://www.merriam-webster.com/dictionary/brute-force#:~:text=adjective,planned%2C%20or%20precisely%20directed%20methods.>, [accessed on August 2<sup>nd</sup>, 2023]
- [187] Andrade-Cabrera, C., O’Dwyer, C., Finn, D. P. (2020). Integrated Cost-Optimal Residential Envelope Retrofit Decision-Making and Power Systems Optimisation using Ensemble Models. *Energy and Buildings*. Vol. 109833. doi: 10.1016/j.enbuild.2020.109833
- [188] Lin, L., Wang, F., Luo, B. (2019). An optimization algorithm inspired by propagation of yeast for fleet maintenance decision making problem involving fatigue structures. *Applied Soft Computing*. Vol. 85. pp. 105755. doi: 10.1016/j.asoc.2019.105755
- [189] Möller, M., Vuik, C. (2017). On the impact of quantum computing technology on future developments in high-performance scientific computing. *Ethics and Information Technology*. Vol. 19(4). pp. 253–269. doi: 10.1007/s10676-017-9438-0
- [190] SciPy (2023). available at: <https://scipy.org/>. [accessed on March 1<sup>st</sup>, 2023]

- [191] Rigdon, S. E., Basu, A. P. (1990). Estimating the intensity function of a power law process at the current time: time truncated case. *Communications in Statistics - Simulation and Computation*. Vol. 19(3). pp. 1079–1104. doi: 10.1080/03610919008812906
- [192] Rigdon, S. E., Ma, X., Bodden, K. M. (1998). Statistical Inference for Repairable Systems Using the Power Law Process. *Journal of Quality Technology*. Vol. 30(4). pp. 395–400. doi: 10.1080/00224065.1998.11979875.
- [193] Konishi, S., Kitagawa, G. (2008). *Information Criteria and Statistical Modeling*. Springer Series in Statistics. doi: 10.1007/978-0-387-71887-3
- [194] Hurvich, C. M., Tsai, C.L. (1989). Regression and time series model selection in small samples. *Biometrika*. Vol. 76(2). pp. 297–307. doi: 10.1093/biomet/76.2.297
- [195] Burnham, K., Anderson, D. (2004). *Model selection and multi-model inference*. Second. NY: Springer-Verlag. ISBN 0-387-95364-7.
- [196] Banks, J., Reichard, K., Drake, M. (2008). *System reliability and condition based maintenance*. 2008 Annual Reliability and Maintainability Symposium. doi: 10.1109/rams.2008.4925833
- [197] Loucks, D. P., van Beek, E. (2017). *Water Resource Systems Planning and Management*. Springer International Publishing AG. Cham, Switzerland. ISBN 978-3-319-44232-7 doi: 10.1007/978-3-319-44234-1
- [198] Letot, C., Dehombreux, P., Rivière-Lorphèvre, E., Fleurquin, G., Lesage, A. (2015). A degradation model for maintenance improvement in respect of cost and availability. *Journal of Quality in Maintenance Engineering*. Vol. 21(1). pp. 55–69. doi: 10.1108/jqme-01-2013-0001
- [199] Coit, D. W., Evans, J. L., Vogt, N. T., Thompson, J. R. (2005). A Method for Correlating Field Life Degradation with Reliability Prediction for Electronic Modules. *Quality and Reliability Engineering International*. Vol. 21(7). pp. 715–726. doi: 10.1002/qre.710
- [200] Stage, S. A. (2013). Comments on an improvement to the Brent's method. *International Journal of Experimental Algorithms*. Vol. 4(1). pp. 1-16.
- [201] Zhu, C., Byrd, R. H., Lu, P., Nocedal, J. (1997). Algorithm 778: L-BFGS-B: Fortran subroutines for large-scale bound-constrained optimization. *ACM Transactions on mathematical software (TOMS)*. Vol. 23(4). pp. 550-560. doi: 10.1145/279232.279236

- [202] Schaller, R. R. (1997). Moore's law: past, present and future. *IEEE Spectrum*. Vol. 34(6). pp. 52–59. doi: 10.1109/6.591665

## LIST OF FIGURES AND DIAGRAMS

Figure 1. CMMS areas for improvement .....	12
Figure 2. The analysis of the work reports (feedback).....	13
Figure 3. Decision-making steps [76] .....	15
Figure 4. The continuous review inventory policy [63, 65] .....	21
Figure 5. The periodic review inventory policy [63, 65].....	22
Figure 6. Fixed period inventory policy with safety stocks [63].....	23
Figure 7. Recent example of fixed period inventory policy with safety stocks [130].....	24
Figure 8. Inventory policy with spare parts shortage in land based industry [131].....	25
Figure 9. Inventory policy with spare parts shortage in maritime industry [8] .....	26
Figure 10. Fixed period inventory policy in the maritime industry.....	27
Figure 11. Influence of parameter $\beta_w$ on Weibull PDF (based on [138]).....	30
Figure 12. Influence of parameter $\beta_w$ on Weibull failure rate (based on [138]).....	32
Figure 13. Influence of parameter $\eta$ on Weibull PDF (based on [138]).....	32
Figure 14. Sample size effect on $\beta_w$ [141].....	36
Figure 15. Duane claim (based on [118]).....	38
Figure 16. Influence of parameter $\beta_{PLP}$ on PLP PDF with constant $\theta$ .....	40
Figure 17. Influence of parameter $\beta_{PLP}$ on PLP PDF with constant $\lambda_{PLP}$ .....	40
Figure 18. Influence of parameter $\theta$ on PLP PDF with constant $\beta_{PLP}$ .....	41
Figure 19. MAN B&W fuel injector [161].....	48
Figure 20. Minimal repair after failure.....	51
Figure 21. Perfect maintenance at 16000 hours of operation.....	52
Figure 22. Maintenance model at the beginning of the research.....	53
Figure 23. The influence of the maintenance types on mean number of failures.....	55
Figure 24. The influence of the maintenance types on reliability .....	56
Figure 25. Imperfect maintenance.....	57
Figure 26. Function intensity in the model.....	58
Figure 27. Calculation of $N_{CM}$ for ship 1 .....	64
Figure 28. Excerpt from the Figure 27. ....	65
Figure 29. Brute force flow diagram .....	70
Figure 30. Failure data for ship 1 .....	80
Figure 31. Failure data for ship 2 .....	81
Figure 32. Reliability comparison of ship 1 .....	83
Figure 33. Reliability comparison of ship 2 .....	85
Figure 34. Reliability comparison.....	87



Figure 35. Cost rate function for ship 1.....	99
Figure 36. Costs per unit time for various $N$ for ship 1.....	99
Figure 37. Cost rate function for ship 1 with $\alpha = 0.05$ .....	100
Figure 38. Cost rate function for ship 1 with $\alpha = 0.15$ .....	101
Figure 39. Cost rate function for ship 1 at $CI_{LL} = (0.6131, 88714.9077)$ .....	102
Figure 40. Cost rate function for ship 1 at $CI_{UL} = (2.0534, 3847.7371)$ .....	103
Figure 41. Cost rate function for ship 2.....	104
Figure 42. Costs per unit time for various $N$ for ship 2.....	104
Figure 43. Cost rate function for both ships.....	105
Figure 44. Costs per unit time for various $N$ for both ships.....	106
Figure 45. Cost rate function for ship 1 without $S_{CS}$ .....	108
Figure 46. Cost rate function for ship 1 without $S_{CS}$ and with $C_{SS} = 843$ [€].....	109
Figure 47. Cost rate function for ship 2 without $S_{CS}$ .....	110
Figure 48. Cost rate function for ship 2 without $S_{CS}$ and with $C_{SS} = 876$ [€].....	111
Figure 49. Cost rate function time for both ships without $S_{CS}$ .....	112
Figure 50. Cost rate function for ship 1 calculated using Weibull method.....	114
Figure 51. Costs for various $N$ for ship 1 calculated using Weibull.....	114
Figure 52. Cost rate function for ship 2 calculated using Weibull method.....	115
Figure 53. Costs for various $N$ for ship 2 calculated using Weibull.....	115
Figure 54. Optimization results of ship 1 using three methods.....	118
Figure 55. Optimization results of ship 2 using three methods.....	118
Figure 56. Optimization results of Both ships using three methods.....	118
Figure 57. Speed of different optimization methods on computer 1.....	119
Figure 58. Speed of different optimization methods on computer 2.....	120
Figure 59. Speed of different optimization methods on computer 3.....	120
Figure 60. A projection of BFM calculating speed.....	121

## LIST OF TABLES

Table 1. Commonly used confidence levels [117] .....	35
Table 2. Fuel valves maintenance plan.....	49
Table 3. Exhaust valves failure data [8] .....	73
Table 4. Exhaust valves Weibull parameters [8].....	74
Table 5. Exhaust valves PLP parameters .....	75
Table 6. Fuel injectors Weibull parameters [8] .....	75
Table 7. Fuel injectors failure data [8] .....	76
Table 8. Fuel injectors PLP parameters.....	77
Table 9. Fuel pumps Weibull parameters [8] .....	77
Table 10. Fuel pumps failure data [8] .....	78
Table 11. Fuel pumps PLP parameters.....	78
Table 12. Comparison of parameters.....	78
Table 13. Failure data, ship 1 .....	80
Table 14. Failure data, ship 2 .....	81
Table 15. PLP parameter estimation results.....	86
Table 16. AIC <sub>c</sub> of Weibull method for ship 1 .....	89
Table 17. AIC <sub>c</sub> of PLP method for ship 1 .....	89
Table 18. AIC <sub>c</sub> of Weibull method for ship 2 .....	89
Table 19. AIC <sub>c</sub> of PLP method for ship 2 .....	90
Table 20. AIC <sub>c</sub> final results .....	90
Table 21. AIC and AIC <sub>c</sub> test of MA-CAD failure data .....	91
Table 22. Confidence interval estimators range .....	91
Table 23. Optimal PM time for different reliability .....	96
Table 24. Values of constants in the optimization.....	98
Table 25. Changes in the optimization results with changes in $\alpha$ .....	101
Table 26. Comparison of optimization results .....	106
Table 27. Spare parts shortage costs analysis for ship 1 .....	109
Table 28. Spare parts shortage costs analysis for ship 2 .....	111
Table 29. PLP and Weibull optimization results comparison .....	116
Table 30. Comparison of BFM, Brent's and L-BFGS-B results .....	118
Table 31. Computer specifications .....	119
Table 32. Comparison of computational times.....	120

## LIST OF ABBREVIATIONS

ABBREV.	SHORT OF	MEANING
ABAO	As Bad As Old	Type of maintenance action, returning the unit to a condition before the failure, also called minimal repair.
ADI	Advanced Demand Information	Information about future requirements for the certain product or service gathered from the analysis of the previous periods.
AGAN	As Good As New	Type of maintenance action, after failure repairing the unit to a condition as good as new, also called perfect repair.
AIC	Akaike information criterion	An estimator of relative quality of statistical models for a given set of data.
AICc	a second-order AIC	A modification of Akaike information criterion to be used on smaller samples.
AMSAA	Army Materiel Systems Analysis Activity	An organization for analysing all aspects of weapons system performance, characteristics and behaviour in the US Army.
BFM	Brute Force Method	A straightforward method of solving a problem that rely on sheer computing power, calculating all solutions of the problem and choosing the best
BIC	Bayesian information criterion	An estimator of relative quality of statistical models for a given set of data.
CDF	Cumulative Distribution Function	The probability of equipment failure over time.
CEO	Chief Executive Officer	The highest-ranking person in a company.
CM	Corrective Maintenance	A maintenance activity that is performed after the failure.
CMMS	Computerized Maintenance Management System	An computerized information system was created to use for maintenance, a system developed around PMS, containing more modules.
DNV-GL	Det Norske Veritas & Germanischer Lloyd	The former name of an international classification society, today known as DNV.
DAMIS	Data Analysis and Maintenance	Proposed title of future DSS
DSS	Decision Support System	A computer program and its data which help with analysis and facilitate decision making.
ELCF	Expected Life Cycle Frequency	Expected number of preventive and corrective actions during the lifetime of the component.
ELFF	Expected Life Failure Frequency	A measure describing the probability that reserve equipment will fail during repair of the working machine.
ELPF	Expected Life Prevention Frequency	Expected number of preventive actions during the lifetime of the component.
EOQ	Economic Order Quantity	The ideal quantity of spares to purchase in order to meet demand and obtain minimal costs.
ERP	Enterprise resource planning	A type of software used to manage all business activities.
FMA	Failure Mode Analysis	A method for analysing a process to identify where and how it might fail.
FMCC	Failure Mode – Cause Combination	A method used to identify and reduce risks.

GIC	Generalised Information Criteria	An estimator of relative quality of statistical models for a given set of data.
GPU	Graphics Processing Unit	A electronic circuit designed to accelerate computer graphics and image processing.
L-BFGS-B	Limited memory Broyden–Fletcher–Goldfarb–Shanno	An iterative optimization algorithm in the family of quasi-Newton methods for solving nonlinear optimization problems.
LCC	Life Cycle Costs	All the costs that will be created during the lifespan of the equipment.
LL	Log likelihood	A measure of goodness of fit for any model.
MA-CAD	Maintenance Concept Adjustment and Design	A method developed for the design and adaptation of technical maintenance systems for ships and the maritime industry.
MLE	Maximum Likelihood Estimation	A method of estimating the parameters of an assumed probability distribution, given some observed data.
MRO	Maintenance, Repair, Operations	Name used for all maintenance activities in various shore industries.
MTBF	Mean Time Between Failures	The average time between system breakdowns
NHPP	Non-Homogeneous Poisson Process	A parametric model used to represent events with a non-constant failure recurrence rate.
PDF	Probability Density Function	An integral of the density of the variable density over a given range.
PLP	Power Law Process	An infinite NHPP model frequently used to present the reliability of repairable systems based on the analysis of observed failure data.
PM	Planned Maintenance	A maintenance activity that is planned, documented, and scheduled.
PMS	Planned Maintenance System	A system that serves to plan and document maintenance following various requirements.
PvM	Preventive Maintenance	A maintenance activity that is performed to prevent the failure
RAM	Random Access Memory	A form of electronic computer memory that can be read and changed in any order.
RI	Risk Index	The result of a risk evaluation.
SLP	Sequential Linear Programming	An optimization technique used for solving nonlinear optimization problems.
SQP	Sequential Quadratic Programming	An iterative technique for solving nonlinear optimization problems.
SMS	Safety Management System	A set of established policies, practices and procedures in the company that ensure the safety of ship, cargo, crew and environment.
VED	Vital, Essential, and Desirable	An analysis that prioritizes items based on critical service values.

## LIST OF VARIABLES

SYMBOL	DESCRIPTION	UNIT
$\alpha$	Degradation coefficient	
$\beta_{PLP}$	PLP shape parameter	
$\hat{\beta}_{PLP}^{FT}$	MLE of PLP shape parameter, estimated according to failure truncation	
$\hat{\beta}_{PLP}^{TT}$	MLE of PLP shape parameter, estimated according to time truncation	
$\beta_w$	Weibull shape parameter	
$\eta$	Weibull scale parameter	
$\hat{\theta}$	PLP scale parameter	
$\hat{\theta}^{FT}$	MLE of PLP scale parameter, estimated according to failure truncation	
$\hat{\theta}^{TT}$	MLE of PLP scale parameter, estimated according to time truncation	
$\mu$	Weibull location parameter	
$v_k$	The value of the shortfall of the order	
$\Pi_1$	Lower confidence limit estimator	
$\Pi_2$	Upper confidence limit estimator	
$\sigma_d$	Demand deviation	
$\omega$	Approximation factor	
$C_{CM}$	Costs of corrective maintenance	[€/h]
$C_{CMC}$	Cost of consumables for a corrective maintenance	[€/h]
$C_{CME}$	External costs of corrective maintenance (damage to ship and cargo, persons, environment, etc.)	[€/h]
$C_{CMI}$	Indirect internal costs of corrective maintenance (stoppage costs, failure costs, costs of damage to other equipment, etc.)	[€/h]
$C_{CMW}$	Work force costs of corrective action	[€/h]
$C_{cus}$	Customs, agent, paperwork fee, and other costs (most of these costs are fixed costs, regardless of the parcel size)	[€]
$C_{Del}$	Spare parts delivery costs	[€]
$C_{Dam}$	Costs of damage to other equipment	[€]
$C_{Fai}$	Component failure costs	[€]
$C_{Han}$	Spare parts transport, handling, ... (most of these costs depend on the parcel size)	[€]
$C_{Hol}$	Holding costs (storage costs + degradation costs)	[€]
$CI$	Confidence interval	
$CI_{LL}$	Lower confidence limit	
$CI_{UL}$	Upper confidence limit	
$C_M$	Maintenance costs	[€/h]
$C_{MH}$	Work force hourly costs	[€]
$C_{PMi}$	Costs of minor overhaul (imperfect maintenance)	[€/h]
$C_{PMiC}$	Cost of consumables for a minor, imperfect overhaul	[€/h]
$C_{PMiI}$	The indirect internal costs of a minor, imperfect overhaul (stoppage, etc.),	[€/h]

$C_{PMiW}$	Work force costs of a minor, imperfect overhaul	[€/h]
$C_{PMp}$	Costs of a main overhaul (perfect maintenance)	[€/h]
$C_{PMpC}$	Cost of consumables for a major overhaul	[€/h]
$C_{PMpl}$	The indirect internal costs of a major overhaul (stoppage, etc.)	[€/h]
$C_{PMpW}$	Work force costs for a major, perfect overhaul	[€/h]
$C_{Pur}$	Spare parts purchase costs	[€]
$C_S$	Spare parts costs	[€/h]
$C_{Spa}$	Costs of unit sizes of spare parts	[€]
$C_{SS}$	Spare parts shortage costs	[€/h]
$C_{Stp}$	Stoppage hourly costs	[€]
$C_{Str}$	Spare parts storage costs	[€]
$C_{Tot}(N^*, T^*)$	Total costs of the maintenance and spare parts	[€/h]
$e^a$	Degradation factor	
$h_{CM}$	Number of hours needed to perform corrective action	
$h_{PMi}$	Number of hours needed to perform a minor overhaul	
$h_{PMp}$	Number of hours needed to perform a major overhaul	
$H(t)$	Number of failures in analysed period	
$H^W(t)$	Number of failures in analysed period calculated using Weibull method	
$H^{PLP}(t)$	Number of failures in analysed period calculated using PLP method	
$K$	The number of periods	
$k$	Number of systems	
$L$	The likelihood function	
$L_K$	The lead time of the order	
$n$	Number of failures	
$n_q$	Number of failures	
$N^*$	Optimum order quantity that minimize the total maintenance and spare parts cost	
$N_{CM}(t)$	Number of spare parts required for corrective maintenance in period $t$	
$N_i$	The inventory level	
$N_i^{mar}$	The inventory level in the maritime industry	
$N_{PM}(t)$	Number of spare parts required for preventive maintenance in period $t$	
$N_{PMi}$	The quantity of spare parts required for the imperfect minor overhaul	
$N_{PMp}$	The quantity of spare parts required for the major overhaul	
$N_m$	Number of spares needed in period $n$	
$N(T, t_R)$	Total number of spare parts in a period $t_R$	
$N_T$	Total number of spare parts for the order period	
$N_u$	Number of units (components)	
$p$	The number of estimated parameters	
$p_c$	Factor for dividing $S_{CS}$ costs to multiple periods; ( $0 < p_c < 1$ ).	
$P_{PMi}$	Probability that the stoppage costs for a minor overhaul will be incurred	

$P_{PMp}$	Probability that the stoppage costs for a major overhaul will be incurred	
$Q_K$	The order quantity for period $K$	
$R$	The order period	[h]
$R_D$	Desired reliability	
$s$	Truncation parameter	
$S_{CS}$	Safety critical spare parts minimum	
$S_M$	Stock (spare parts) level maximum	
$S_S$	Stock (Spare parts) safety minimum quantity	
$T$	Planned maintenance period	[h]
$T^*$	Optimum preventive maintenance time that minimize the total maintenance and spare parts cost	[h]
$t$	time	[h]
$t_n$	Time of the last failure	[h]
$t_R$	The order period	[h]
$u(t)$	PLP intensity function	
$\hat{u}(t)$	MLE if the PLP intensity function	
$W$	Number of persons performing the task	
$z_\alpha$	Service level factor	
$z_{\alpha/2}$	the upper $\alpha/2$ point of the standard normal distribution	

## **BIOGRAPHY**

Ladislav Stazić was born on October 12, 1966 in Dubrovnik into a family with a long association with the sea and work at sea. After completing elementary school, he graduated from the maritime school in Split, majoring in marine engineering. Immediately after graduating, he joined his first ship as an apprentice in marine engineering department. After a year of training, he passed the exam and was licensed as Marine Engineer Officer in 1986. He continued his education at the Faculty of Maritime Studies in Dubrovnik, studies in Split and graduated Marine Engineering High school in 1990. He attended the Faculty of Maritime Studies in Split, where he majored in marine engineering (mag. ing. nav. mech.).

In his professional career, he sailed on various types of ships as Marine Engineer Officer and later as Marine Chief Engineer (from 1998). He ended his active sea service in 2007 when he became an instructor for various CMMS programs and technical consultant for a company specialized in computer programs in the maritime industry. In 2013, he was one of the founders of an independent small business in this field.

In 2017, he moved to University of Split, Faculty of Maritime Studies, where he works as an assistant for the subjects Maintenance Management, Maintenance and Reliability of Mechanical Systems of Ships, Work on Simulator and Sailing Practice I and Work on Simulator and Sailing Practice II. In addition, he worked in the Faculty's training centre and in the Faculty's adult education program.

In the academic year 2017/2018, he continued his education in Postgraduate Scientific Doctoral Studies at the University of Rijeka, Faculty of Maritime Studies. In 2019, he moved to the Postgraduate Doctoral University Study "Technologies in Maritime Affairs" at the University of Split, Faculty of Maritime Studies.

His main research interests include CMMS and its various aspects and applications, maintenance management, spare parts management, as well as some interest in the study of air pollutant emissions in shipping.



**Papers published in journals:**

1. **Stazić, L.**, Račić, N., Stanivuk, T., Dobrota, Đ. (2023). Determination of Benefits of the Application of CMMS Database Improvement Proposals / *Applied sciences* (Basel), Vol. 13 (2023), no. 4; pp. 2731, 13. doi: 10.3390/app13042731
2. Stanivuk, T., Vidović, F., **Stazić, L.**, Damjanić, D. (2022). Kreiranje sustava održavanja pogonskih motora broda, primjer iz prakse / *Journal of the Polytechnic of Rijeka*, Vol. 10 (2022), no. 1; pp. 439-450. doi: 10.31784/zvr.10.1.24
3. Domić, I., Stanivuk, T., **Stazić, L.**, Pavlović, I. (2022). Analysis of LNG carrier propulsion developments / *Journal of applied engineering science*, Vol 20, No.4; pp. 1122-1132. doi: 10.5937/jaes0-36809
4. Knežević, V., **Stazić, L.**, Orović, J., Pavin, Z. (2022). Optimisation of Reliability and Maintenance Plan of the High-Pressure Fuel Pump System on Marine Engine / *Polish Maritime Research*, Vol. 29 , no. 4; pp. 97-104. doi: 10.2478/pomr-2022-0047
5. **Stazić, L.**, Bratić, K., Stanivuk, T., Vidović, F. (2022) Student Advancement During Simulator Training / *Časopis Pomorskog fakulteta Kotor*, Ivošević, Špiro (ur.). Kotor: Faculty of Maritime Studies Kotor, University of Montenegro, pp. 44-51. doi: 10.56080/jms221104
6. Bratić, K., **Stazić, L.**, Vukičević, M., Lalić, B. (2021). Cruise Vessels Air Pollution Inventory for the Port of Kotor / *Transactions on maritime science*, Vol. 10, no 1. doi: 10.7225/toms.v10.n01.016
7. Vukić, L., **Stazić, L.**, Pijaca, M., Peronja, I. (2021). Modelling the optimal delivery of spare parts to vessels: Comparison of three different scenarios / *Cogent engineering*, Vol. 8, no. 1; pp. 1-19. doi: 10.1080/23311916.2021.1920565
8. Vulić, N., Bratić, K., Lalić, B., **Stazić, L.** (2021). Implementing Simulation X in the modelling of marine shafting steady state torsional vibrations / *Polish Maritime Research*, Vol. 28; pp. 63-71. doi: 10.2478/pomr-2021-0022
9. Stanivuk, T., **Stazić, L.**, Batinović, J., Batinović, A. (2021). Impact of Sars-Cov-2 virus on Maritime Traffic in the Port of Ploce / *European transport/trasporti europei*, Vol. 82; no. 7, pp. 13. doi: 10.48295/ET.2021.82.7
10. Perić, T., **Stazić, L.**, Bratić, K. (2021). Potential Benefits Of Electrically Driven Ferry, Case Study / *Pedagogika* (Sofia), Vol. 2021-7S, pp. 217-224. doi: 10.53656/ped21-7s.19pot

11. Mihanović, L., Lalić, B., Bratić, K., **Stazić, L.** (2021). Distribution of the International Marine Traffic Air Pollutant Emissions in the Port of Split / *TransNav*, Vol. 15, no. 3; pp. 611-614. doi: 10.12716/1001.15.03.15
12. Račić, N., Lalić, B., Komar, I., Vidović, F., **Stazić, L.** (2021). Air Pollutant Emission Measurement / *Pedagogika (Sofia)*, Vol. 2021 - 6S, pp. 132-140. doi: 10.53656/ped21-6s.11air
13. Vulić, N., Bratić, K., Lalić, B., **Stazić, L.** (2021). Propeller Load Modelling In The Calculations Of Marine Shafting Torsional Vibrations / *Pedagogika (Sofia)*, vol. 93 no. 6s; pp. 204-216. doi: 10.53656/ped21-6s.18pro
14. Stanivuk, T., **Stazić, L.**, Vidović, F., Bratić, K. (2021). Assessment of the Concept of the New Methodology for the Evaluation of Ship Planned Maintenance System / *TransNav*, Vol. 15, no. 4; pp. 739-742. doi: 10.12716/1001.15.04.03
15. Stanivuk, T., Mišura, A., **Stazić, L.**, Štolfa, I. (2021). Determination of the Cruise Vessels Seasonal Pattern in Eastern Adriatic / *TransNav*, Vol. 15, no. 4; pp. 743-748. doi: 10.12716/1001.15.04.04
16. Stanivuk, T., Mahić, J., **Stazić, L.**, Perdić-Lukačević, H. (2021). LNG market and fleet analysis / *Transport problems = Problemy transportu*, Vol. 16, no. 4; pp. 173-183. doi: 10.21307/tp-2021-069
17. **Stazić, L.**, Knežević, V., Orović, J., Mihanović, L. (2020). Maintenance Interval Adjustment Based on the Experience, Case Study of Marine Air Compressor System / *Naše more : znanstveni časopis za more i pomorstvo*, Vol. 67, no. 2; pp. 146-152. doi: 10.17818/NM/2020/2.7
18. **Stazić, L.**, Bratić, K., Dobrota, Đ., Lalić, B. (2020). Revisions of the SMS maintenance procedures based on computerized PMS data / *Scientific Bulletin of Naval Academy*, Vol. 23, no. 1, pp. 166-170. doi: 10.21279/1454-864X-20-11-021
19. **Stazić, L.**, Radonja, R., Pelić, V., Lalić, B. (2020). The Port of Split international marine traffic emissions inventory / *Pomorstvo: scientific journal of maritime research*, Vol. 34, no. 1; pp. 32-39. doi: 10.31217/p.34.1.4
20. Stanivuk, T., **Stazić, L.**, Vidović, F., Čobanov, A. (2020). Ship Planned Maintenance System Data Analysis / *IJTTE. International Journal for Traffic and Transport Engineering*, Vol 4, pp. 432-436. doi: 10.7708/ijtte.2020.10(4).02
21. Knežević, V., Orović, J., **Stazić, L.**, Čulin, J. (2020). Fault Tree Analysis and Failure Diagnosis of Marine Diesel Engine Turbocharger System / *Journal of marine science and engineering, Special Issue*, Vol. 8, pp. 1004. doi: 10.3390/jmse8121004

22. **Stazić, L.**, Stanivuk, T., Mihanović, V. (2019). Testing of the Evaluation Methodology for Ship's Planned Maintenance System / Journal of applied engineering science, Vol. 17, no. 3; pp. 273-279. doi: 10.5937/jaes17-22652
23. Bratić, K., Pavić, I., Vukša, S., **Stazić, L.** (2019). Review of Autonomous and Remotely Controlled Ships in Maritime Sector / Transactions on maritime science, Vol. 8, no. 2; pp. 253-265. doi. 10.7225/toms.v08.n02.011
24. Bebić, D., **Stazić, L.**, Komar I. (2019). Ships shore service optimization using the queueing theory / International journal of simulation modelling, Vol. 18, no. 4, pp. 596-607. doi: 10.2507/IJSIMM18(4)488
25. **Stazić, L.**, Komar, I., Mihanović, L., Mišura, A. (2018). Shipowner's Impact on Planned Maintenance System Database Quality Grades Resemblance Equalization / Transactions on maritime science, Vol. 7, no. 1; pp. 5-22. doi: 10.7225/toms.v07.n01.001
26. Bebić, D., **Stazić, L.**, Mišura, A., Komar, I. (2018). EDD – economic benefit analysis of extending dry docking interval / Transactions on maritime science, Vol. 7, no. 2; pp. 164-173. doi: 10.7225/toms.v07.n02.006
27. **Stazić, L.**, Komar, I., Račić, N. (2017). Evaluation Methodology for Ship's Planned Maintenance System Database / Transactions on maritime science, Vol. 6, no. 2; pp. 109-116. doi: 10.7225/toms.v06.n02.002

**Papers published in conference proceedings:**

1. **Stazić, L.**, Lalić, B., Bartulović, D. (2023). Ship components identification systems, 3<sup>rd</sup> International Conference of Maritime Science & Technology, Our Sea 2023, Dubrovnik, Croatia / Mišković, Darijo, Hasanspahić, Nermin, (ed), Maritime Department, University of Dubrovnik
2. **Stazić, L.**, Pavlović, I., Stanivuk, T., Bratić, K. (2022). Replacement of 2D simulator training with shorter 3D simulator training / 20<sup>th</sup> International Conference on Transport Science, ICTS 2022, Portoroz, Slovenia, Maritime, transport and logistics science, conference proceedings / Zanne, Marina; Bajec, Patricija; Twrdy, Elen (ed.). Portorož: Fakulteta za pomorstvo in promet Univerza v Ljubljani, 2022. pp. 337-343.
3. Čalić, A., **Stazić, L.**, Pavlović, I. (2022). Improvement of Student's Engine Room knowledge and operational skills during Simulator training / Proceedings TIE 2022, Čačak, Serbia, 9<sup>th</sup> International scientific conference Technics and Informatics in Education / Milićević, Ivan (ed.). Kragujevac: Fakultet tehničkih nauka Univerziteta u Novom Sadu. pp. 116-120. doi: 10.46793/TIE22.116C
4. Stanivuk, T., Galić, S., **Stazić, L.** (2021). The navigation in ancient times and the mathematics / 2<sup>nd</sup> International Conference of Maritime Science & Technology, Naše more 2021, Conference proceedings / Mišković, Darijo ; Hasanspahić, Nermin (ed). Maritime Department, University of Dubrovnik
5. **Stazić, L.**, Knežević, V., Račić, N., Orović, J. (2021). Fault Tree Analysis as a replacement for manufacturers maintenance instructions / 2<sup>nd</sup> International Conference of Maritime Science & Technology, Naše more 2021, Conference proceedings / Mišković, Darijo ; Hasanspahić, Nermin (ed). Maritime Department, University of Dubrovnik
6. Stanivuk, T., Mišura, A., **Stazić, L.**, Galić, S. (2020). Analysis of inspections in LNG shipping company / Maritime, Transport and Logistics Science: Conference Proceedings / Marina Zanne, Patricija Bajec, Elen Twrdy - Portorož, Slovenia: Faculty of Maritime Studies and Transport / Zanne, Marina, Bajec, Patricija, Twrdy, Elen (ed.). Portorož: Fakulteta za pomorstvo in promet Univerza v Ljubljani, pp. 320-325. (izvorni znanstveni rad)
7. Bratić, K., Vidović, F., **Stazić, L.** (2020). Use of Merlin System and Recorded Instructions in Engine Room Simulator Training / Proceedings TIE 2020. 8<sup>th</sup>

International Scientific Conference Technics and Informatics in Education / Milićević, Ivan (ur.). Čačak: Fakultet tehničkih nauka Univerziteta u Novom Sadu, pp. 282-285.

8. Knežević, V., **Stazić, L.**, Orović, J., Mihanović, L. (2019). Use of PMS Continuous Improvement Scheme for Maintenance Adjustments in Shipping Industry / Book of abstracts (International Maritime Science Conference), Ivošević, Špiro, Vidan, Pero (ed.). Kotor: CIP - Nacionalna biblioteka Crne Gore, pp. 415-420.
9. Mišura, A., **Stazić, L.**, Stanivuk, T., Komar, I. (2019). Verification of the Evaluation methodology for ship's Planned Maintenance System database / Book of abstracts (International Maritime Science Conference), Ivošević, Špiro, Vidan, Pero (ed.). Kotor: CIP - Nacionalna biblioteka Crne Gore, pp. 441-445.
10. Bratić, K., **Stazić, L.**, Mišura, A., Jurić, Z. (2019). Spare Parts Optimization Using A Planned Maintenance System / Book of abstracts (International Maritime Science Conference), Ivošević, Špiro, Vidan, Pero (ed.). Kotor: CIP - Nacionalna biblioteka Crne Gore, pp. 389-395.
11. **Stazić, L.**, Bratić, K., Mihanović, V., Matjašić, J. (2019). Maintenance process adjustment based on Computerized PMS data / 1<sup>st</sup> International Conference of Maritime Science & Technology, Naše More 2019 / Koboević, Žarko ; Mišković, Darijo (ed.). Dubrovnik: Pomorski odjel Sveučilišta u Dubrovniku, pp. 547-553.
12. **Stazić, L.**, Komar, I., Mišura, A., Bukljaš Skočibušić, M. (2018). Simplification of evaluation methodology for ship's PMS database / Maritime, Transport and Logistics Science: Conference Proceedings / Marina Zanne, Patricija Bajec, Pero Vidan, Maja Krčum (ed.). Portorož: Fakulteta za pomorstvo in promet Univerza v Ljubljani, pp. 346-350.